

# H3C WX3800H Series Access Controllers

## Installation Guide

New H3C Technologies Co., Ltd.  
<http://www.h3c.com>

Document version: 6W101-20190520

**Copyright © 2018-2019, New H3C Technologies Co., Ltd. and its licensors**

**All rights reserved**

No part of this manual may be reproduced or transmitted in any form or by any means without prior written consent of New H3C Technologies Co., Ltd.

**Trademarks**

Except for the trademarks of New H3C Technologies Co., Ltd., any trademarks that may be mentioned in this document are the property of their respective owners.

**Notice**

The information in this document is subject to change without notice. All contents in this document, including statements, information, and recommendations, are believed to be accurate, but they are presented without warranty of any kind, express or implied. H3C shall not be liable for technical or editorial errors or omissions contained herein.

**Environmental protection**

This product has been designed to comply with the environmental protection requirements. The storage, use, and disposal of this product must meet the applicable national laws and regulations.

# Preface

This installation guide describes the procedures for installing, accessing, troubleshooting, and maintaining the WX3800H access controllers.

This preface includes the following topics about the documentation:

- [Audience](#)
- [Conventions](#)
- [Documentation feedback](#)

## Audience

This documentation is intended for:

- Network planners.
- Field technical support and servicing engineers.
- Network administrators working with the WX3800H access controllers.

## Conventions

The following information describes the conventions used in the documentation.





### Command conventions

Convention	Description
<b>Boldface</b>	<b>Bold</b> text represents commands and keywords that you enter literally as shown.
<i>Italic</i>	<i>Italic</i> text represents arguments that you replace with actual values.
[ ]	Square brackets enclose syntax choices (keywords or arguments) that are optional.
{ x   y   ... }	Braces enclose a set of required syntax choices separated by vertical bars, from which you select one.
[ x   y   ... ]	Square brackets enclose a set of optional syntax choices separated by vertical bars, from which you select one or none.
{ x   y   ... } *	Asterisk marked braces enclose a set of required syntax choices separated by vertical bars, from which you select a minimum of one.
[ x   y   ... ] *	Asterisk marked square brackets enclose optional syntax choices separated by vertical bars, from which you select one choice, multiple choices, or none.
&<1-n>	The argument or keyword and argument combination before the ampersand (&) sign can be entered 1 to n times.
#	A line that starts with a pound (#) sign is comments.













### GUI conventions

Convention	Description
<b>Boldface</b>	Window names, button names, field names, and menu items are in Boldface. For example, the <b>New User</b> window opens; click <b>OK</b> .
>	Multi-level menus are separated by angle brackets. For example, <b>File &gt; Create &gt; Folder</b> .

## Symbols

Convention	Description
 <b>WARNING!</b>	An alert that calls attention to important information that if not understood or followed can result in personal injury.
 <b>CAUTION:</b>	An alert that calls attention to important information that if not understood or followed can result in data loss, data corruption, or damage to hardware or software.
 <b>IMPORTANT:</b>	An alert that calls attention to essential information.
<b>NOTE:</b>	An alert that contains additional or supplementary information.
 <b>TIP:</b>	An alert that provides helpful information.

## Network topology icons

Convention	Description
	Represents a generic network device, such as a router, switch, or firewall.
	Represents a routing-capable device, such as a router or Layer 3 switch.
	Represents a generic switch, such as a Layer 2 or Layer 3 switch, or a router that supports Layer 2 forwarding and other Layer 2 features.
	Represents an access controller, a unified wired-WLAN module, or the access controller engine on a unified wired-WLAN switch.
	Represents an access point.
	Represents a wireless terminator unit.
	Represents a wireless terminator.
	Represents a mesh access point.
	Represents omnidirectional signals.
	Represents directional signals.
	Represents a security product, such as a firewall, UTM, multiservice security gateway, or load balancing device.
	Represents a security module, such as a firewall, load balancing, NetStream, SSL VPN, IPS, or ACG module.

## Examples provided in this document

Examples in this document might use devices that differ from your device in hardware model, configuration, or software version. It is normal that the port numbers, sample output, screenshots, and other information in the examples differ from what you have on your device.

# Documentation feedback

You can e-mail your comments about product documentation to [info@h3c.com](mailto:info@h3c.com).

We appreciate your comments.

# Contents

Preparing for installation .....	1
Safety recommendations .....	1
Safety symbols .....	1
General safety recommendations .....	1
Electrical safety .....	1
Laser safety .....	2
Examining the installation site .....	2
Temperature and humidity .....	2
Cleanliness .....	2
Cooling .....	3
ESD prevention .....	3
EMI .....	4
Lightning protection .....	5
Installation accessories .....	5
Installation tools .....	5
Pre-installation checklist .....	6

# Preparing for installation

H3C WX3800H series access controllers include the following models:

- WX3820H
- WX3840H

## Safety recommendations

To avoid any equipment damage or bodily injury, read the following safety recommendations before installation. Note that the recommendations do not cover every possible hazardous condition.

### Safety symbols

When reading this document, note the following symbols:

**⚠ WARNING** means an alert that calls attention to important information that if not understood or followed can result in personal injury.

**⚠ CAUTION** means an alert that calls attention to important information that if not understood or followed can result in data loss, data corruption, or damage to hardware or software.

### General safety recommendations

- Make sure the installation site is flat, vibration-free, and away from electromagnetic interferences. Make sure ESD and anti-slip measures are in place.
- Do not place the device on an unstable case or desk. The device might be severely damaged in case of a fall.
- Keep the chassis and installation tools away from walk areas.
- Keep the chassis clean and dust-free.
- Do not place the device near water or in a damp environment. Prevent water or moisture from entering the device chassis.
- Ensure good ventilation of the equipment room and keep the air inlet and outlet vents of the device free of obstruction.
- Make sure the operating voltage is in the required range.
- Use a screwdriver to fasten screws.
- After you move the device from a location below 0°C (32°F) to the equipment room, follow these guidelines to prevent condensation:
  - Wait a minimum of 30 minutes before unpacking the device.
  - Wait a minimum of 2 hours before powering on the device.

### Electrical safety

- Carefully examine your work area for possible hazards, such as moist floors, ungrounded power extension cables, or missing safety grounds.
- Locate the emergency power-off switch in the room before installation. Shut off the power immediately if an accident occurs.
- Remove all the external cables (including power cords) before moving the chassis.

- Do not work alone when you operate the device with the device powered on.
- Always verify that the power has been disconnected when you perform operations that require the device to be powered off.

## Laser safety

### **WARNING!**

Disconnected optical fibers or connectors might emit invisible laser light. Do not stare into beams or view directly with optical instruments when the switch is operating.

### **CAUTION:**

- Before you remove the optical fiber connector from a fiber port, execute the **shutdown** command in interface view to shut down the port.
- Insert a dust cap into any open optical fiber connector and a dust plug into any open fiber port or transceiver module port to protect them from contamination and ESD damage.

## Examining the installation site

The device can only be used indoors. To ensure correct operation and a long lifespan for your device, the installation site must meet the requirements in this section.

## Temperature and humidity

Maintain the temperature and humidity in the equipment room at acceptable levels.

- Lasting high relative humidity can cause poor insulation, electricity leakage, mechanical property change of materials, and metal corrosion.
- Lasting low relative humidity can cause washer contraction and ESD and bring problems including loose captive screws and circuit failure.
- High temperature can accelerate the aging of insulation materials and significantly lower the reliability and lifespan of the switch.

To ensure correct operation of the device, the equipment room must meet the temperature and humidity requirements listed in [Table 1](#).

**Table 1 Temperature/humidity requirements in the equipment room**

Temperature	Humidity
0°C to 45°C (32°F to 113°F)	5% RH to 95% RH, noncondensing

## Cleanliness

Dust buildup on the chassis can result in electrostatic adsorption, which causes poor contact of metal components and contact points, especially when indoor relative humidity is low. In the worst case, electrostatic adsorption can cause communication failure. To ensure correct operation, the equipment room must meet the dust concentration requirements listed in [Table 2](#).



**Table 2 Dust concentration limit in the equipment room**

Substance	Concentration limit (particles/m <sup>3</sup> )
Dust particles	≤ 3 x 10 <sup>4</sup> (No visible dust on desk in three days)
<b>NOTE:</b> Dust particle diameter ≥ 5 μm	

To eliminate corrosion and premature aging of components, the equipment room must also meet limits on salts, acids, and sulfides, as shown in [Table 3](#).

**Table 3 Harmful gas limits in an equipment room**

Gas	Max. (mg/m <sup>3</sup> )
SO <sub>2</sub>	0.2
H <sub>2</sub> S	0.006
NH <sub>3</sub>	0.05
Cl <sub>2</sub>	0.01
NO <sub>2</sub>	0.04

## Cooling

The device uses left-to-right airflow. For adequate heat dissipation, plan the installation site for the device based on its airflow direction and make sure the following requirements are met:

- A minimum clearance of 100 mm (3.94 in) is reserved around the air vents.
- The rack or workbench where the device is to be installed has a good ventilation system.

**Figure 1 Airflow through the chassis (WX3840H)**

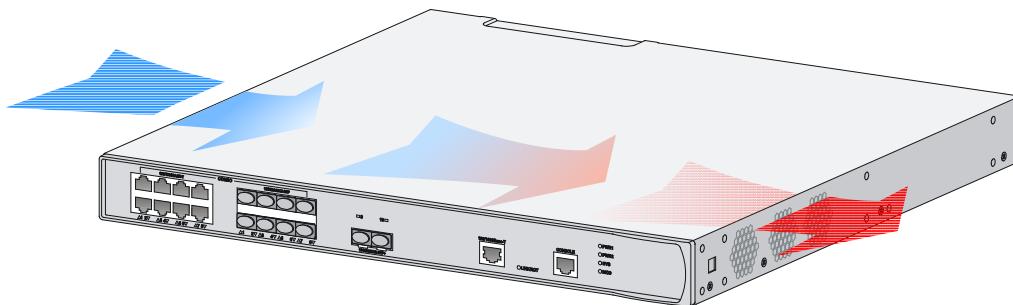

## ESD prevention

### ESD prevention guidelines

To prevent electrostatic discharge (ESD), follow these guidelines:

- Ground the device and rack or workbench reliably.
- Take dust-proof measures for the equipment room. For more information, see "[Cleanliness](#)."
- Maintain the humidity and temperature at acceptable levels. For more information, see "[Temperature and humidity](#)."

- Before working with the device, wear an ESD wrist strap or gloves and ESD garment, and remove conductive objects such as jewelry or watch. Make sure the wrist strap makes good skin contact and is reliably grounded.
- Always remember to wear an ESD wrist strap when working with a transceiver module.

### Attaching an ESD wrist strap

No ESD wrist strap is provided with the device. Prepare one yourself.

To attach an ESD wrist strap:

1. Wear the wrist strap on your wrist.
2. Lock the wrist strap tight around your wrist to maintain good contact with the skin.
3. Secure the wrist strap lock and the alligator clip lock together.
4. Attach the alligator clip to the rack.
5. Make sure the rack is reliably grounded.

**Figure 2 Attaching an ESD wrist strap (WX3840H)**

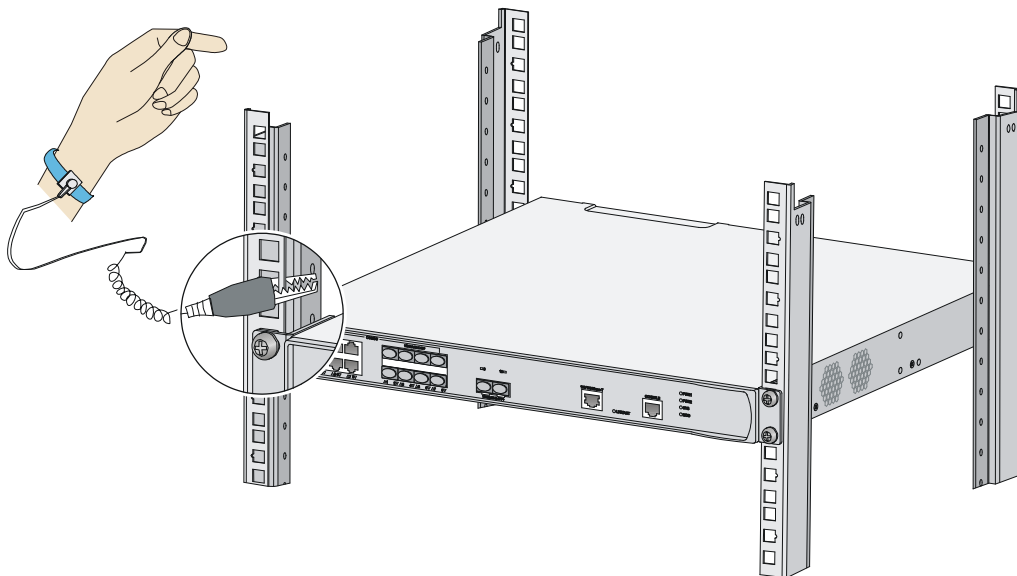

## EMI

All electromagnetic interference (EMI) sources, from outside or inside of the device and application system, adversely affect the device in the following ways:

- A conduction pattern of capacitance coupling.
- Inductance coupling.
- Electromagnetic wave radiation.
- Common impedance (including the grounding system) coupling.

To prevent EMI, perform the following tasks:

- If AC power is used, use a single-phase three-wire power receptacle with protection earth (PE) to filter interference from the power grid.
- Keep the device far away from radio transmitting stations, radar stations, and high-frequency devices.
- Use electromagnetic shielding, for example, shielded interface cables, when necessary.

- To prevent signal ports from getting damaged by overvoltage or overcurrent caused by lightning strikes, route interface cables only indoors. If you must route interface cables outdoors, install network port lightning protectors.

## Lightning protection





To better protect the device from lightning, follow these guidelines:

- Make sure the grounding cable of the chassis is reliably grounded.
- Make sure the grounding terminal of the AC power receptacle is reliably grounded.
- Install a lightning protector at the input end of the power module to enhance the lightning protection capability of the power supply.

## Installation accessories

The installation accessories vary by device model. [Table 4](#) describes the installation accessories available for the access controllers.

**Table 4 Installation accessories for the access controllers**

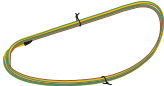
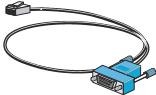
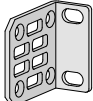
Accessory		WX3820H	WX3840H
Cage nut		4, user supplied	4, user supplied
M6 rack screw		4, user supplied	4, user supplied
M3 mounting bracket screw		8	8
Rubber feet		1 set	1 set
Grounding cable		1	1
Console cable		1	1
Front mounting bracket		2	2

## Installation tools

No installation tools are provided with the device. Prepare installation tools as required.

**Figure 3 Installation tools**

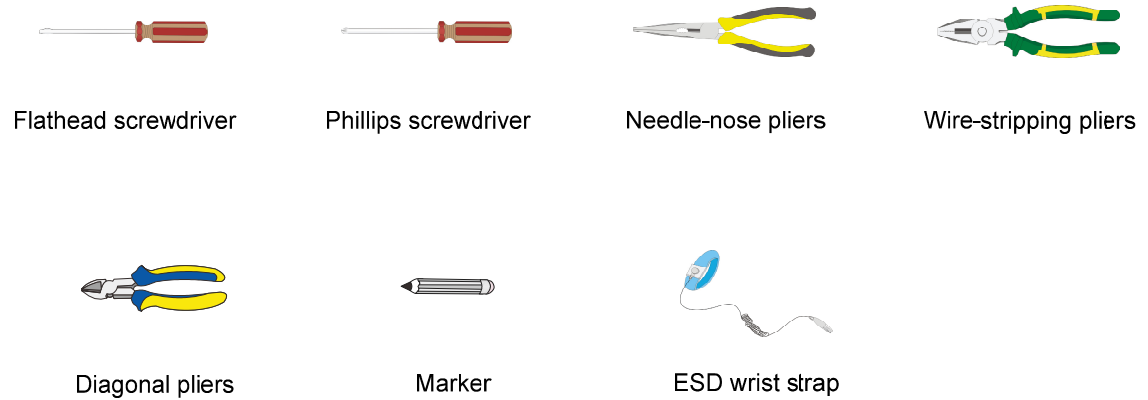

# Pre-installation checklist

**Table 5 Pre-installation checklist**

Item		Requirements	Result
Installation site	Ventilation	<ul style="list-style-type: none"> <li>There is a minimum clearance of 100 mm (3.94 in)) around the inlet and outlet vents for heat dissipation of the device chassis.</li> <li>A good ventilation system is available at the installation site.</li> </ul>	
	Temperature	0°C to 45°C (32°F to 113°F)	
	Humidity	5% RH to 95% RH (noncondensing)	
	Cleanliness	<ul style="list-style-type: none"> <li>Dust concentration <math>\leq 3 \times 10^4</math> particles/m<sup>3</sup></li> <li>No dust on desk within three days</li> </ul>	
	ESD prevention	<ul style="list-style-type: none"> <li>The equipment and rack or workbench are reliably grounded.</li> <li>The equipment room is dust-proof.</li> <li>The humidity and temperature are at acceptable levels.</li> <li>An ESD wrist strap is available.</li> </ul>	
	EMI prevention	<ul style="list-style-type: none"> <li>Effective measures are taken for filtering interference from the power grid.</li> <li>The protection ground of the device is away from the grounding facility of power equipment or lightning protection grounding facility.</li> <li>The device is far away from radio transmitting stations, radar stations, and high-frequency devices.</li> <li>Electromagnetic shielding, for example, shielded interface cables, is used as required.</li> </ul>	
	Lightning protection	<ul style="list-style-type: none"> <li>The device is reliably grounded.</li> <li>The AC power source is reliably grounded.</li> <li>(Optional.) Network port lightning protectors are available.</li> <li>(Optional.) A surge protected power strip is available.</li> </ul>	
Electricity safety	<ul style="list-style-type: none"> <li>A UPS is available.</li> <li>The power-off switch in the equipment room is identified and accessible so that the power can be</li> </ul>		

Item	Requirements	Result
	<p data-bbox="724 222 1219 250">immediately shut off when an accident occurs.</p> <ul data-bbox="671 267 1289 448" style="list-style-type: none"> <li data-bbox="671 267 1150 295">• The rack has a good ventilation system.</li> <li data-bbox="671 299 1289 355">• The rack is sturdy enough to support the weight of the device and installation accessories.</li> <li data-bbox="671 360 1246 388">• The size of the rack is appropriate for the device.</li> <li data-bbox="671 392 1289 448">• The front and rear of the rack are a minimum of 0.8 m (2.62 ft) away from walls or other devices.</li> </ul>	
Safety precautions	<ul data-bbox="453 470 1257 526" style="list-style-type: none"> <li data-bbox="453 470 1155 498">• The device is far away from any moist area and heat source.</li> <li data-bbox="453 502 1257 526">• You have located the emergency power switch in the equipment room.</li> </ul>	
Accessories	Accessories provided with the device are available.	
Reference	<ul data-bbox="453 599 1034 655" style="list-style-type: none"> <li data-bbox="453 599 1034 627">• Documents shipped with the device are available.</li> <li data-bbox="453 631 852 655">• Online documents are available.</li> </ul>	

# Contents

Installing the device .....	1
Confirming installation preparations .....	1
Installation flow .....	2
Mounting the device on a workbench .....	2
Installing the device in a 19-inch rack .....	3
Mounting bracket .....	3
Mounting the device in a rack .....	3
Grounding the device .....	5
Grounding the device by using a grounding strip .....	5
Grounding the device by using a grounding point on the rack .....	6
Grounding the device by using a grounding conductor buried in the earth .....	7
(Optional) Installing network port lightning protectors .....	8
(Optional) Installing a surge protected power strip .....	9
Connecting interface cables .....	9
Connecting the console cable and setting terminal parameters .....	9
Connecting Ethernet cables .....	10
Installing a power module .....	11
Connecting a power cord .....	12
Verifying the installation .....	12
Starting the device .....	12

# Installing the device

---



## **WARNING!**

Keep the tamper-proof seal on a mounting screw on the chassis cover intact, and if you want to open the chassis, contact H3C Support for permission. Otherwise, H3C will not be liable for any consequence caused thereby.

---

The installation procedure is the same for the WX3800H series access controllers. This section uses the WX3840H access controller as an example.

## Confirming installation preparations

Before you install the device, verify that you have read "Preparing for installation" carefully and the installation site meets all the requirements.

# Installation flow

Figure 1 Installation flow

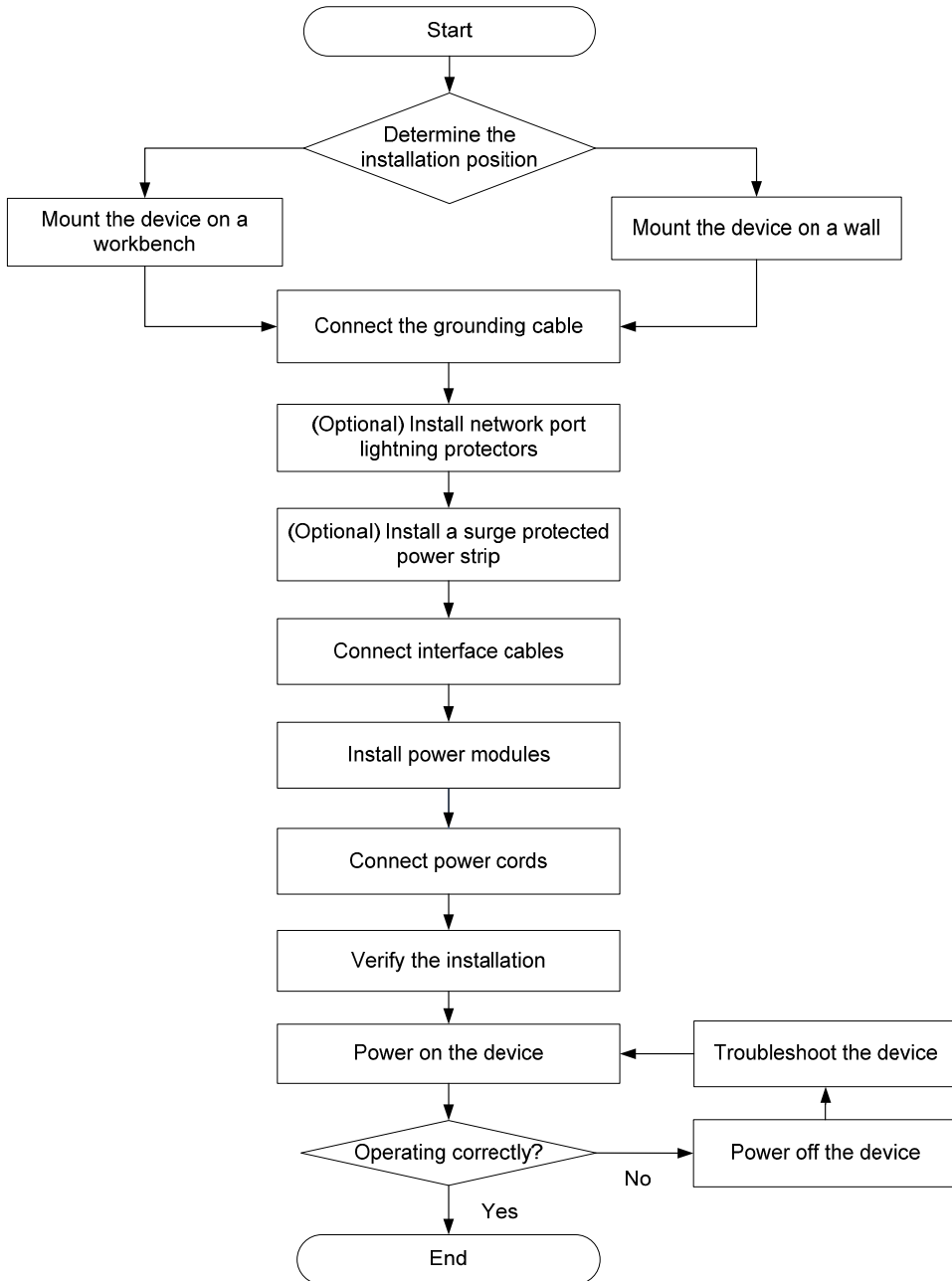

## Mounting the device on a workbench

---

**⚠ CAUTION:**  
Do not place heavy objects on the device.

---

If a standard 19-inch rack is not available, you can mount the device on a clean, flat workbench.  
To mount the device on a workbench:



1. Place the device upside down. Clean the recessed areas on the chassis bottom.
2. Attach the four rubber feet to the recessed areas on the chassis bottom.
3. Place the device on the workbench with the upside up. Make sure the four rubber feet stand firmly on the workbench.

**Figure 2 Mounting the device on a workbench**

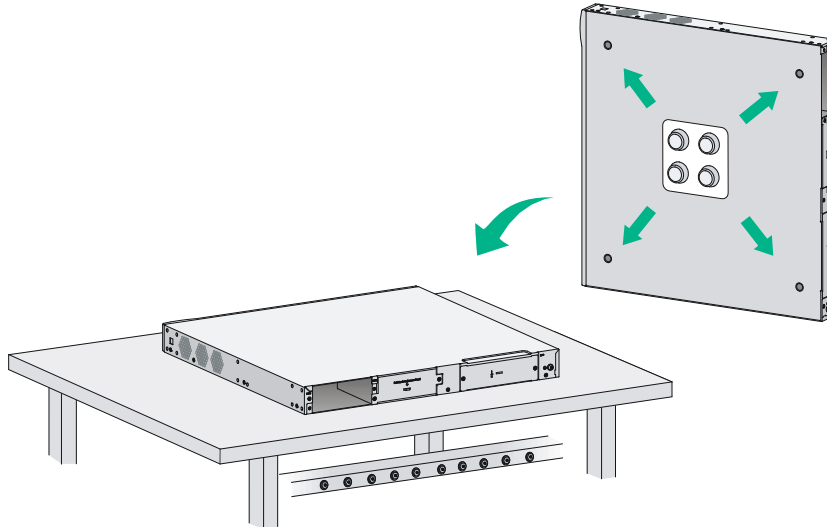

## Installing the device in a 19-inch rack

**! IMPORTANT:**

Keep a minimum distance of 1 U (44.45 mm, or 1.75 in) between adjacent devices for good heat dissipation.

## Mounting bracket

**Figure 3 Mounting bracket**

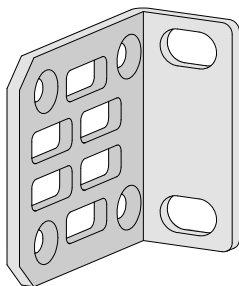

## Mounting the device in a rack

1. Attach cage nuts to the front rack posts:
  - a. Wear the ESD wrist strap and make sure the rack is stable and is reliably grounded.
  - b. Use a mounting bracket to mark cage nut installation positions on the two front rack posts.
  - c. Install cage nuts into the marked square holes on the front rack posts.

**Figure 4 Installing cage nuts**

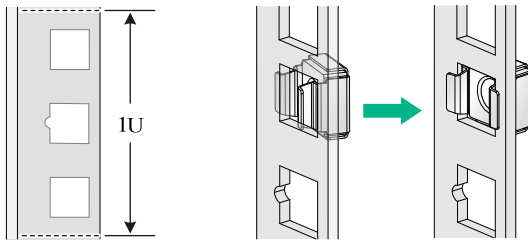

2. Use the M3 screws supplied with the mounting brackets to secure the mounting brackets to both sides of the device.

**Figure 5 Installing the mounting brackets**

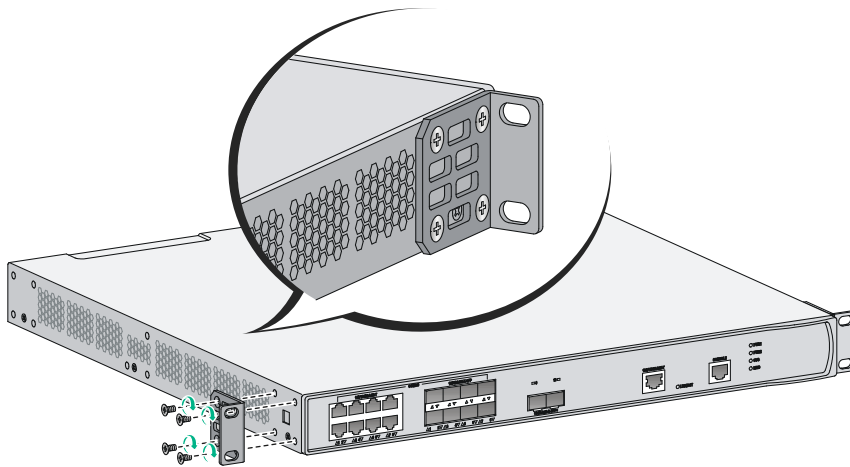

3. Supporting the device bottom with one hand and holding the device front with the other, place the device gently in the rack. Use M6 rack screws to attach the mounting brackets on the device to the front rack posts.

Figure 6 Installing the device in the rack

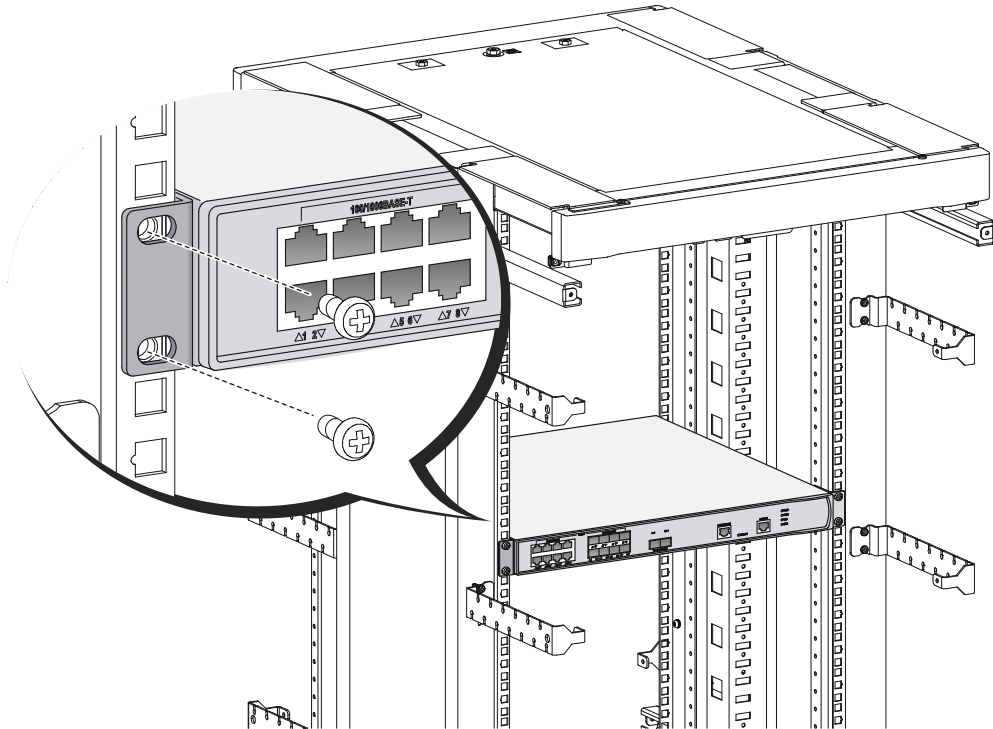

## Grounding the device

---

**⚠ WARNING!**

- Correctly connecting the grounding cable is crucial to lightning protection and EMI protection.
  - Connect the grounding cable to the grounding system in the equipment room. Do not connect it to a fire main or lightning rod.
- 

## Grounding the device by using a grounding strip

1. Connect the grounding cable to the device.
  - a. Use a Phillips screwdriver to remove the grounding screw from the grounding hole in the rear panel of the chassis.
  - b. Use the grounding screw to attach the ring terminal of the grounding cable to the grounding hole and fasten the screw.
2. Connect the other end of the grounding cable to the grounding strip. Make sure the grounding strip is reliably grounded.

**Figure 7 Grounding the device by using a grounding strip**

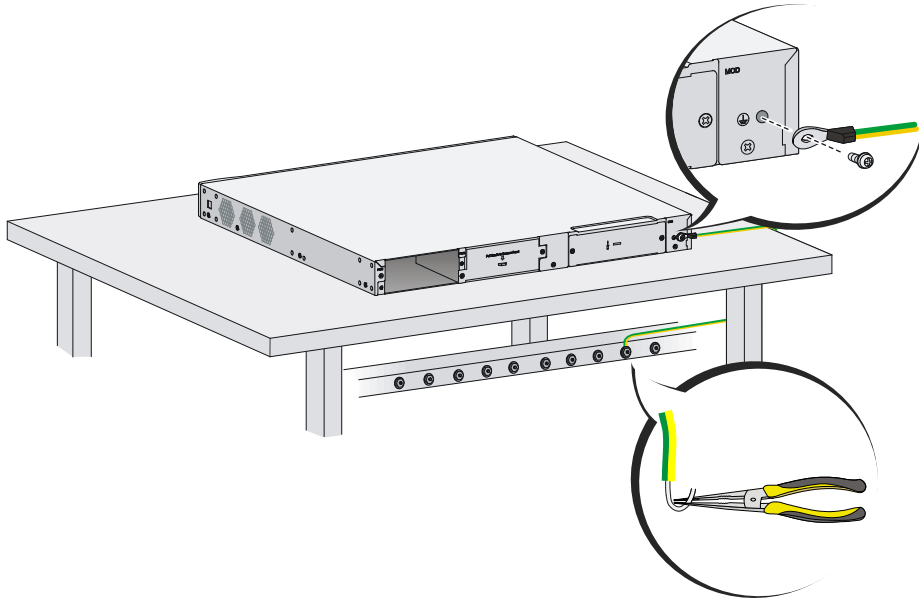

## Grounding the device by using a grounding point on the rack

**⚠ CAUTION:**

To ground the device by using a grounding point on the rack, make sure the rack is reliably grounded.

To ground the device by using a grounding point on the rack:

1. Connect the grounding cable to the device. For the connection procedure, see "[Grounding the device by using a grounding strip.](#)"
2. Connect the other end of the grounding cable to a grounding point on the rack.

**Figure 8 Grounding the device by using a grounding point the rack**

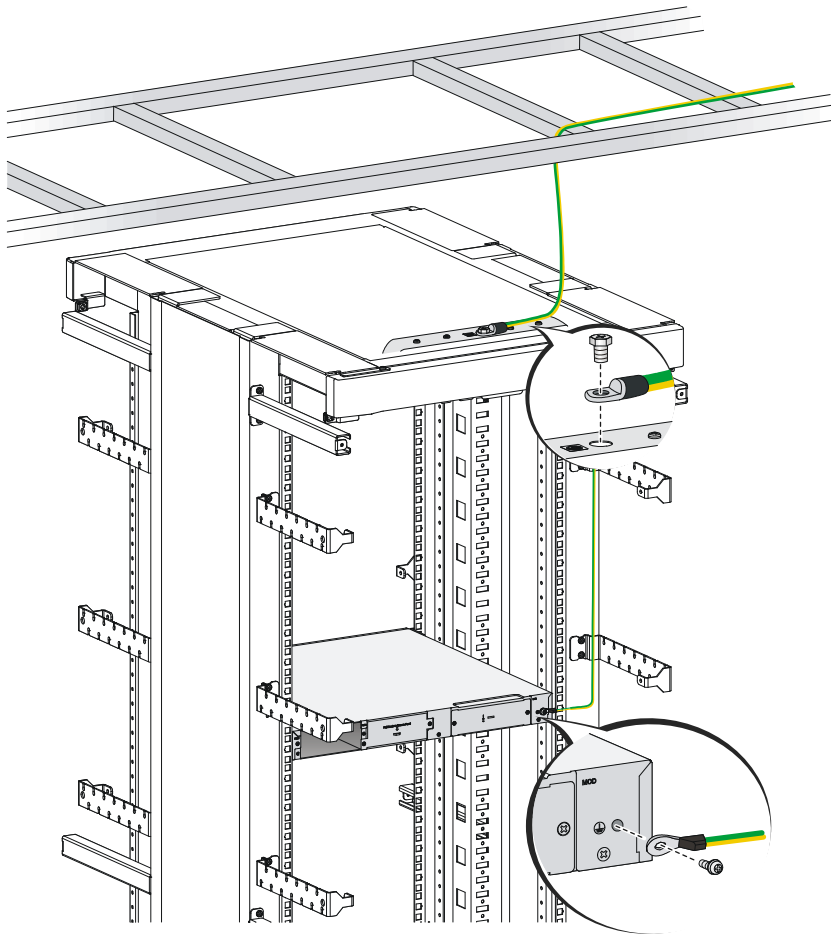

## Grounding the device by using a grounding conductor buried in the earth

If earth is available at the installation site, hammer a 0.5 m (1.64 ft) or longer angle iron or steel tube into the earth to serve as a grounding conductor. Weld the yellow-green grounding cable to the angle iron or steel tube and treat the joint for corrosion protection.

**Figure 9 Grounding the device by burying a grounding conductor into the earth**

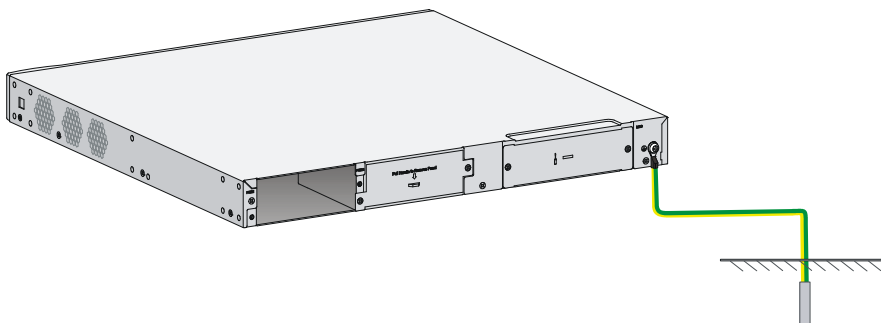

# (Optional) Installing network port lightning protectors

---

## ⓘ **IMPORTANT:**

- Before installing a network port lightning protector, read the instructions in the document that comes with the protector.
  - Network port lightning protectors are available only for 10M/100M/1000M RJ-45 Ethernet copper ports.
  - If multiple network ports have network cables routed outdoors, install a network port lightning protector for each network port.
- 

If part of the network cable for a network port is routed outdoors, install a network port lightning protector for the port to protect against damages caused by lightning strikes.

No network port lightning protectors are provided with the device. Purchase them yourself as required.

To install a network port lightning protector for a network port:

1. Use a double-faced adhesive tape to stick the network port lightning protector onto the device chassis, and make sure it is as close to the grounding screw of the device as possible.
2. Cut the ground wire of the protector to a length (as short as possible) as required by the distance between the protector and the grounding screw of the device. Attach the ground wire securely to the grounding screw of the device.

Make sure the grounding screw of the device is reliably grounded.

3. Use a multimeter to verify that the ground wire of the protector makes good contact with the grounding screw of the chassis.
4. Insert the outdoor network cable into the protector's Surge end marked **IN**, and insert the cable from the network port into the Protect end marked **OUT**.
5. Examine the port LED to verify that the port is operating correctly.

Figure 10 Installing a lightning protector for a network port

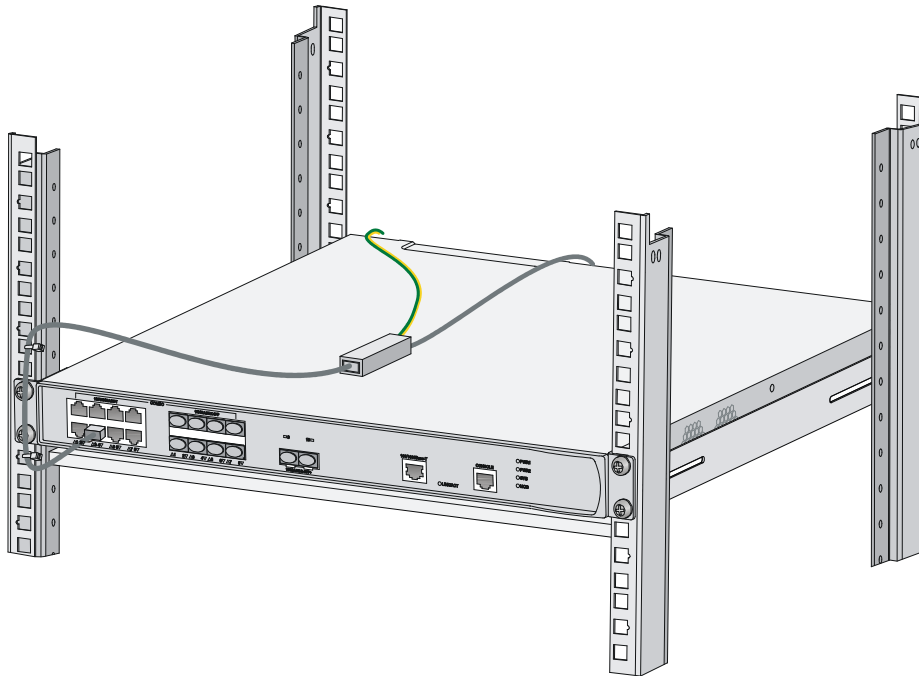

## (Optional) Installing a surge protected power strip

### ⚠ IMPORTANT:

Before installing a surge protected power strip, read the instructions in the document that comes with the strip.

If you use an AC power line routed from outdoors for the device, use a surge protected power strip for the device to protect against damages caused by lightning strikes. No surge protected power strip is provided with the device. Purchase one yourself if required.

To use a surge protected power strip, first connect the AC power line routed from outdoors to the strip and then connect the power cord from the device to the strip.

You can attach the surge protected power strip to the rack, workbench, or wall of the equipment room.

## Connecting interface cables

### Connecting the console cable and setting terminal parameters

To configure and manage the device from the console port, you must run a terminal emulator program, TeraTermPro or PuTTY, on your configuration terminal. For more information about the terminal emulator programs, see the user guides for these programs

The following are the required terminal settings:

- **Bits per second**—9600.
- **Data bits**—8.

- **Stop bits**—1.
- **Parity**—None.
- **Flow control**—None.

## Connecting Ethernet cables

### Connecting an Ethernet copper port

1. Connect one end of the Ethernet cable to an Ethernet copper port on the device, and the other end to an Ethernet port on the peer device.
2. After powering on the device, examine the LEDs of the fixed copper Ethernet port.  
For more information about the LED description, see "Appendix B LEDs."

### Connecting a fiber port

---

**⚠ WARNING!**

Disconnected optical fibers or connectors might emit invisible laser light. Do not stare into beams or view directly with optical instruments when the switch is operating.

---

**⚠ CAUTION:**

- To connect a fiber port by using an optical fiber, first install a transceiver module in the port and then connect the optical fiber to the transceiver module.
  - Insert a dust cap into any open optical fiber connector and a dust plug into any open fiber port or transceiver module port to protect them from contamination and ESD damage.
  - Never bend an optical fiber excessively. The bend radius of an optical fiber must be not less than 100 mm (3.94 in).
  - Keep the fiber end clean.
  - Make sure the Tx and Rx ports on a transceiver module are connected to the Rx and Tx ports on the peer end, respectively.
- 

No transceiver modules are provided with the device. Purchase transceiver modules yourself as required. For transceiver module specifications, see "Appendix A Chassis views and technical specifications."

The fiber ports on the device support only LC connectors.

To connect an optical fiber for a fiber port:

1. Remove the dust plug from the fiber port.
2. Pivot the bail latch of the transceiver module up so that it catches a knob on the top of the transceiver module.
3. Holding both sides of the transceiver module, insert the transceiver module slowly into the port.
4. Identify the Rx and Tx ports on the transceiver module. Use the optical fiber to connect the Rx port and Tx port on the transceiver module to the Tx port and Rx port on the peer end, respectively.
5. Examine the port LEDs:
  - If the LED is on, a fiber link has been set up.
  - If the LED is off, the link has not been set up. The reason might be wrong connection of the Tx and Rx ends. Swap the fiber cables in the Tx and Rx ports at one end of the fiber connection.



**Figure 11 Connecting an optical fiber**

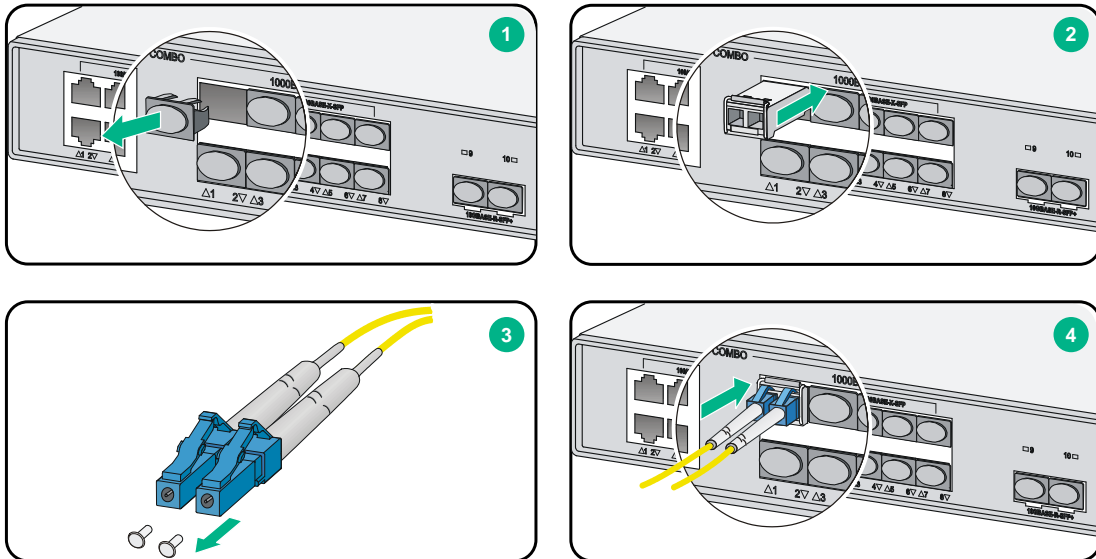

## Installing a power module

The device supports only AC power modules.

To install a power module:

1. Remove the blank filler panel (if any) from the slot where you want to install a power module with a Phillips screwdriver.  
Keep the removed blank filler panel for future use.
2. Holding the handle of the power module with one hand and supporting the bottom of the power module with another hand, push the power module into the slot along the guide rails until the power module is completely inserted.
3. Use a Phillips screwdriver to fasten the screws on the power module.

**Figure 12 Installing an AC power module**

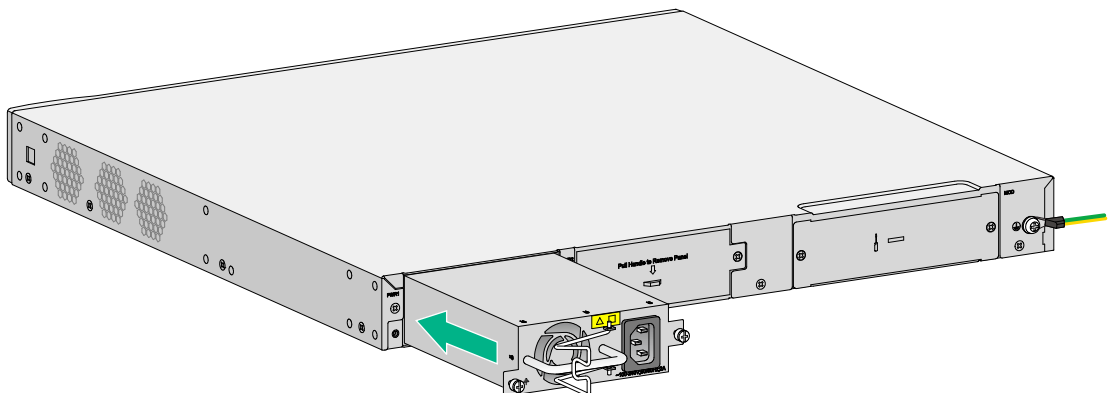

# Connecting a power cord

## **⚠ CAUTION:**

Before powering on the device, make sure the device is reliably grounded.

After you connect a power cord for the device, examine the power module status LED to verify that the power module is operating correctly. For the power module LED description, see "Appendix B LEDs."

To connect an AC power cord:

1. Pivot the bail latch leftwards.
2. Connect one end of the AC power cord to the AC-input power receptacle on the device.
3. Pivot the bail latch rightwards to secure the power cord.
4. Connect the other end of the AC power cord to the AC power source.

**Figure 13 Connecting an AC power cord**

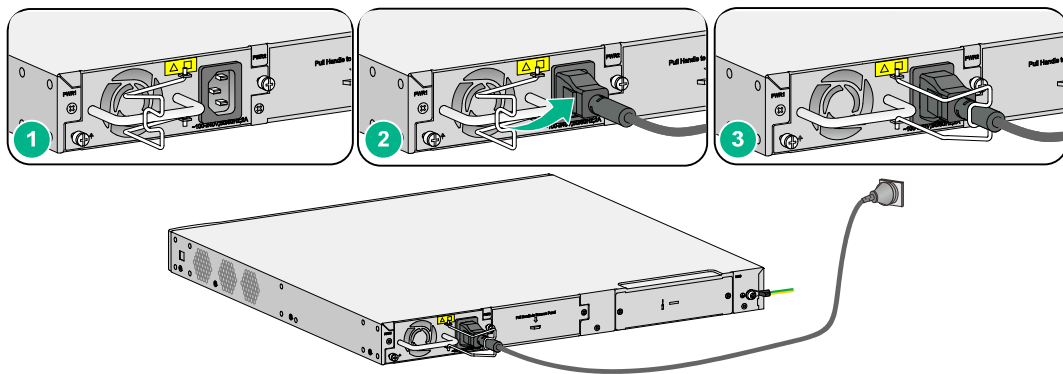

# Verifying the installation

Before powering on the device, verify the following items:

- There is enough space around the device for heat dissipation.
- The rack or workbench is stable.
- The power source specifications are as required by the device.
- The grounding cable, console cable, power cords, and interface cables are connected correctly.
- If part of the network cable for a port is routed outdoors, verify that a network port lightning protector is used for the port.
- If the power line is routed from outdoors, verify that a surge protected power strip is used for the device.

# Starting the device

The following procedure uses the WX3840H access controller as an example.

To start the device:

1. Power on the device. The device initializes its memory and runs the BootWare. The following information appears on the terminal screen:

```
System is starting...
```

```
Press Ctrl+D to access BASIC-BOOTWARE MENU
```

Press Ctrl+T to start heavy memory test  
Booting Normal Extended BootWare  
The Extended BootWare is self-decompressing.....Done.

```
*****  
*                                                                 *  
*           H3C WX3840H BootWare, Version 5.12                   *  
*                                                                 *  
*****  
Copyright (c) 2004-2018 New H3C Technologies Co., Ltd.
```

```
Compiled Date       : Jan 15 2018  
CPU Type           : XLP432  
CPU Clock Speed    : 1400MHz  
Memory Type        : DDR3 SDRAM  
Memory Size        : 16384MB  
Memory Speed       : 1333MHz  
BootWare Size      : 768KB  
Flash Size         : 16MB  
cfa0 Size          : 4002MB  
CPLD1 Version      : 003  
PCB Version        : Ver.A
```

BootWare Validating...  
Press Ctrl+B to access EXTENDED-BOOTWARE MENU...

**2. Press Ctrl + B at the prompt within 4 seconds to access the BootWare menu.**

To access the BootWare menu after the system enters the system image file reading and self-compressing process, restart the device.

```
Loading the main image files...  
Loading file cfa0:/system.bin.....  
.....Done.  
Loading file cfa0:/boot.bin.....  
.....  
.....  
.....Done.
```

```
Image file cfa0:/boot.bin is self-decompressing.....  
.....Done.
```

```
System image is starting...  
Cryptographic Algorithms Known-Answer Tests are running ...  
CPU 0 of slot 1:  
Starting Known-Answer tests in the user space.  
Known-answer test for SHA1 passed.  
Known-answer test for SHA224 passed.  
Known-answer test for SHA256 passed.  
Known-answer test for SHA384 passed.  
Known-answer test for SHA512 passed.
```

```
Known-answer test for HMAC-SHA1 passed.
Known-answer test for HMAC-SHA224 passed.
Known-answer test for HMAC-SHA256 passed.
Known-answer test for HMAC-SHA384 passed.
Known-answer test for HMAC-SHA512 passed.
Known-answer test for AES passed.
Known-answer test for RSA(signature/verification) passed.
Known-answer test for RSA(encrypt/decrypt) passed.
Known-answer test for DSA(signature/verification) passed.
Known-answer test for random number generator passed.
Known-Answer tests in the user space passed.
Starting Known-Answer tests in the kernel.
Known-answer test for AES passed.
Known-answer test for HMAC-SHA1 passed.
Known-answer test for SHA1 passed.
Known-answer test for GCM passed.
Known-answer test for GMAC passed.
Known-answer test for random number generator passed.
Known-Answer tests in the kernel passed.
Cryptographic Algorithms Known-Answer Tests passed.
Line con0 is available.
```

Press ENTER to get started.

3. Press **Enter** at the prompt, and you can configure the device when the prompt **<H3C>** appears.

---

**NOTE:**

The CPLD version is automatically upgraded to the latest version during the start-up process.

---

# Contents

Troubleshooting .....	1
Power module failure .....	1
Symptom .....	1
Solution .....	1
No display or garbled display on the configuration terminal .....	1
Symptom .....	1
Solution .....	1
Software loading failure .....	2
Symptom .....	2
Solution .....	2

# Troubleshooting

## Power module failure

### Symptom

The device cannot be powered on. The power module status LED (PWR) is off, or the system status LED (SYS) is off.

### Solution

To resolve the issue:

1. Verify that the power source is as required.
2. Verify that the power cord is connected securely.
3. Verify that the power cord is in good condition.
4. If the issue persists, contact H3C Support.

## No display or garbled display on the configuration terminal

### Symptom

The configuration terminal does not have display or have a garbled display when the device is powered on.

### Solution

To resolve the issue:

1. Verify that the power system is operation correctly.
2. Verify that the console cable is connected correctly to the specified serial port on the configuration terminal.
3. Verify that the following settings are configured for the terminal:
  - **Baud rate**—9,600.
  - **Data bits**—8.
  - **Parity**—none.
  - **Stop bits**—1.
  - **Flow control**—none.
  - **Emulation**—VT100.
4. Verify that the console cable is in good condition.
5. If the issue persists, contact H3C Support.

# Software loading failure

## Symptom

The device fails in software loading.

## Solution

To resolve the issue:

1. Verify that the physical ports are connected securely and correctly. If a port is not connected securely, reconnect the port and make sure the connections are correct.
2. View the software loading process displayed on the HyperTerminal to check for errors. If an error exists, correct the error.

For example, check for the following errors that might occur:

- When you use XMODEM to load software, you select a baud rate other than 9600 bps, but you have not reset the baud rate for the HyperTerminal.
  - When you use TFTP to load software, you entered an incorrect IP address, software name, or TFTP serve path.
  - When you use FTP to load software, you entered an incorrect IP address, software name, username, or password.
3. If the issue persists, contact H3C Support.

# Contents

Hardware management and maintenance .....	1
Displaying hardware information for the device.....	1
Displaying operational statistics for the device .....	2
Displaying information about the device .....	3
Displaying the electronic label data for the device.....	3
Displaying the CPU usage of the device.....	4
Displaying the memory usage of the device .....	4
Displaying the operational status of the built-in fans .....	5
Displaying the operating state of power modules.....	5
Rebooting the device .....	5
Restrictions and guidelines .....	6
Configuration procedure .....	6



# Hardware management and maintenance

The command lines and outputs depend on the software version that runs on the device.

This section uses the command outputs on the WX3840H access controller as an example.

## Displaying hardware information for the device

Use the **display version** command to display software and hardware version information about the device. The output includes the following information:

- The current software.
- The hardware version.
- The device operating time.

The output depends on the software and hardware versions of the device.

```
<H3C> display version
H3C Comware Software, Version 7.1.064, Alpha Release 5323
Copyright (c) 2004-2018 New H3C Technologies Co., Ltd. All rights reserved.
H3C WX3840H uptime is 0 weeks, 1 day, 20 hours, 47 minutes
Last reboot reason : User soft reboot
```

```
Boot image: cfa0:/boot.bin
Boot image version: 7.1.064, Release 5323
  Compiled Feb 01 2018 16:00:00
System image: cfa0:/system.bin
System image version: 7.1.064, Release 5323
  Compiled Feb 01 2018 16:00:00
```

```
Slot 1
Uptime is 0 week, 1 day, 20 hours, 47 minutes
with 1 1400MHz Multi-core Processor
16096M bytes DDR3
16M bytes NorFlash Memory
4002M bytes CFCard Memory
```

```
Hardware Version is Ver.A
CPLD Version is 003
Basic Bootrom Version is 5.06
Extend Bootrom Version is 5.12
[Subslot 0]WX3840H Hardware Version is Ver.A
```

# Displaying operational statistics for the device

When you perform routine maintenance or the system fails, you might need to display the operational information of each feature module to locate failures. Typically, you need to run the **display** commands individually. However, you can use the **display diagnostic-information** command in any view to display or save the operational statistics of multiple feature modules of the device. This command displays the output of the **display clock**, **display version**, **display device**, and **display current-configuration** commands.

- Save the operational statistics for each feature module of the device:

```
<H3C>display diagnostic-information
Save or display diagnostic information (Y=save, N=display)? [Y/N]:y
Please input the file name(*.tar.gz)[cfa0:/diag_WX3840H_20170420-015630.tar.gz]:
Diagnostic information is outputting to cfa0:/diag_WX3840H_20170420-015630.tar.g
z.
Please wait...
Save successfully.
```

To view the contents of the XXXX.tar.gz file, perform the following steps:

- a. Execute the **tar extract** command to extract the XXXX.gz file from the XXXX.tar.gz file.
  - b. Execute the **gunzip** command to decompress the XXXX.gz file to XXXX file.
  - c. Execute the **more** command to view the XXXX file.
- Display the operational statistics for each feature module of the device. (Details not shown.)

```
<H3C>display diagnostic-information
Save or display diagnostic information (Y=save, N=display)? [Y/N]:n
=====
=====display clock=====
09:36:55 UTC Mar 01/01/2018
=====
=====display version=====
H3C Comware Software, Version 7.1.064, Release 5323
Copyright (c) 2004-2018 New H3C Technologies Co., Ltd. All rights reserved.
H3C WX3840H uptime is 0 weeks, 0 days, 18 hours, 28 minutes
Last reboot reason : User soft reboot

Boot image: cfa0:/boot.bin
Boot image version: 7.1.064, Release 5323
  Compiled Mar 21 2017 16:00:00
System image: cfa0:/system.bin
System image version: 7.1.064, Release 5323
  Compiled Mar 21 2017 16:00:00

Slot 1
Uptime is 0 week, 2 days, 1 hour, 3 minutes
with 1 1000MHz Multi-core Processor
4064M bytes DDR3
16M bytes NorFlash Memory
4002M bytes CFCard Memory
```

```

Hardware Version is Ver.A
CPLD Version is 003
Basic Bootrom Version is 5.06
Extend Bootrom Version is 5.12
[Subslot 0]WX3840H Hardware Version is Ver.A
...

```

## Displaying information about the device

Use the **display device** command to display information about the device.

```

<H3C> display device
Slot No.   Subslot No. Board Type      Status   Max Ports
1          0          WX3840H       Normal   19

```

**Table 1 Command output**

Field	Description
Board Type	Device type.
Status	Device status: <ul style="list-style-type: none"> <li>• <b>Fault</b>—The device is faulty and cannot start up correctly.</li> <li>• <b>Normal</b>—The device is operating correctly.</li> </ul>
Max Ports	Maximum number of ports supported.

## Displaying the electronic label data for the device

An electronic label is a profile of a device. It contains the permanent configuration, including the serial number, manufacturing date, MAC address, and vendor name.

Use the **display device manuinfo** command to display the electronic label data for the device.

```

<H3C>display device manuinfo
Slot 1 CPU 0:
DEVICE_NAME:WX3840H
DEVICE_SERIAL_NUMBER:210235A1JNC14B900031
MAC_ADDRESS:000f-e212-6103
MANUFACTURING_DATE:2018-03-08
VENDOR_NAME:H3C

```

**Table 2 Command output**

Field	Description
DEVICE_NAME	Device model.
DEVICE_SERIAL_NUMBER	Serial number of the device.
MAC_ADDRESS	MAC address of the device.
MANUFACTURING_DATE	Manufacturing data of the device.
VENDOR_NAME	Vendor name.

## Displaying the CPU usage of the device

Use the **display cpu-usage** command to display the CPU usage statistics for the device.

```
<H3C> display cpu-usage
Slot 1 CPU 0 CPU usage:
    0% in last 5 seconds
    0% in last 1 minute
    1% in last 5 minutes
```

**Table 3 Command output**

Field	Description
Slot 1 CPU 0 CPU usage	Usage of CPU 0 on IRF member device 1.
0% in last 5 seconds	Average CPU usage in the last 5 seconds (after the device boots, the device calculates and records the average CPU usage at the interval of 5 seconds).
0% in last 1 minute	Average CPU usage in the last minute (after the device boots, the device calculates and records the average CPU usage at the interval of 1 minute).
1% in last 5 minutes	Average CPU usage in the last 5 minutes (after the device boots, the device calculates and records the average CPU usage at the interval of 5 minutes).

## Displaying the memory usage of the device

Use the **display memory** command to display the memory usage statistics for the device.

```
<H3C> display memory
Memory statistics are measured in KB:
Slot 1:
      Total      Used      Free      Shared      Buffers      Cached      FreeRatio
Mem:    3775116  1042200  2732916         0        160    194828      72.4%
-/+ Buffers/Cache:    847212  2927904
Swap:         0         0         0
```

**Table 4 Command output**

Field	Description
Mem	Memory usage information.
Total	Total size of the physical memory space that can be allocated.
Used	Used physical memory.
Free	Free physical memory.
Shared	Physical memory shared by processes.
Buffers	Physical memory used for buffers.
Cached	Used physical memory for cache.
FreeRatio	Free memory ratio.

Field	Description
-/+ Buffers/Cache	<ul style="list-style-type: none"> <li>-/+ Buffers/Cache:used = Mem:Used – Mem:Buffers – Mem:Cached, which indicates the physical memory used by applications.</li> <li>-/+ Buffers/Cache:free = Mem:Free + Mem:Buffers + Mem:Cached, which indicates the physical memory available for applications.</li> </ul>
Swap	Swap memory.

## Displaying the operational status of the built-in fans

Use the **display fan** command to display the operating states of fans.

```
<H3C> display fan
Fan 1 State: Normal
Fan 2 State: Normal
Fan 3 State: Normal
```

**Table 5 Command output**

Field	Description
Fan <i>n</i>	Fan No..
State	Fan state: <ul style="list-style-type: none"> <li><b>Normal</b>—The fan is operating correctly.</li> <li><b>Absent</b>—The fan is not in position.</li> <li><b>Fault</b>—The fan has failed.</li> </ul>

## Displaying the operating state of power modules

Use the **display power** command to display the operating state of power modules.

```
<H3C> display power
Power 1 State: Normal
Power 2 State: Absent
```

**Table 6 Command output**

Field	Description
Power 1, 2	Power module No..
State	Power module state: <ul style="list-style-type: none"> <li><b>Normal</b>—The power module is operating correctly.</li> <li><b>Absent</b>—The power module is not in position.</li> <li><b>Fault</b>—The power module has failed.</li> </ul>

## Rebooting the device

To reboot the device, use one of the following methods:

- Reboot the device at the CLI. You can remotely reboot the device in either of the following ways:
  - Reboot the device immediately by using the **reboot** command.

- Schedule a reboot to occur at a specific time or date or after a delay by using the **schedule reboot** command.
- Power off and power on the device. This method cuts off the power of the device forcibly, which might cause data loss. It is the least-preferred method.

## Restrictions and guidelines

- Before you reboot the device, perform the following tasks:
  - Use the **save** command to save the running configuration. For more information about the **save** command, see configuration file management commands in *H3C WX3800H Series Access Controllers Fundamentals Command Reference*.
  - Use the **display startup** and **display boot-loader** commands to verify that you have specified the correct next-startup configuration files and startup software images. If the main startup software image is corrupt or does not exist, a reboot failure will occur. To avoid a reboot failure, use the **boot-loader file** command to specify a new startup software image. For more information about the **display startup** and **display boot-loader** commands, see software upgrade commands in *H3C WX3800H Series Access Controllers Fundamentals Command Reference*.
- The device will not reboot if a file is being accessed.

## Configuration procedure

### Rebooting the device immediately

Task	Command	Remarks
Reboot the device immediately.	<b>reboot [ force ]</b>	Available in user view.

### Scheduling a reboot for the device

Task	Command	Remarks
Schedule a reboot.	<ul style="list-style-type: none"> <li>● Schedule a reboot to occur at a specific time or date: <b>schedule reboot at time [ date ]</b></li> <li>● Schedule a reboot to occur after a delay: <b>schedule reboot delay time</b></li> </ul>	<p>Use either command.</p> <p>By default, no reboot date or time or reboot delay time is specified.</p> <p>Available in user view.</p> <p>The most recent configuration takes effect if you execute the <b>scheduler reboot at</b> or <b>scheduler reboot delay</b> command multiple times.</p>

# Contents

Appendix A Chassis views and technical specifications .....	1
Chassis views .....	1
WX3820H .....	1
WX3840H .....	1
Power module views .....	2
Interface numbering .....	2
Technical specifications .....	2

# Appendix A Chassis views and technical specifications

## Chassis views

### WX3820H

Figure 1 Front panel

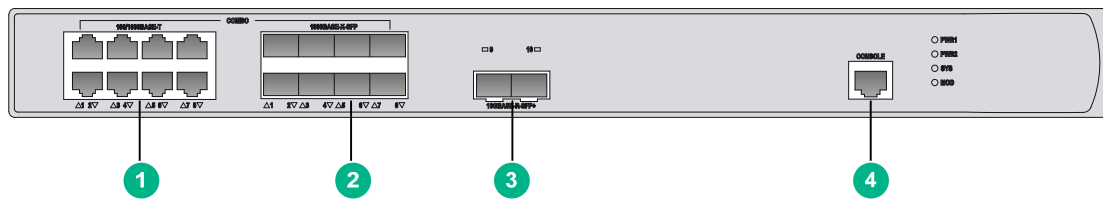

(1) 100/1000BASE-T autosensing Ethernet copper ports 1 through 8 (combo interfaces)

(2) 100BASE-FX/1000BASE-X SFP ports 1 through 8 (combo interfaces)

(3) 10GBASE-R SFP+ ports 9 and 10

(4) Console port

Figure 2 Rear panel

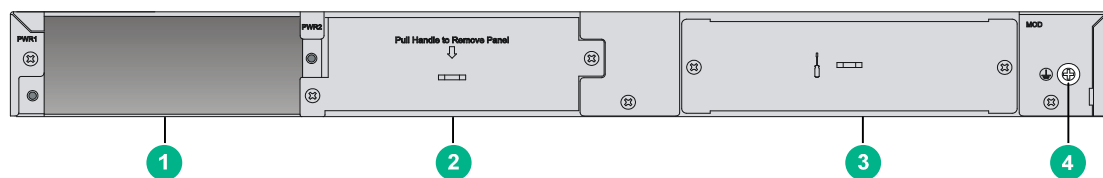

(1) Power module slot 1 (PWR1)

(2) Power module slot 2 (PWR2)

(3) Slot reserved for future use

(4) Grounding screw

### WX3840H

Figure 3 Front panel

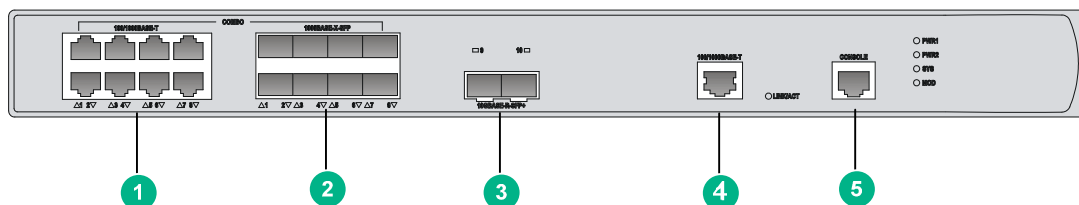

(1) 100/1000BASE-T autosensing Ethernet copper ports 1 through 8 (combo interfaces)

(2) 100BASE-FX/1000BASE-X SFP ports 1 through 8 (combo interfaces)

(3) 10GBASE-R SFP+ ports 9 and 10

(4) 100/1000BASE-T management Ethernet port

(5) Console port



Figure 4 Rear panel

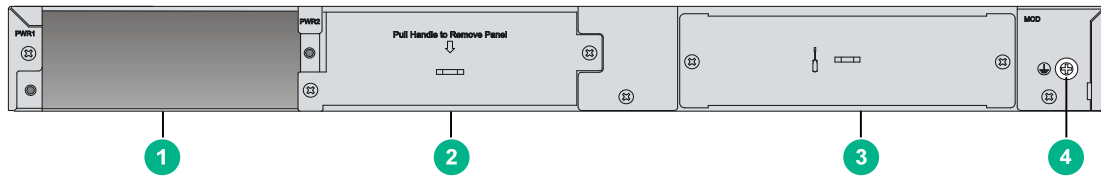

- |                                  |                                |
|----------------------------------|--------------------------------|
| (1) Power module slot 1 (PWR1)   | (2) Power module slot 2 (PWR2) |
| (3) Slot reserved for future use | (4) Grounding screw            |

## Power module views

Figure 5 AC power module

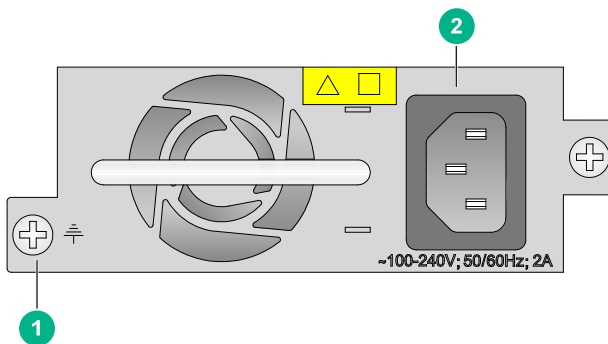

- |                   |                      |
|-------------------|----------------------|
| (1) Captive screw | (2) Power receptacle |
|-------------------|----------------------|

## Interface numbering

A combo interface is a logical interface that contains a fiber port and a copper port. Only one port is activated at a time. By default, the copper port is activated.

Fixed ports on the WX3820H and WX3840H access controllers are numbered as follows:

- 100/1000BASE-T autosensing Ethernet copper ports 1 through 8 form combo interfaces (represented by interface numbers GigabitEthernet 1/0/1 through GigabitEthernet 1/0/8) with 100BASE-FX/1000BASE-X SFP ports 1 through 8, respectively.
- 10GBASE-R SFP+ ports 9 and 10 are represented by interface numbers GigabitEthernet 1/0/9 and GigabitEthernet 1/0/10, respectively.

## Technical specifications

Table 1 Technical specifications

Item	WX3820H	WX3840H
Console port	One, 9600 bps (default) to 115200 bps	One, 9600 bps (default) to 115200 bps
GE port	8 × 100/1000BASE-T autosensing Ethernet copper ports	8 × 100/1000BASE-T autosensing Ethernet copper ports
Management Ethernet port	N/A	1 × 100/1000BASE-T management Ethernet port

Item	WX3820H	WX3840H
SFP port	8 × 100BASE-FX/1000BASE-X SFP ports	8 × 100BASE-FX/1000BASE-X SFP ports
SFP+ port	2 × 10GBASE-R SFP+ ports	2 × 10GBASE-R SFP+ ports
Memory	1 × 8GB DDR3	2 × 8GB DDR3s
Storage media	4GB CF Card	4GB CF Card
Dimensions (H × W × D) (excluding rubber feet and mounting brackets)	43.6 × 440 × 420 mm (1.72 × 17.32 × 16.54 in)	43.6 × 440 × 420 mm (1.72 × 17.32 × 16.54 in)
AC power module	Rated voltage range: 100 to 240 VAC @ 50/60 Hz	Rated voltage range: 100 to 240 VAC @ 50/60 Hz
System power consumption	86 W to 160 W	86 W to 160 W
Weight (excluding power modules)	5.4 kg (11.90 lb)	5.4 kg (11.90 lb)

**Table 2 AC power module specifications**

Item	Specification
Model	PSR150-A1
Rated input voltage range	100 VAC to 240 VAC @ 50/60 Hz
Rated power capacity	150 W

# Contents

- Appendix B LEDs .....1
- LEDs.....1
- LED description .....2

# Appendix B LEDs

## LEDs

Figure 1 WX3820H LEDs

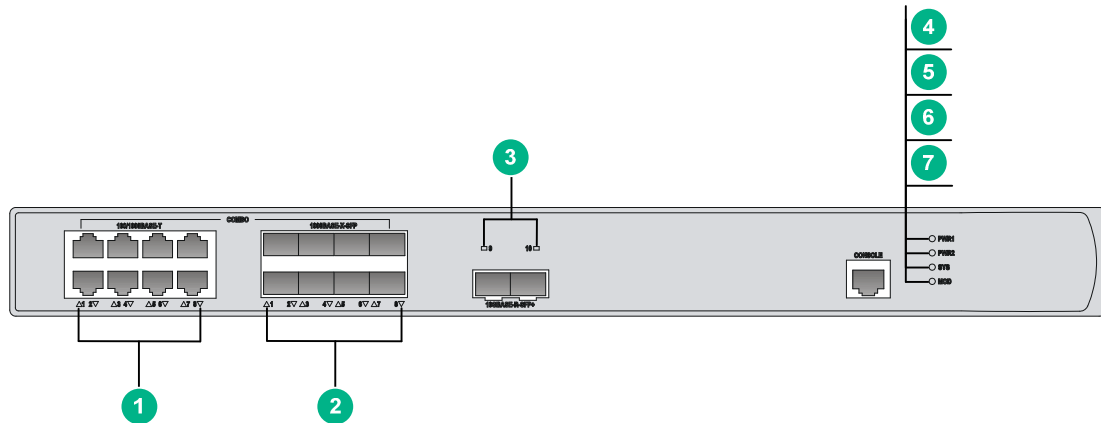

(1) 100/1000BASE-T autosensing Ethernet copper port status LEDs	
(2) 100BASE-FX/1000BASE-X SFP port status LEDs	(3) 10GBASE-R SFP+ port status LEDs
(4) Power module 1 status LED (PWR1)	(5) Power module 2 status LED (PWR2)
(6) System status LED (SYS)	(7) Status LED for the module in the reserved slot (MOD)

Figure 2 WX3840H LEDs

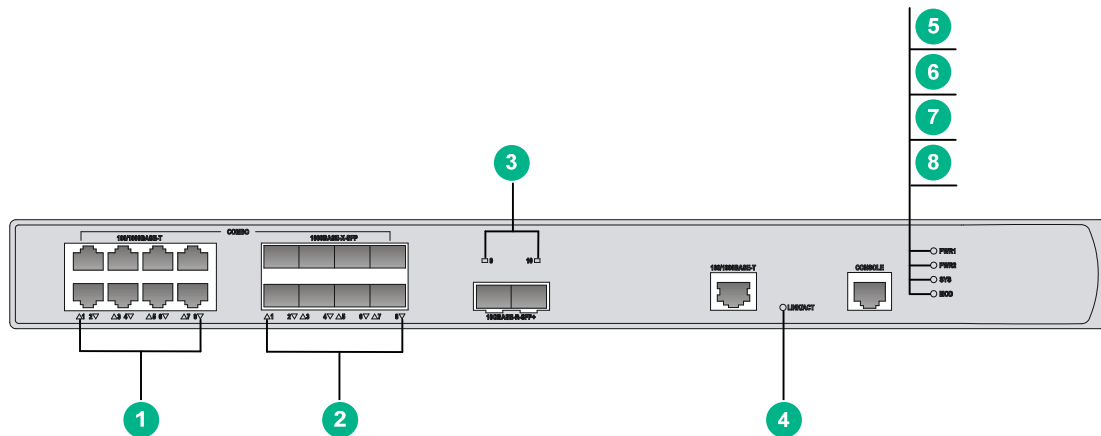

(1) 100/1000BASE-T autosensing Ethernet copper port status LEDs	
(2) 100BASE-FX/1000BASE-X SFP port status LEDs	(3) 10GBASE-R SFP+ port status LEDs
(4) 100/1000BASE-T out-of-band management Ethernet port status LED (LINK/ACT)	
(5) Power module 1 status LED (PWR1)	(6) Power module 2 status LED (PWR2)
(7) System status LED (SYS)	(8) Status LED for the module in the reserved slot (MOD)

# LED description

**Table 1 LED description**

LED	Mark	Status	Description
Power module 1 status LED	PWR1	Steady green	Power module 1 is operating correctly.
		Steady yellow	Power module 1 is faulty.
		Off	No power module is present.
Power module 2 status LED	PWR2	Steady green	Power module 2 is operating correctly.
		Steady yellow	Power module 2 is faulty.
		Off	No power module is present.
System status LED	SYS	Steady green	The system is starting up.
		Flashing green	The system is operating correctly.
		Flashing green	The system is downloading files.
		Steady yellow	The system has failed POST, or a critical fault has been detected.
		Off	No power is present.
Status LED for the module in the reserved slot	MOD	Steady green	The module is present.
		Flashing green	The module is reading or writing data.
		Steady yellow	A failure has occurred on the module.
		Off	No module is present.
100/1000BASE-T out-of-band management Ethernet port status LED	LINK/ACT	Off	No link is present.
		Steady green	A link is present.
		Flashing green	The port is receiving or transmitting data.
100/1000BASE-T autosensing Ethernet copper port status LED	N/A	Steady yellow	A 100 Mbps link is present on the port.
		Flashing yellow	The port is receiving or transmitting data at 100 Mbps.
		Steady green	A 1000 Mbps link is present on the port.
		Flashing green	The port is receiving or transmitting data at 1000 Mbps.
		Off	No link is present on the port.
100BASE-FX/1000BASE-X SFP port status LED	N/A	Steady yellow	A 100 Mbps link is present on the port.
		Flashing yellow	The port is receiving or transmitting data at 100 Mbps.
		Steady green	A 1000 Mbps link is present on the port.
		Flashing green	The port is receiving or transmitting data at 1000 Mbps.
		Off	No link is present on the port.
10GBASE-R SFP+ port status LED	N/A	Steady green	A link is present on the port.
		Flashing green	The port is receiving or transmitting data at 10 Gbps.
		Off	No link is present on the port.

# Contents

- Appendix C Optional transceiver modules .....1
  - Transceiver module, fiber connector, and optical fiber views .....1
  - Transceiver module specifications .....2

# Appendix C Optional transceiver modules

## Transceiver module, fiber connector, and optical fiber views

To connect a fiber port on the device, use an SFP or SFP+ transceiver module and an optical fiber with LC connectors.

**Figure 1 SFP transceiver module**

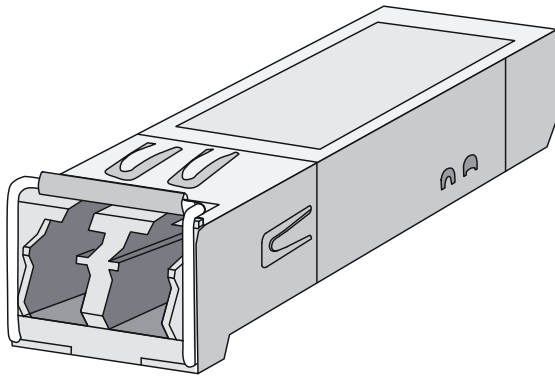

**Figure 2 SFP+ transceiver module**

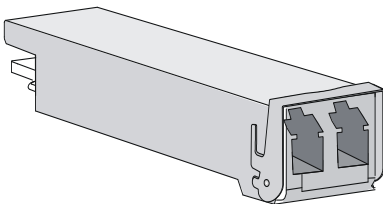

**Figure 3 Optical fiber with LC connectors**

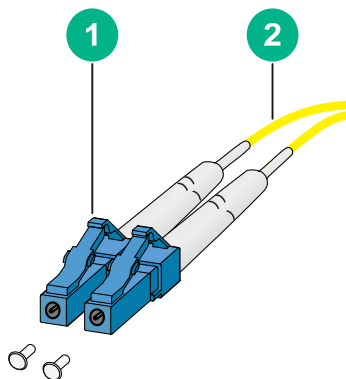

---

(1) LC connector (2) Optical fiber

---

# Transceiver module specifications

The transceiver modules that have **MM** and **SM** in their names support multi-mode optical fibers and single-mode optical fibers, respectively.

The WX3820 and WX3840H access controllers support the following transceiver modules:

- SFP-FE-SX-MM1310-A (see [Table 1](#))
- SFP-FE-LX-SM1310-A (see [Table 2](#))
- SFP-GE-SX-MM850-A (see [Table 3](#))
- SFP-GE-LX-SM1310-A (see [Table 4](#))

**Table 1 SFP-FE-SX-MM1310-A specifications**

Item	Specification
Central wavelength	1310 nm
Transmission distance	2 km (1.24 miles)
Transmission rate	125 Mbps
Connector type	Duplex LC
Fiber mode	MMF
Fiber diameter	50 $\mu$ m
Transmit power	-19 to -14 dBm
Receive sensitivity	$\leq$ -30 dBm
Saturation	$\leq$ -14 dBm

**Table 2 SFP-FE-LX-SM1310-A specifications**

Item	Specification
Central wavelength	1310 nm
Transmission distance	15 km (9.32 miles)
Transmission rate	125 Mbps
Connector type	Duplex LC
Fiber mode	SMF
Fiber diameter	9 $\mu$ m
Transmit power	-15 to -8 dBm
Receive sensitivity	$\leq$ -28 dBm
Saturation	$\leq$ -7 dBm

**Table 3 SFP-GE-SX-MM850-A specifications**

Item	Specification
Central wavelength	850 nm
Transmission distance	550 m (1804.46 ft)
Transmission rate	1250 Mbps
Connector type	Duplex LC



<b>Item</b>	<b>Specification</b>
Fiber mode	MMF
Fiber diameter	50 $\mu\text{m}$
Transmit power	-9.5 to 0 dBm
Receive sensitivity	$\leq -17$ dBm
Saturation	$\leq -3$ dBm

**Table 4 SFP-GE-LX-SM1310-A specifications**

<b>Item</b>	<b>Specification</b>
Central wavelength	1310 nm
Transmission distance	10 km (6.21 miles)
Transmission rate	1250 Mbps
Connector type	Duplex LC
Fiber mode	SMF
Fiber diameter	9 $\mu\text{m}$
Transmit power	-9.5 to -3 dBm
Receive sensitivity	$\leq -20$ dBm
Saturation	$\leq -3$ dBm