



AOC-MH25G-b2S2G



User's Guide

Revision 1.0

The information in this User's Guide has been carefully reviewed and is believed to be accurate. The vendor assumes no responsibility for any inaccuracies that may be contained in this document, and makes no commitment to update or to keep current the information in this user's guide, or to notify any person or organization of the updates. **Please Note: For the most up-to-date version of this user's guide, please see our Website at www.supermicro.com.**

Super Micro Computer, Inc. ("Supermicro") reserves the right to make changes to the product described in this user's guide at any time and without notice. This product, including software and documentation, is the property of Supermicro and/or its licensors, and is supplied only under a license. Any use or reproduction of this product is not allowed, except as expressly permitted by the terms of said license.

IN NO EVENT WILL SUPER MICRO COMPUTER, INC. BE LIABLE FOR DIRECT, INDIRECT, SPECIAL, INCIDENTAL, SPECULATIVE OR CONSEQUENTIAL DAMAGES ARISING FROM THE USE OR INABILITY TO USE THIS PRODUCT OR DOCUMENTATION, EVEN IF ADVISED OF THE POSSIBILITY OF SUCH DAMAGES. IN PARTICULAR, SUPER MICRO COMPUTER, INC. SHALL NOT HAVE LIABILITY FOR ANY HARDWARE, SOFTWARE, OR DATA STORED OR USED WITH THE PRODUCT, INCLUDING THE COSTS OF REPAIRING, REPLACING, INTEGRATING, INSTALLING OR RECOVERING SUCH HARDWARE, SOFTWARE, OR DATA.

Any disputes arising between the manufacturer and the customer shall be governed by the laws of Santa Clara County in the State of California, USA. The State of California, County of Santa Clara shall be the exclusive venue for the resolution of any such disputes. Supermicro's total liability for all claims will not exceed the price paid for the hardware product.

FCC Statement: This equipment has been tested and found to comply with the limits for a Class A digital device pursuant to Part 15 of the FCC Rules. These limits are designed to provide reasonable protection against harmful interference when the equipment is operated in a commercial environment. This equipment generates, uses, and can radiate radio frequency energy and, if not installed and used in accordance with the manufacturer's instruction manual, may cause harmful interference with radio communications. Operation of this equipment in a residential area is likely to cause harmful interference, in which case you will be required to correct the interference at your own expense.

California Best Management Practices Regulations for Perchlorate Materials: This Perchlorate warning applies only to products containing CR (Manganese Dioxide) Lithium coin cells. "Perchlorate Material-special handling may apply. See www.dtsc.ca.gov/hazardouswaste/perchlorate".



WARNING: This product can expose you to chemicals including lead, known to the State of California to cause cancer and birth defects or other reproductive harm. For more information, go to www.P65Warnings.ca.gov.

User's Guide Revision 1.0
Release Date: Aug 30, 2018

Unless you request and receive written permission from Super Micro Computer, Inc., you may not copy any part of this document.

Information in this document is subject to change without notice. Other products and companies referred to herein are trademarks or registered trademarks of their respective companies or mark holders.

Copyright © 2018 by Super Micro Computer, Inc.
All rights reserved.

Printed in the United States of America

Preface

About this User's Guide

This user's guide is written for system integrators, PC technicians, and knowledgeable PC users. It provides information for the installation and use of the AOC-MH25G-b2S2G add-on card.

About this Add-on Card

The Supermicro® AOC-MH25G-b2S2G, which is supported by Broadcom's BMC57414, offers one of the most advanced networking controllers in the market. Featuring dual-port 25GbE SFP connectivity in the SIOM (Super I/O Module) form factor with networking capabilities including XLAN, NVGRE, RoCE, NIC partitioning, this add-on card offers unparalleled performance, functionality, and density. It supports additional two GbE LAN ports, which are based on Intel® i350, and provides NC-SI side-band connections for IPMI remote management. The AOC-MH25G-b2S2G is the most versatile 25GbE controller in the market. It is an excellent choice to enhance network connectivity in data centers and enterprise environments.

An Important Note to the User

All images and layouts shown in this user's guide are based upon the latest PCB revision available at the time of publishing. The card you have received may or may not look exactly the same as the graphics shown in this user's guide.

Returning Merchandise for Service

A receipt or copy of your invoice marked with the date of purchase is required before any warranty service will be rendered. You can obtain service by calling your vendor for a Returned Merchandise Authorization (RMA) number. When returning the add-on-card to the manufacturer, the RMA number should be prominently displayed on the outside of the shipping carton, and the shipping package is mailed prepaid or hand-carried. Shipping and handling charges will be applied for all orders that must be mailed when service is complete. For faster service, You can also request a RMA authorization online (<http://www.supermicro.com>).

This warranty only covers normal consumer use and does not cover damages incurred in shipping or from failure due to the alternation, misuse, abuse or improper maintenance of products.

During the warranty period, contact your distributor first for any product problems.

Conventions Used in the User's Guide

Pay special attention to the following symbols for proper system installation and to prevent damage to the system or injury to yourself:



Note: Additional information given to differentiate between various models or provides information for correct system setup.

Naming Convention



Character	Representation	Options
1st	Product Family	AOC: Add On Card
2nd	Form Factor	S: Standard, P: Proprietary, C: MicroLP, M: Super IO Module (SIOM), MH: SIOM Hybrid
3rd	Product Type/Speed	G: GbE (1Gb/s), TG: 10GbE (10Gb/s), 25G: 25GbE (25Gb/s), 40G: 40GbE (40Gb/s), 50G: 50GbE (50Gb/s), 100G: 100GbE (100Gb/s), IBE: EDR IB (100Gb/s), IBF: FDR IB (56Gb/s), IBQ: QDR IB (40Gb/s), HFI: Host Fabric Interface
4th	Chipset Model (Optional)	N: Niantec (82599), P: Powerville (i350), S: Sageville (X550), F: Fortville (XL710/X710), L: Lewisburg (PCH)
5th	Chipset Manufacturer	i: Intel, m: Mellanox, b: Broadcom
6th	Number of Ports	1: 1 port, 2: 2 ports, 4: 4 ports
7th	Connector Type (Optional)	S: SFP+/SFP28, T: 10GBase-T, Q: QSFP+, C: QSFP28
8th	2nd Controller/Connector Type (Optional)	G: 1x GbE RJ45, 2G: 2x RJ45, S: 1x 10G SFP+, T: 10GBase-T, 2T: 2x 10GBase-T

SMC Networking Add-on Cards

Model	Type	Form Factor	Controller	Connection	Dimension (w/o Brackets) (L x H)	Power (W)
AOC-MGP-i2	GbE	SIOM	Intel® i350 AM2	2 RJ45 (1Gb/port)	3.622" (92mm) x 3.428" (87.08mm)	3.7
AOC-MGP-i4	GbE	SIOM	Intel® i350 AM4	4 RJ45 (1Gb/port)	3.622" (92mm) x 3.428" (87.08mm)	4.4
AOC-MTGN-i2S	10GbE	SIOM	Intel® 82599ES	2 SFP+ (10Gb/port)	3.622" (92mm) x 3.428" (87.08mm)	7.2
AOC-MTG-i4S	10GbE	SIOM	Intel® XL710-BM1	4 SFP+ (10Gb/port)	3.622" (92mm) x 3.428" (87.08mm)	7
AOC-MTG-i2T	10GbE	SIOM	Intel® X550-AT2	2 RJ45 (10GBase-T)	3.622" (92mm) x 3.428" (87.08mm)	13
AOC-MTG-i4T	10GbE	SIOM	2x Intel® X550-AT2	4 RJ45 (10GBase-T)	3.622" (92mm) x 3.428" (87.08mm)	26
AOC-MHIBF-m1Q2G	FDR IB GbE	SIOM	Mellanox® ConnectX-3 Pro Intel® i350	1 QSFP (56Gb/port) 2 RJ45 (1Gb/port)	3.622" (92mm) x 3.428" (87.08mm)	9
AOC-MHIBF-m2Q2G	FDR IB GbE	SIOM	Mellanox® ConnectX-3 Pro Intel® i350	2 QSFP (56Gb/port) 2 RJ45 (1Gb/port)	3.622" (92mm) x 3.428" (87.08mm)	11
AOC-MHIBE-m1CG	EDR IB GbE	SIOM	Mellanox® ConnectX-4 VPI Intel® i210	1 QSFP28 (100Gb/port) 1 RJ45 (1Gb/port)	3.622" (92mm) x 3.428" (87.08mm)	19
AOC-MH25G-b2S2G	25GbE	SIOM	Broadcom® BCM57414 Intel® i350	2 SFP28 (25Gb/port) 2 RJ45 (1Gb/port)	3.622" (92mm) x 3.428" (87.08mm)	9
AOC-MH25G-m2S2T	25GbE	SIOM	Mellanox® ConnectX-4 Lx EN Intel® X550-AT2	2 SFP28 (25Gb/port) 2 RJ45 (10GBase-T)	3.622" (92mm) x 3.428" (87.08mm)	25
AOC-M25G-m4S	25GbE	SIOM	Mellanox® ConnectX-4 Lx EN	4 SFP28 (25Gb/port)	3.622" (92mm) x 3.428" (87.08mm)	20
AOC-M25G-i2S	25GbE	SIOM	Intel® XXV710	2 SFP28 (25Gb/port)	3.622" (92mm) x 3.428" (87.08mm)	11.8
AOC-MHR-i1C	Omni-Path	SIOM	Intel® OP HFI ASIC (Wolf River WFR-B)	1 QSFP28 (100Gb/port)	3.622" (92mm) x 3.428" (87.08mm)	15

Model	Type	Form Factor	Interface	Controller	Connection	Dimension (w/o Brackets) (L x H)	Power (W)
AOC-SGP-42	GbE	Standard LP	PCI-E x4	Intel® I350 AM2	2 RJ45 (1Gb/port)	3.9" (99mm) x 2.73" (69mm)	3.5
AOC-SGP-44	GbE	Standard LP	PCI-E x4	Intel® I350 AM4	4 RJ45 (1Gb/port)	3.9" (99mm) x 2.73" (69mm)	5
AOC-STG-42T	10GbE	Standard LP	PCI-E x8	Intel® X540-AT2	2 RJ45 (10GBase-T)	5.9" (150mm) x 2.73" (69mm)	13
AOC-STGS-11T	10GbE	Standard LP	PCI-E x4	Intel® X550-AT	1 RJ45 (10GBase-T)	5.9" (150mm) x 2.73" (69mm)	9
AOC-STGS-42T	10GbE	Standard LP	PCI-E x4	Intel® X550-AT2	2 RJ45 (10GBase-T)	5.9" (150mm) x 2.73" (69mm)	11
AOC-STG-b2T	10GbE	Standard LP	PCI-E x8	Broadcom® BCM57416	2 RJ45 (10GBase-T)	5.6" (142mm) x 2.73" (69mm)	13.1
AOC-STG-44T	10GbE	Standard LP	PCI-E x8	Intel® XL710-BM1	4 RJ45 (10GBase-T)	5.9" (149mm) x 2.73" (69mm)	15.5
AOC-STGN-1S	10GbE	Standard LP	PCI-E x8	Intel® 82598EN	1 SFP+ (10Gb/port)	4.0" (102mm) x 2.73" (69mm)	10
AOC-STGN-2S	10GbE	Standard LP	PCI-E x8	Intel® 82598ES	2 SFP+ (10Gb/port)	4.0" (102mm) x 2.73" (69mm)	11.2
AOC-STGF-42S	10GbE	Standard LP	PCI-E x8	Intel® X710-BM2	2 SFP+ (10Gb/port)	5.19" (132mm) x 2.73" (69mm)	5.6
AOC-STG-b4S	10GbE	Standard LP	PCI-E x8	Broadcom® BCM57840S	4 SFP+ (10Gb/port)	5.4" (137mm) x 2.73" (69mm)	14
AOC-STG-44S	10GbE	Standard LP	PCI-E x8	Intel® XL710-BM1	4 SFP+ (10Gb/port)	5.9" (150mm) x 2.73" (69mm)	8
AOC-S2SG-m2S	25GbE	Standard LP	PCI-E x8	Mellanox® CX-4 LX	2 SFP28 (25Gb/port)	5.6" (142mm) x 2.713" (69mm)	8.7
AOC-S2SG-b2S	25GbE	Standard LP	PCI-E x8	Broadcom® BCM57414	2 SFP28 (25Gb/port)	5.6" (142mm) x 2.713" (69mm)	5.2
AOC-S2SG-12S	25GbE	Standard LP	PCI-E x8	Intel® XXV710	2 SFP28 (25Gb/port)	6.1" (155mm) x 2.713" (69mm)	7.2
AOC-S40G-11Q	40GbE	Standard LP	PCI-E x8	Intel® XL710-BM1	1 QSFP+ (40Gb/port)	5.9" (150mm) x 2.73" (69mm)	6.5
AOC-S40G-42Q	40GbE	Standard LP	PCI-E x8	Intel® XL710-BM2	2 QSFP+ (40Gb/port)	5.9" (150mm) x 2.73" (69mm)	7
AOC-S100G-m2C	100GbE	Standard LP	PCI-E x16	Mellanox® CX-4 EN	2 QSFP28 (100Gb/port)	6.6" (168mm) x 2.73" (69mm)	16.3
AOC-PTG-11S	10GbE	Proprietary	PCI-E x8	Intel® 82598EN	1 SFP+ (10Gb/port)	10.04" (255mm) x .78" (20mm)	7.5
AOC-IUG-44	GbE	UIO FH	PCI-E x8	Intel® 82571EB	4 RJ45 (1Gb/port)	6.6" (167mm) x 3.9" (98mm)	10
AOC-CGP-42	GbE	MicroLP	PCI-E x4	Intel® I350 AM2	2 RJ45 (1Gb/port)	4.45" (113mm) x 1.54" (39mm)	4
AOC-CG-42	GbE	MicroLP	PCI-E x4	Intel® 82580	2 RJ45 (1Gb/port)	4.45" (113mm) x 1.3" (34mm)	4
AOC-CTG-11S	10GbE	MicroLP	PCI-E x8	Intel® 82598EN	1 SFP+ (10Gb/port)	4.85" (123mm) x 1.54" (39mm)	10
AOC-CTG-42S	10GbE	MicroLP	PCI-E x8	Intel® 82598ES	2 SFP+ (10Gb/port)	4.85" (123mm) x 1.54" (39mm)	11
AOC-CTG-42T	10GbE	MicroLP	PCI-E x8	Intel® X540-AT2	2 RJ45 (10GBase-T)	4.8" (123mm) x 2.75" (77mm)	13
AOC-CTGS-42T	10GbE	MicroLP	PCI-E x4	Intel® X550-AT2	2 RJ45 (10GBase-T)	4.45" (113mm) x 1.54" (39mm)	12
AOC-C25G-m1S	25GbE	MicroLP	PCI-E x8	Mellanox® CX-4 Lx EN	1 SFP28 (25Gb/port)	4.45" (113mm) x 1.54" (39mm)	8.5

Contacting Supermicro

Headquarters

Address: Super Micro Computer, Inc.
980 Rock Ave.
San Jose, CA 95131 U.S.A.

Tel: +1 (408) 503-8000

Fax: +1 (408) 503-8008

Email: marketing@supermicro.com (General Information)
support@supermicro.com (Technical Support)

Website: www.supermicro.com

Europe

Address: Super Micro Computer B.V.
Het Sterrenbeeld 28, 5215 ML
's-Hertogenbosch, The Netherlands

Tel: +31 (0) 73-6400390

Fax: +31 (0) 73-6416525

Email: sales@supermicro.nl (General Information)
support@supermicro.nl (Technical Support)
rma@supermicro.nl (Customer Support)

Asia-Pacific

Address: Super Micro Computer, Inc.
4F, No. 232-1, Liancheng Rd.
Chung-Ho Dist., New Taipei City 235
Taiwan, R.O.C.

Tel: +886-(2) 8226-3990

Fax: +886-(2) 8226-3991

Website: www.supermicro.com.tw

Email: support@supermicro.com.tw (Technical Support)

Tel: +886-(2) 8226-5990 (Technical Support)

Table of Contents

Preface

Chapter 1 Overview

1-1	Overview	1-1
1-2	Key Features	1-1
1-3	Specifications	1-2
1-4	Available SKUs	1-7
1-5	Similar Products	1-7

Chapter 2 Hardware Components

2-1	Add-On Card Image and Layout.....	2-1
2-2	Major Components.....	2-2
2-3	SFP28 Ethernet Connections.....	2-3
2-4	RJ45 LAN Ports and LAN LED indicators	2-4
2-5	DIP Switch.....	2-5

Chapter 3 Installation

3-1	Static-Sensitive Devices.....	3-1
3-2	Before Installation	3-2
3-3	Installing the Add-on Card	3-2
3-4	Installing Drivers on Windows (for Intel® i350-AM2).....	3-5
3-5	Installing Drivers on Linux (for Intel® i350-AM2).....	3-5
3-6	Installing Drivers on FreeBSD (for Intel® i350-AM2).....	3-7
3-7	Installing Drivers (for Broadcom®BCM57414).....	3-10

Chapter 1

Overview

1-1 Overview

Congratulations on purchasing your add-on card from an acknowledged leader in the industry. Supermicro products are designed with the utmost attention to detail to provide you with the highest standards in quality and performance. For product support and updates, please refer to our website at <http://www.supermicro.com/products/nfo/networking.cfm#adapter>.

1-2 Key Features

The key features of this add-on card include the following:

- Super I/O Module (SIOM) Form Factor
- Broadcom® BCM57414 25GbE controller, dual SFP28 connectors
- Intel® i350-AM2 GbE controller, dual RJ45 connectors
- RDMA over Converged Ethernet (RoCE) (25GbE controller only)
- Network Virtualization: VXLAN and NVGRE (25GbE controller only)
- NIC Partitioning (NPAR) (25GbE controller only)
- Broadcom TruFlow (25GbE controller only)
- PCI-SIG SR-IOV
- IEEE1588 Time Sync
- Jumbo Frames support
- NC-SI for IPMI Remote Management (GbE controller only)
- Asset Management Features
- RoHS compliant 6/6 

1-3 Specifications

General

- Super I/O Module (SIOM) Form Factor
- Broadcom® BCM57414 25GbE controller – dual SFP28 connectors with speed up to 25Gbps per port
- Intel® i350-AM2 1GbE GbE controller – dual RJ45 connectors with speed up to 1Gbps per port

Cables Support

- 25GbE SFP28: Direct attach copper cables and Fiber-optic cables (with required optional transceivers)
- GbE RJ45: RJ45 Category-5/5e up to 100m

Power Consumption

- Maximum 9W

Operating Condition

- Operating temperature: 0°C to 55°C (32°F to 131°F)
- Storage temperature: -40°C to 70°C (-40°F to 158°F)
- Storage humidity: 90% non-condensing relative humidity at 35°C

Physical Dimensions

- Card PCB dimensions: 92mm (3.62in) x 87.1mm (3.43in) (WxD)

Supported Platforms

- Supermicro® motherboards with Super I/O Module slot
- Supermicro® server systems with Super I/O Module slot (see SIOM Compatibility Matrix online at http://www.supermicro.com/support/resources/AOC/AOC_Compatibility_SIOM.cfm)



Note: This product is sold only as part of an integrated solution with Supermicro server systems.

25GbE SFP28 Specifications

Networking features

- Jumbo frames
- 802.3x flow control
- Link Aggregation (802.3ad)
- Virtual LANs- 802.1q VLAN tagging
- Configurable flow acceleration
- IEEE 1588 and Time Sync

Stateless Offload Features

- TCP, UDP, IPv4, IPv6 checksum offload
- Large send offload
- Receive segment coalescing
- TCP segmentation offload
- Large receive offload
- Receive Side Scaling (RSS)
- Transmit Side Scaling (TSS)

NIC Partitioning (NPAR)

- 16 Physical functions
- QoS per partition
- Partitioning control via sideband communication
- Up to 64 MAC/VLAN filter per partition
- Per partition statistics support
- Stateless offloads configuration per partition
- VEB/VEPA support

Virtualization Features

- NetQueue, VMQueue, and Multiqueue
- Support for 128 Virtual functions
- VXLAN, NVGRE and Geneve
- Edge Virtual Bridging (EVB)

RDMA over Converged Ethernet (RoCE)

- RoCEv1 and RoCEv2
- Data Center Bridging with RoCE

Flow Processing

- Exact/Wildcard match flow lookup
- VLAN insertion/deletion
- NAT/NAPT
- Mirroring

Data Center Bridging

- Priority-based flow control (PFC; IEEE 802.1Qbb)
- Enhanced transmission selection (ETS; IEEE 802.1Qau)
- Quantized congestion notification (QCN; IEEE 802.1Qau)
- Data center bridging capability eXchange (DCBX; IEEE 802.1Qaz)
- 8 traffic classes per port; fully DCB compliant per 802.1Qbb

Power Savings

- ACPI compliant power management
- PCI Express Active State Power Management (ASPM)
- Ultra low-power mode
- Pass-through Energy Efficient Ethernet (IEEE802.3az-2010)

GbE Specifications

Ethernet Features

- IEEE 802.3 auto-negotiation for speed, duplex, and flow control
- IEEE 802.3x and 802.3z compliant flow control support
- Automatic cross-over detection function (MDI/MDI-X)
- 1Gb/s Ethernet IEEE 802.3, 802.3u, 802.3ab PHY specifications compliant
- IEEE 1588 protocol and 802.1AS implementation

Power Management and Efficiency

- Energy Efficient Ethernet (EEE)
- DMA Coalescing reduces platform power consumption

- Active State Power Management (ASPM) support
- LAN disable function
- MAC Power Management controls
- Low Power Link Up – Link Speed Control

Virtualization Features

- PC-SIG SR-IOV support
- VM to VM packet forwarding (Packet Loopback)
- Flexible port partitioning
- IEEE 802.1q VLAN support
- IEEE 802.1q advanced packet filtering
- Jumbo frames support

Performance Features

- TCP/UDP, IPv4 and IPv6 checksum offloads to improve CPU usage
- Low Latency Interrupts
- Tx TCP segmentation offload (IPv4, IPv6) increases throughput and lowers processor usage
- Receive Side Scaling (RSS) for Windows environment, scalable I/O for intelligent interrupt generation

Management Features

- Preboot eXecution Environment (PXE) support
- iSCSI remote boot support
- NC-SI for remote management

1-4 Available SKUs

SKUs	Part Number	Description
AOC-MH25G-b2S2G	AOC-MH25G-b2S2G	2-port 25 Gigabit & 2-port Gigabit Ethernet Adapter
	BKT-0112L	Swappable bracket for 2U+ chassis
AOC-MH25G-b2S2GM	AOC-MH25G-b2S2GM	2-port 25 Gigabit & 2-port Gigabit Ethernet Adapter
	BKT-0113L	Internal bracket

1-5 Similar Products

Product Part Number	Form Factor	Protocols	Connector Type	Total Ports	Controller
AOC-MGP-i2	SIOM	1GbE	RJ45	2	Intel® i350
AOC-MGP-i4	SIOM	1GbE	RJ45	4	Intel® i350
AOC-MTGN-i2S	SIOM	10GbE	SFP+	2	Intel® 82599
AOC-MTG-i4S	SIOM	10GbE	SFP+	4	Intel® XL710
AOC-MTG-i2T	SIOM	10GbE	RJ45	2	Intel® X550
AOC-MTG-i4T	SIOM	10GbE	RJ45	4	Intel® X550
AOC-MH25G-m2S2T	SIOM	25GbE 10GbE	SFP28	2	Mellanox® ConnectX-4 Lx EN
			RJ45	2	Intel® X550
AOC-MHIBF-m2Q2G	SIOM	InfiniBand FDR GbE	QSFP+	2	Mellanox® ConnectX-3 Pro
			RJ45	2	Intel® i350
AOC-MHIBF-m1Q2G	SIOM	InfiniBand FDR GbE	QSFP+	1	Mellanox® ConnectX-3 Pro
			RJ45	2	Intel® i350
AOC-MHFI-i1C	SIOM	Omni-Path	QSFP28	1	Intel® OPA HFI

Chapter 2

Hardware Components

2-1 Add-On Card Image and Layout

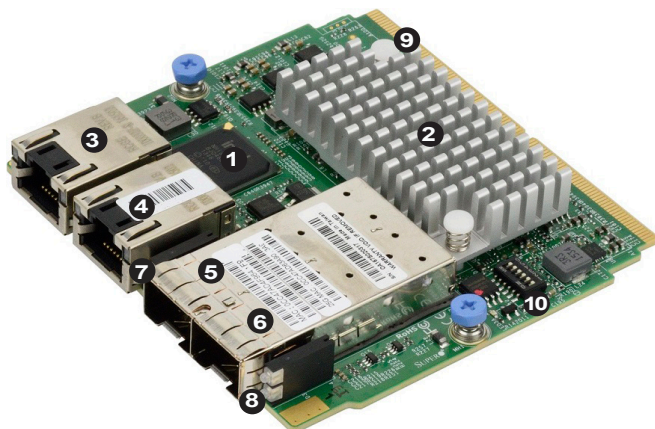

The AOC-MH25G-b2S2G Image

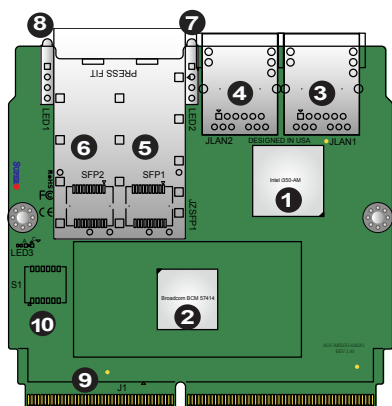

The AOC-MH25G-b2S2G Layout

1. Intel® i350-AM Controller	6. LAN4: SFP28 Port2
2. Broadcom®BCM57414 Controller	7. 25G_LED1: LAN3 Link/Activity LED
3. LAN1: RJ45 Port1	8. 25G_LED2: LAN4 Link/Activity LED
4. LAN2: RJ45 Port2	9. J1: PCI-E Gen2 x4/Gen3 x8
5. LAN3: SFP28 Port1	10. S1: DIP Switch

2-2 Major Components

The following major components are installed on the AOC-MH25G-b2S2G:

1. Intel® i350-AM2 controller
2. Broadcom® BCM57414 controller
3. Dual RJ45 LAN ports
4. Dual SFP28 (Small Form Factor Pluggable) ports
5. Two (2) SFP28 Link/Activity LED indicators
6. DIP switch

2-3 SFP28 Ethernet Connections

SFP28 (LAN3/LAN4) Connectors

Two small form-factor pluggable (SFP28) optical transceiver connectors (LAN3/LAN4) are located on the add-on card. These SFP28 ports provide Ethernet up to 25GbE network connections. See the layout below for the locations.

SFP28 (LAN3/LAN4) Link/Activity LED Indicators

Two LAN Link/Activity LED indicators are located at 25G_LED1 and 25G_LED2 on the add-on card. 25G_LED1 is used for the SFP28 LAN3 connector, and 25G_LED2, for SFP28 LAN4 connector. See the table below for the LED states.

LAN Port Activity LED Indicators Assignment/State	
LED	LAN Port Assigned
25G_LED1	LAN3 Active
25G_LED2	LAN4 Active
Green	SFP28 LAN Port Active

LAN Port Link LEDs LED State	
LED Color	Definition
Amber	10 Gbps
Green	25 Gbps

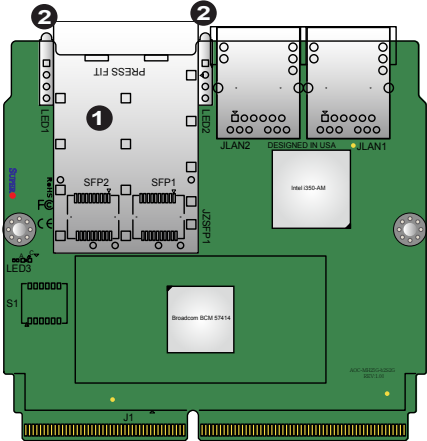

- 1. SFP28 Connectors
- 2. SFP28 Link/Activity LED Indicators

2-4 RJ45 LAN Ports and LAN LED indicators

RJ45 LAN Ports (LAN1/LAN2)

There are two RJ45 LAN ports (LAN1/LAN2) on the AOC-MH25G-b2S2G. These LAN ports support connection speeds of 1Gbps. Use a direct-attach RJ45 type LAN cable. See the layout below for the location.

 **Note:** Please refer to page 1-2 for recommended cables.

RJ45 LAN Port LED Indicators

Each LAN port has two LEDs to indicate speed and data activity. Refer to the table below for LED color and definition.

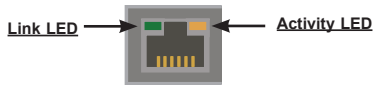

RJ45 LAN Port Link LED (Left) LED State	
LED Color	Definition
Amber	1 Gbps
Green	100 Mbps

RJ45 LAN Port Activity LED (Right) LED State		
LED Color	Status	Definition
Off	Off	No Connection
Green	Solid	Link
Green	Flashing	Active

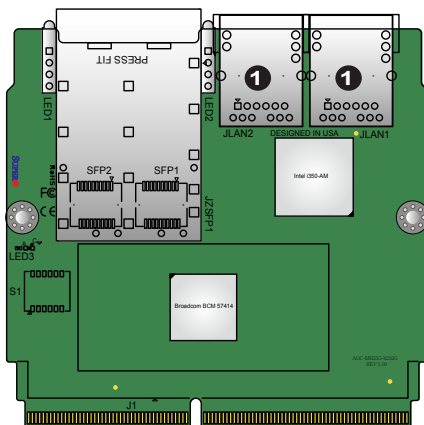

1. RJ45 LAN Ports

2-5 DIP Switch

DIP Switch

The DIP switch at S1 provides SMBUS address selection. You can configure the card with static SMBUS address. Refer to the tables below for address selections. See the layout below for the location.

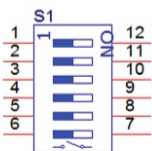

S1-DIP switch for user selection

Switch Position	OFF (default)	ON
1	SMBUS ARP mode	Static SMBUS address mode
2-5	Static SMBUS address selection	
6	Thermal Reading Enable	Thermal Reading Disable

Static SMBUS address selection table by DIP switch S1

SMBUS Address	S1 position #5	S1 position #4	S1 position #3	S1 position #2
30/D0	OFF/ON	OFF	OFF	OFF
32/D2	OFF/ON	OFF	OFF	ON
34/D4	OFF/ON	OFF	ON	OFF
36/D6	OFF/ON	OFF	ON	ON
38/D8	OFF/ON	ON	OFF	OFF
3A/DA	OFF/ON	ON	OFF	ON
3C/DC	OFF/ON	ON	ON	OFF
3E/DE	OFF/ON	ON	ON	ON

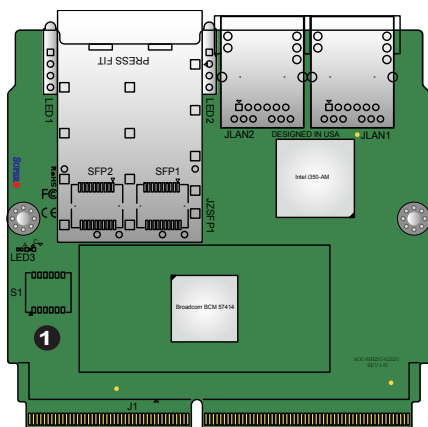

1. DIP Switch

Chapter 3

Installation

3-1 Static-Sensitive Devices

Electrostatic Discharge (ESD) can damage electronic components. To avoid damaging your add-on card, it is important to handle it very carefully. The following measures are generally sufficient to protect your equipment from ESD.

Precautions

- Use a grounded wrist strap designed to prevent static discharge.
- Touch a grounded metal object before removing the add-on card from the antistatic bag.
- Handle the add-on card by its edges only; do not touch its components.
- Put the add-on card back into the antistatic bags when not in use.
- For grounding purposes, make sure that your system chassis provides excellent conductivity between the power supply, the case, the mounting fasteners and the add-on card.

Unpacking

The add-on card is shipped in antistatic packaging to avoid static damage. When unpacking your component or system, make sure you are static protected.



Note: To avoid damaging your components and to ensure proper installation, always connect the power cord last, and always unplug it before adding, removing or changing any hardware components.

3-2 Before Installation

Before you install the add-on card, follow the instructions below.

1. Power down the system.
2. Unplug the power cord.
3. Use industry-standard anti-static equipment such as gloves or a wrist strap and follow the precautions on page 3-1 to avoid damage caused by ESD.
4. Familiarize yourself with the server, motherboard, and/or chassis documentation.
5. Confirm that your operating system includes the latest updates and hotfixes.

3-3 Installing the Add-on Card

Follow the steps below to install the add-on card into your system.

1. Remove the server cover and, if any, set aside any screws for later use.
2. Remove the add-on card slot cover. If the slot cover has a screw, place it aside for later use.
3. Position the add-on card in front of the SIOM slot and gently push in both sides of the card until it slides into the slot.

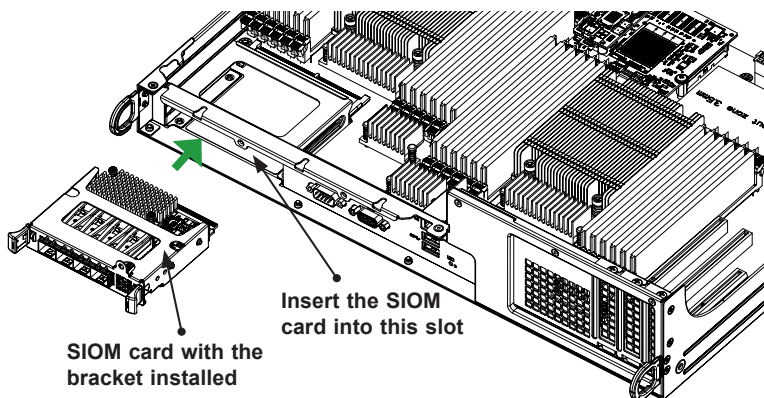

 **Note:** This add-on card does not support hot plug. Please turn off the AC power and remove the power cord from the wall socket before you install or remove the add-on card.

4. Secure the add-on card to the chassis. If required, use the screws that you previously removed.
5. Attach any necessary external cables to the add-on card.
6. Replace the system cover.
7. Plug in the power cord and power up the system.

Follow this step to install the add-on card if your system does not support a swappable bracket. Insert the SIOM card in the motherboard and then install the motherboard in the chassis. An internal bracket comes with the SIOM card 1U in the chassis SKU. It needs to be installed onto the chassis.

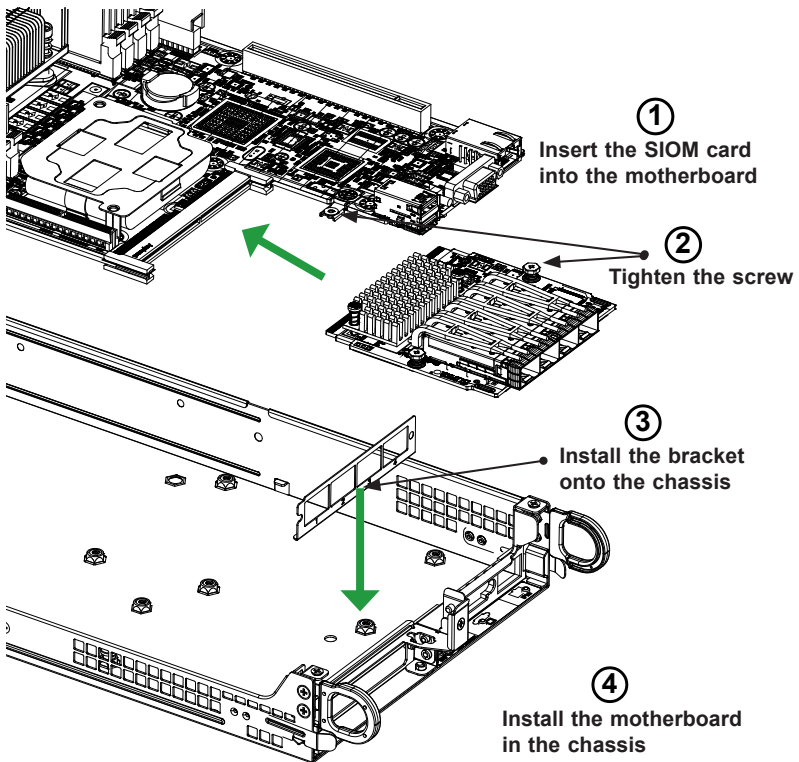

 **Note:** Supermicro recommends that this SIOM card be installed by a system integrator or by the manufacturer.

Follow the steps below to install the add-on card into your system that supports a swappable bracket. The add-on card must be installed in the swappable bracket before it can be installed in the your system

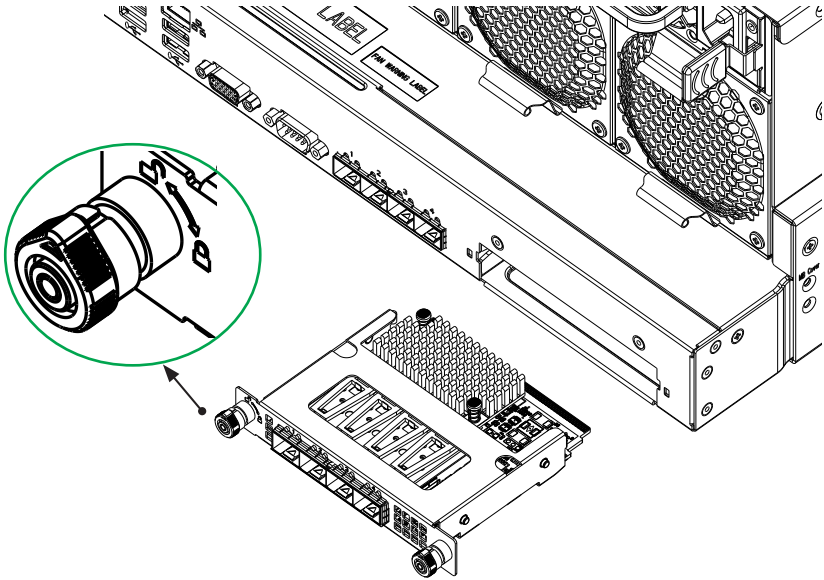

1. Install the add-on card into the swappable bracket.
2. Position the add-on card in front of the SIOM slot and gently push in both sides of the card until it slides into the slot.
3. Once the card is in the slot, push both knobs in and turn to the right to lock the card in the system. The left knob has the unlock/lock symbols next to it. To ensure that the add-on is locked, make sure that the knob position indicator is pointing to the lock symbol.

3-4 Installing Drivers on Windows (for Intel® i350-AM2)

Follow the steps below to install the drivers for Windows. Download the drivers from Intel Download Center or the Supermicro site at https://www.supermicro.com/wftp/Networking_Drivers.

1. Run CDR-NIC.
2. When the SUPERMICRO window appears, click on the computer icon next to the product model.

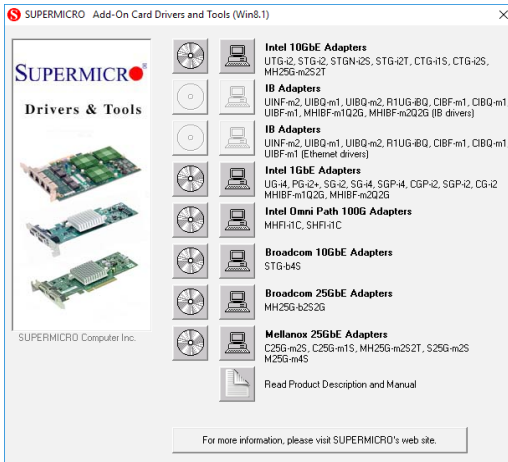

Note: If the *FOUND NEW HARDWARE WIZARD* screen displays on your system, click CANCEL.

3. Click on INSTALL DRIVERS AND SOFTWARE.
4. Follow the prompts to complete the installation.

3-5 Installing Drivers on Linux (for Intel® i350-AM2)

Download the drivers from Intel Download Center or the Supermicro site at https://www.supermicro.com/wftp/Networking_Drivers.

Build a Binary RPM Package

1. Run 'rpmbuild -tb <filename.tar.gz>'
2. Replace <filename.tar.gz> with the specific filename of the driver.



Note: For the build to work properly, the current running kernel **MUST** match the version and configuration of the installed kernel sources. If you have just recompiled the kernel, reboot the system at this time.

Follow the instructions below to build the driver manually.

1. Move the base driver tar file to the directory of your choice. For example:

```
/home/username/ixgbe
```

or

```
/usr/local/src/ixgbe
```

2. Untar/unzip archive, where <x.x.x> is the version number for the driver tar file:

```
tar xzf ixgbe-x.x.x.tar.gz
```

3. Change to the driver src directory, where <x.x.x> is the version number for the driver tar:

```
cd ixgbe-x.x.x/src/
```

4. Compile the driver module:

```
make install
```

The binary will be installed as:

```
/lib/modules/[KERNEL_VERSION]/kernel/drivers/net/ixgbe/ixgbe.[k]o
```

The install locations listed above are the default locations. They may not be correct for certain Linux distributions. For more information, see the `ldistrib.txt` file included in the driver tar.



Note: `IXGBE_NO_LRO` is a compile time flag. The user can enable it at compile time to remove support for LRO from the driver. The flag is used by adding `CFLAGS_EXTRA="-DIXGBE_NO_LRO"` to the make file when it's being compiled.

```
make CFLAGS_EXTRA="-DIXGBE_NO_LRO" install
```

5. Load the module:

For kernel 2.6.x, use the `modprobe` command:

```
modprobe ixgbe <parameter>=<value>
```

For 2.6 kernels, the `insmod` command can be used if the full path to the driver module is specified. For example:

```
insmod /lib/modules/<KERNEL_VERSION>/kernel/drivers/net/
ixgbe/ixgbe.ko
```

In addition, when using 2.6-based kernels, make sure that older `ixgbe` drivers are removed from the kernel before loading the new module. To do this, use:

```
rmmmod ixgbe; modprobe ixgbe
```

6. Assign an IP address to the interface by entering the following, where `x` is the interface number:

```
ifconfig ethx <IP_address> netmask <netmask>
```

7. Verify that the interface works. Enter the following, where `<IP_address>` is the IP address for another machine on the same subnet as the interface that is being tested:

```
ping <IP_address>
```

3-6 Installing Drivers on FreeBSD (for Intel® i350-AM2)

Follow the instructions below to install the drivers for FreeBSD kernel 4.8 or later. In the instructions below, `x.x.x` is the driver version as indicated in the name of the driver tar file.



Note: You must have kernel sources installed in order to compile the driver module.

1. Move the base driver tar file to the directory of your choice. For example, use `/home/username/ixgb` or `/usr/local/src/ixgb`.

2. Untar/unzip the archive:

```
tar xfz ixgb-x.x.x directory
```

3. To install man page:

```
cd ixgb-x.x.x
gzip -c ixgb.4 > /usr/share/man/man4/ixgb.4.gz
```

4. To load the driver onto a running system, perform the following steps:

```
cd ixgb-x.x.x
make
or
cd ixgb-x.x.x/src
make load
```

5. To assign an IP address to the interface, enter the following:

```
ifconfig ixgb<interface_num> <IP_address>
```

6. Verify that the interface works. Enter the following, where <IP_address> is the IP address for another machine on the same subnet as the interface that is being tested:

```
ping <IP_address>
```

7. If you want the driver to load automatically when the system is booted:

```
cd ixgb-x.x.x/src
make load
cp if_ixgb.ko /modules
```

Edit /boot/loader.conf, and add the following line:

```
if_ixgb_load="YES"
```

or

compile the driver into the kernel (see item 8). Edit /etc/rc.conf, and create the appropriate ifconfig_ixgb<interface_num> entry:

```
ifconfig_ixgb<interface_num>=<ifconfig_settings>
```

Example usage:

```
ifconfig_ixgb0="inet 192.168.10.1 netmask 255.255.255.0"
```

8. If you want to compile the driver into the kernel, enter:

```
cd ixgb-x.x.x/src
mkdir /usr/src/sys/dev/ixgb
cp if_ixgb* /usr/src/sys/dev/ixgb
cp ixgb* /usr/src/sys/dev/ixgb
cp Makefile.kernel /usr/src/sys/modules/ixgb/Makefile
```

Edit the `/usr/src/sys/conf/files.i386` file, and add the following line:

```
dev/ixgb/ixgb_hw.c optional ixgb
dev/ixgb/ixgb_ee.c optional ixgb
dev/ixgb/if_ixgb.c optional ixgb
```

Remove the following lines from the `/usr/src/sys/conf/files.i386` file, if they exist:

```
/dev/ixgb/if_ixgb_fx_hw.c optional ixgb
/dev/ixgb/if_ixgb_phy.c optional ixgb
```

Edit the kernel configuration file (i.e., `GENERIC` or `MYKERNEL`) in `/usr/src/sys/i386/conf`, and ensure the following line is present:

```
device ixgb
```

Compile and install the kernel. Reboot the system for the kernel updates to take affect.

3-7 Installing Drivers (for Broadcom®BCM57414)

Use the procedures below to install both drivers and firmware for the AOC-MH25G-b2S2G add-on card for both Linux and Windows.

Linux Drivers

Use the following procedures to install drivers on the Linux operating system. Download the drivers from https://www.supermicro.com/wftp/Networking_Drivers.

Installing 25G Drivers for the Linux Operating System

1. Prerequisites: Install the following:

```
yum -y install libibverbs* infiniband-diags perftest  
qperf librdmacm-utils
```

```
yum -y install groupinstall "InfiniBand Support"
```

2. From the CDR-NIC LAN driver CD or the Supermicro site, go to the following directory: Broadcom > 25G > Linux_Driver.
3. Download the Linux driver package file netxtreme-bnxt_en-<ver>.tar.gz
4. Install the driver by entering the following commands:

```
tar xzvf nextreme-bnxt_en-<ver>.tar.gz  
cd nextreme-bnxt_en-<ver>  
make build  
make install
```

5. You will need to install RoCE library if you want to use RoCE
6. From the CDR-NIC LAN driver CD or the Supermicro site, go to the following directory: Broadcom > 25G > Linux_RoCE_Lib
7. Download libbnxtre-<ver>.tar.gz

8. Install the library by entering the following commands:

```
tar xvzf libbnxtre-<ver>.tar.gz
cd libbnxtre-<ver>.tar.gz
./configure
make
make install
cp bnxtre.driver /etc/libibverbs.d/
echo "/usr/local/lib" >> /etc/ld.so.conf
ldconfig -v
```

Windows Drivers

Use the following procedures to install drivers on the Windows operating system.

Installing 25G Drivers for the Windows Operating System

1. From the CDR-NIC LAN driver CD or the Supermicro site at https://www.supermicro.com/wftp/Networking_Drivers/, go to the following directory: Broad-com > 25G > Windows.
2. Choose the desired Windows driver package folder.
3. Drivers are in .inf format. You can install the driver from Device Manager.