

Lenovo ThinkSystem SD650 V3 Neptune DWC Server Product Guide

The ThinkSystem SD650 V3 Neptune DWC node is the next-generation high-performance server based on the fifth generation Lenovo Neptune™ direct water cooling platform.

With two 5th Gen Intel Xeon Scalable processors or two Intel Max Series processors, the ThinkSystem SD650 V3 server combines the latest Intel processors and Lenovo's market-leading water-cooling solution, which results in extreme performance in an extreme dense packaging, supporting your application from Exascale to Everscale™.

The direct water cooled solution is designed to operate by using warm water, up to 45°C (113°F). Chillers are not needed for most customers, meaning even greater savings and a lower total cost of ownership. The nodes are housed in the upgraded ThinkSystem DW612S enclosure, a 6U rack mount unit that fits in a standard 19-inch rack.

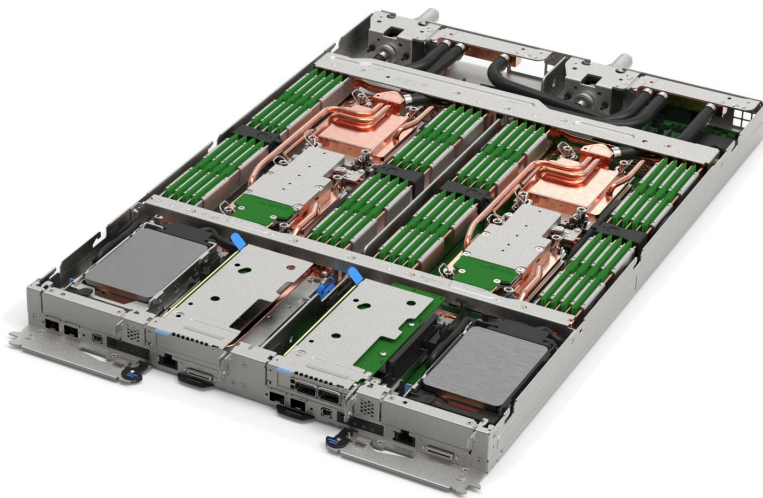

Figure 1. The Lenovo ThinkSystem SD650 V3 server tray with two distinct two-socket nodes

Did you know?

The ThinkSystem SD650 V3 server tray and DW612S enclosure with direct water cooling provide the ultimate in data center cooling efficiencies and performance. The water loop design is bifurcating to balance and parallelize the cooling across all major heat sources in both nodes. This ensures temperature uniformity to avoid thermal jitter as you would observe in serial loops. Combined with the low pressure-drop design, you can use higher water temperatures on the highest performing chips while benefiting from saving energy and cost associated to cold water chillers.

Key features

The Lenovo ThinkSystem SD650 V3 dual-node server tray is designed for High Performance Computing (HPC), large-scale cloud, heavy simulations, and modeling. It implements Lenovo Neptune™ Direct Water Cooling (DWC) technology to optimally support workloads from technical computing, grid deployments, analytics, and is ideally suited for fields such as research, life sciences, energy, simulation, and engineering.

The unique design of ThinkSystem SD650 V3 provides the optimal balance of serviceability, performance, and efficiency. By using a standard rack with the ThinkSystem DW612S enclosure equipped with patented stainless steel drip-less quick connectors, the SD650 V3 provides easy serviceability and extreme density that is well suited for clusters ranging from small enterprises to the world's largest supercomputers.

The Lenovo Neptune™ direct liquid cooling doesn't use risky plastic retrofitting but instead custom-designed copper water loops, so you have peace of mind implementing a platform with liquid cooling at the core of the design.

Compared to other technology, the SD650 V3 direct water cooling:

- Reduces data center energy costs by up to 40%
- Increases system performance by up to 10%
- Delivers up to 100% heat removal efficiency into water (depending on environment)
- Creates a quieter data center with its fan-less design
- Enables data center growth without adding computer room air conditioning

Lenovo's direct water-cooled solutions are factory-integrated and are re-tested at the rack-level to ensure that a rack can be directly deployed at the customer site. This careful and consistent quality testing has been developed as a result of over a decade of experience designing and deploying DWC solutions to the very highest standards.

Scalability and performance

The ThinkSystem SD650 V3 server tray and DW612S enclosure offer the following features to boost performance, improve scalability, and reduce costs:

- Each SD650 V3 node supports two high-performance Intel Xeon Scalable processors, 32x TruDDR5 DIMMs, up to two PCIe 5.0 slots for high-speed I/O, and up to two drive bays, in a half-wide 1U form factor.
- Up to 12x SD650 V3 nodes are installed in 6x trays in the DW612S enclosure, occupying only 6U of rack space. It is a highly dense, scalable, and price-optimized offering.
- Each node supports one or two 5th Gen Intel Xeon Processor Scalable processors
 - Up to 64 cores and 128 threads
 - Core speeds of up to 3.9 GHz
 - TDP ratings of up to 385 W
- Alternatively, each node supports one or two 4th Gen Intel Xeon Processor Scalable processors
 - Up to 60 cores and 120 threads
 - Core speeds of up to 3.7 GHz
 - TDP ratings of up to 350 W
- Alternatively, each node supports one or two Intel Xeon Max Series processors
 - Integrated 64GB High Bandwidth Memory (HBM)
 - Up to 56 cores and 112 threads
 - Core speeds of up to 2.7 GHz
 - TDP ratings of up to 350 W
- Support for DDR5 memory DIMMs to maximize the performance of the memory subsystem. Each node supports the following:
 - Up to 16 DDR5 memory DIMMs, 8 DIMMs per processor
 - 8 memory channels per processor (1 DIMM per channel)
 - Supports 1 DIMM per channel operating at 5600 MHz (5th Gen processors) or 4800 MHz (4th

- Gen processors)
 - Using 128GB 3DS RDIMMs, the server supports up to 2TB of system memory
- Each node supports combinations of PCIe 5.0 x16 slots and SSDs, as follows:
 - One PCIe 5.0 x16 slot and either two 7mm SSDs or two E3.S EDSFF SSDs
 - One PCIe 5.0 x16 slot and one 15mm SSD
 - Two PCIe 5.0 x16 slots without SSDs (M.2 still supported)
- The server is Compute Express Link (CXL) v1.1 Ready. With CXL 1.1 for next-generation workloads, you can reduce compute latency in the data center and lower TCO. CXL is a protocol that runs across the standard PCIe physical layer and can support both standard PCIe devices as well as CXL devices on the same link.
- Drives can be either SATA or high-performance NVMe drives, to maximize I/O performance in terms of throughput, bandwidth, and latency.
- Supports a PCIe 4.0 x4 high-speed M.2 NVMe drive installed in an adapter for convenient operating system boot and internal storage functions.
- The node includes one Gigabit and two 25 Gb Ethernet onboard ports for cost effective networking. High speed networking can be added through the included PCIe slots.
- The node offers PCI Express 5.0 I/O expansion capabilities that doubles the theoretical maximum bandwidth of PCIe 4.0 (32GT/s in each direction for PCIe 5.0, compared to 16 GT/s with PCIe 4.0). A PCIe 5.0 x16 slot provides 128 GB/s bandwidth, enough to support a 400GbE network connection.

Energy efficiency

The direct water cooled solution offers the following energy efficiency features to save energy, reduce operational costs, increase energy availability, and contribute to a green environment:

- Water cooling eliminates power that is drawn by cooling fans in the enclosure and dramatically reduces the required air movement in the server room, which also saves power. In combination with an Energy Aware Runtime environment, savings as much as 40% are possible in the data center due to the reduced need for air conditioning.
- Water chillers may not be required with a direct water cooled solution. Chillers are a major expense for most geographies and can be reduced or even eliminated because the water temperature can now be 45°C instead of 18°C in an air-cooled environment.
- With the new water-cooled power supplies, essentially 100% system heat recovery is possible, depending on water and ambient temperature chosen. At 45°C water temperature and 30°C room temperature it will be typically around 95% through surface radiated heat. Heat energy absorbed may be reused for heating buildings in the winter, or generating cold through Adsorption Chillers, for further operating expense savings.
- The processors and other microelectronics are run at lower temperatures because they are water cooled, which uses less power, and allows for higher performance through Turbo Mode.
- The processors are run at uniform temperatures because they are cooled in parallel loops, which avoid thermal jitter and provides higher and more reliable performance at same power.
- Low-voltage 1.1V DDR5 memory offers energy savings compared to 1.2V DDR4 DIMMs, an approximately 20% decrease in power consumption
- 80 Plus Titanium power supplies ensure energy efficiency.
- There are power monitoring and management capabilities through the System Management Module in the DW612S enclosure.
- Lenovo power/energy meter based on TI INA226 measures DC power for the CPU at higher than 97% accuracy and 100 Hz sampling frequency to the XCC and can be leveraged both in-band and out-of-band using IPMI raw commands.
- Optional Lenovo XClarity Energy Manager provides advanced data center power notification, analysis, and policy-based management to help achieve lower heat output and reduced cooling needs.

- Optional Energy Aware Runtime provides sophisticated power monitoring and energy optimization on a job-level during the application runtime without impacting performance negatively.

Manageability and security

The following powerful systems management features simplify local and remote management of the SD650 V3 server:

- The server includes an XClarity Controller 2 (XCC2) to monitor server availability. Optional upgrade to XCC Platinum to provide remote control (keyboard video mouse) functions, support for the mounting of remote media files, FIPS 140-3 security, enhanced NIST 800-193 support, boot capture, power capping, and other management and security features.
- Lenovo XClarity Administrator offers comprehensive hardware management tools that help to increase uptime, reduce costs, and improve productivity through advanced server management capabilities.
- Lenovo XClarity Provisioning Manager, based in UEFI and accessible from F1 during boot, provides system inventory information, graphical UEFI Setup, platform update function, RAID Setup wizard, operating system installation function, and diagnostic functions.
- Support for Lenovo XClarity Energy Manager which captures real-time power and temperature data from the server and provides automated controls to lower energy costs.
- Support for industry standard management protocols, IPMI 2.0, SNMP 3.0, Redfish REST API, serial console via IPMI
- The SD650 V3 is enabled with Lenovo HPC & AI Software Stack, so, you can support multiple users and scale within a single cluster environment.
- Lenovo HPC & AI Software Stack provides our HPC customers you with a fully tested and supported open-source software stack to enable your administrators and users with for the most effective and environmentally sustainable consumption of Lenovo supercomputing capabilities.
- Our Confluent management system and Lenovo Intelligent Computing Orchestration (LiCO) web portal provides an interface designed to abstract the users from the complexity of HPC cluster orchestration and AI workloads management, making open-source HPC software consumable for every customer.
- LiCO web portal provides workflows for both AI and HPC, and supports multiple AI frameworks, allowing you to leverage a single cluster for diverse workload requirements.
- Integrated Trusted Platform Module (TPM) 2.0 support enables advanced cryptographic functionality, such as digital signatures and remote attestation.
- Supports Secure Boot to ensure only a digitally signed operating system can be used.
- Industry-standard Advanced Encryption Standard (AES) NI support for faster, stronger encryption.
- With the System Management Module (SMM) installed in the enclosure, only one Ethernet connection is needed to provide remote systems management functions for all SD650 V3 servers and the enclosure.
- The SMM management module has two Ethernet ports which allows a single Ethernet connection to be daisy chained across 7 enclosures and 84 servers, thereby significantly reducing the number of Ethernet switch ports needed to manage an entire rack of SD650 V3 servers and DW612S enclosures.
- The DW612S enclosure includes drip sensors that monitor the inlet and outlet manifold quick connect couplers; leaks are reported via the SMM.
- The server supports Lenovo XClarity suite software with Lenovo XClarity Administrator, Lenovo XClarity Provisioning Manager, and XClarity Energy Manager. They are described further in the Software section of this product guide.
- Lenovo HPC & AI Software Stack provides our HPC customers you with a fully tested and supported open-source software stack to enable your administrators and users with for the most effective and environmentally sustainable consumption of Lenovo supercomputing capabilities.
- Our Confluent management system and Lenovo Intelligent Computing Orchestration (LiCO) web portal provides an interface designed to abstract the users from the complexity of HPC cluster orchestration and AI workloads management, making open-source HPC software consumable for every customer.

- LiCO web portal provides workflows for both AI and HPC, and supports multiple AI frameworks, allowing you to leverage a single cluster for diverse workload requirements.

Availability and serviceability

The SD650 V3 node and DW612S enclosure provide the following features to simplify serviceability and increase system uptime:

- Designed to run 24 hours a day, 7 days a week
- Depending on the configuration and node population, the DW612S enclosure supports N+1 power policies for its power supplies, which means greater system uptime.
- All supported power supplies are hot-swappable, including the water-cooled power supplies.
- Toolless cover removal on the trays provides easy access to upgrades and serviceable parts, such as adapters and memory.
- The server uses ECC memory and supports memory RAS features including Single Device Data Correction (SDDC, also known as Chipkill), Patrol/Demand Scrubbing, Bounded Fault, DRAM Address Command Parity with Replay, DRAM Uncorrected ECC Error Retry, On-die ECC, ECC Error Check and Scrub (ECS), and Post Package Repair.
- Proactive Platform Alerts (including PFA and SMART alerts): Processors, voltage regulators, memory, internal storage (HDDs and SSDs, NVMe SSDs, M.2 storage), fans, power supplies, and server ambient and subcomponent temperatures. Alerts can be surfaced through the XClarity Controller to managers such as Lenovo XClarity Administrator and other standards-based management applications. These proactive alerts let you take appropriate actions in advance of possible failure, thereby increasing server uptime and application availability.
- The XCC offers optional remote management capability and can enable remote keyboard, video, and mouse (KVM) control and remote media for the node.
- Built-in diagnostics in UEFI, using Lenovo XClarity Provisioning Manager, speed up troubleshooting tasks to reduce service time.
- Lenovo XClarity Provisioning Manager supports diagnostics and can save service data to a USB key drive or remote CIFS share folder for troubleshooting and reduce service time.
- Auto restart in the event of a momentary loss of AC power (based on power policy setting in the XClarity Controller service processor)
- Virtual reseal is a supported feature of the System Management Module (SMM2) which simulates physically removing the node from A/C power and reconnecting the node to AC power from a remote location.
- There is a three-year customer replaceable unit and onsite limited warranty, with next business day 9x5 coverage. Optional warranty upgrades and extensions are available.
- With water cooling, system fans are not required. This results in significantly reduced noise levels on the data center floor, a significant benefit to personnel having to work on site.

Components and connectors

The front of the tray with two distinct SD650 V3 nodes is shown in the following figure.

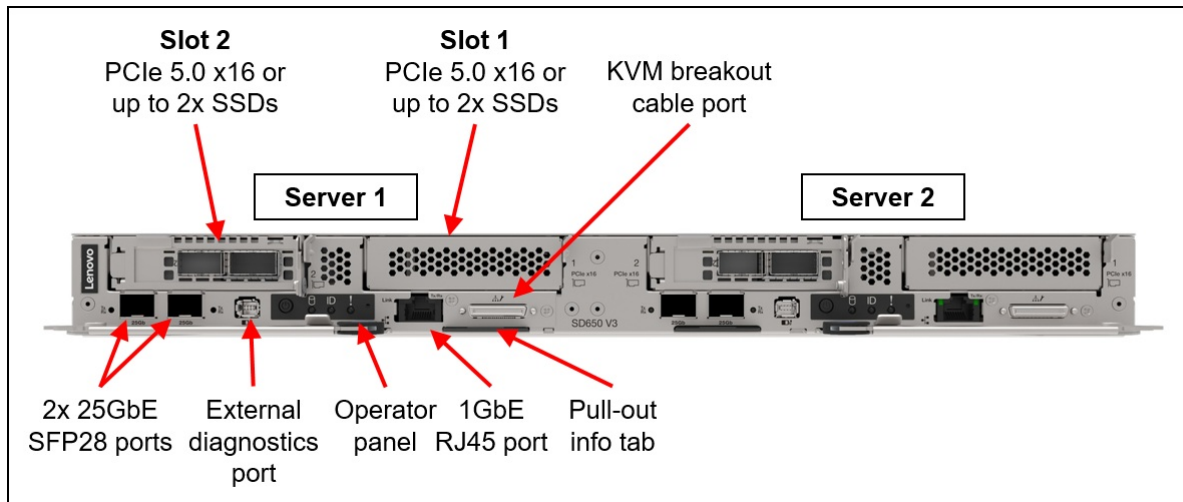

Figure 2. Front view of the tray with two ThinkSystem SD650 V3 nodes

The following figure shows key components internal to the server tray.

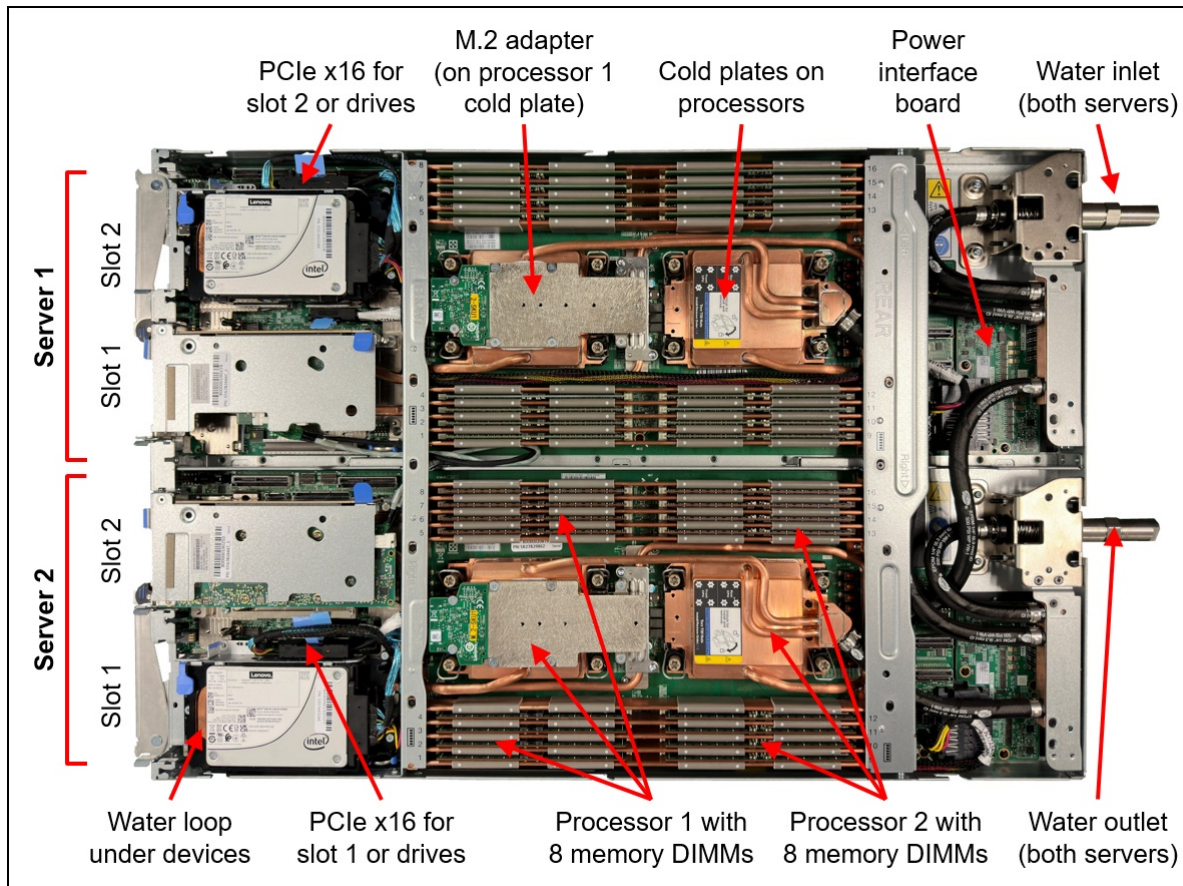

Figure 3. Inside view of the two SD650 V3 nodes in the water-cooled tray

The compute nodes are installed in the ThinkSystem DW612S enclosure, as shown in the following figure.

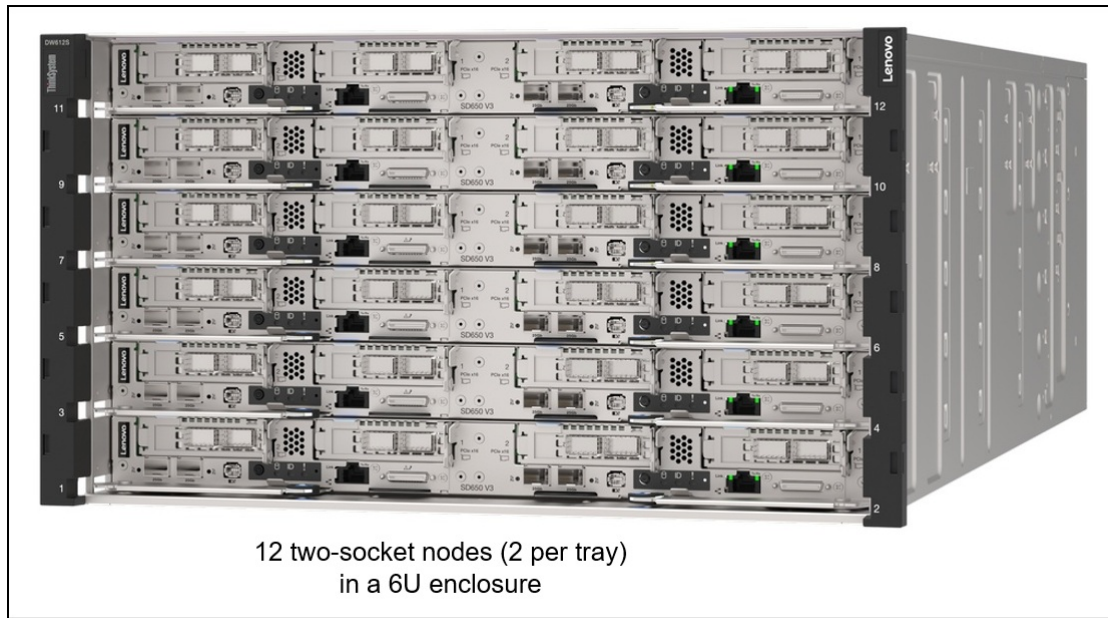

Figure 4. Front view of the DW612S enclosure

The rear of the DW612S enclosure contains the power supplies, cooling water manifolds, and the System Management Module. The following figure shows rear of the enclosure with 6x air-cooled power supplies.

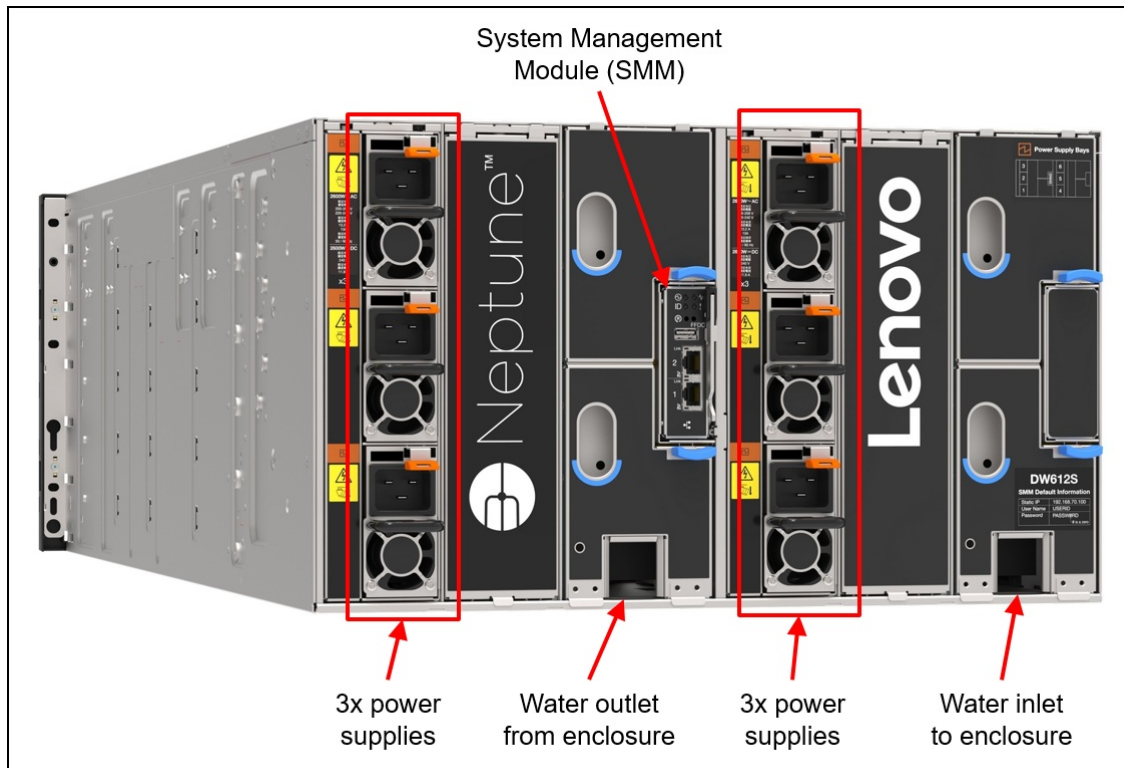

Figure 5. Rear view of the DW612S enclosure with 6 air-cooled power supplies

The also supports water-cooled power supplies for an increased level of heat removal using water. The following figure shows the enclosure with 3 water-cooled power supplies installed.

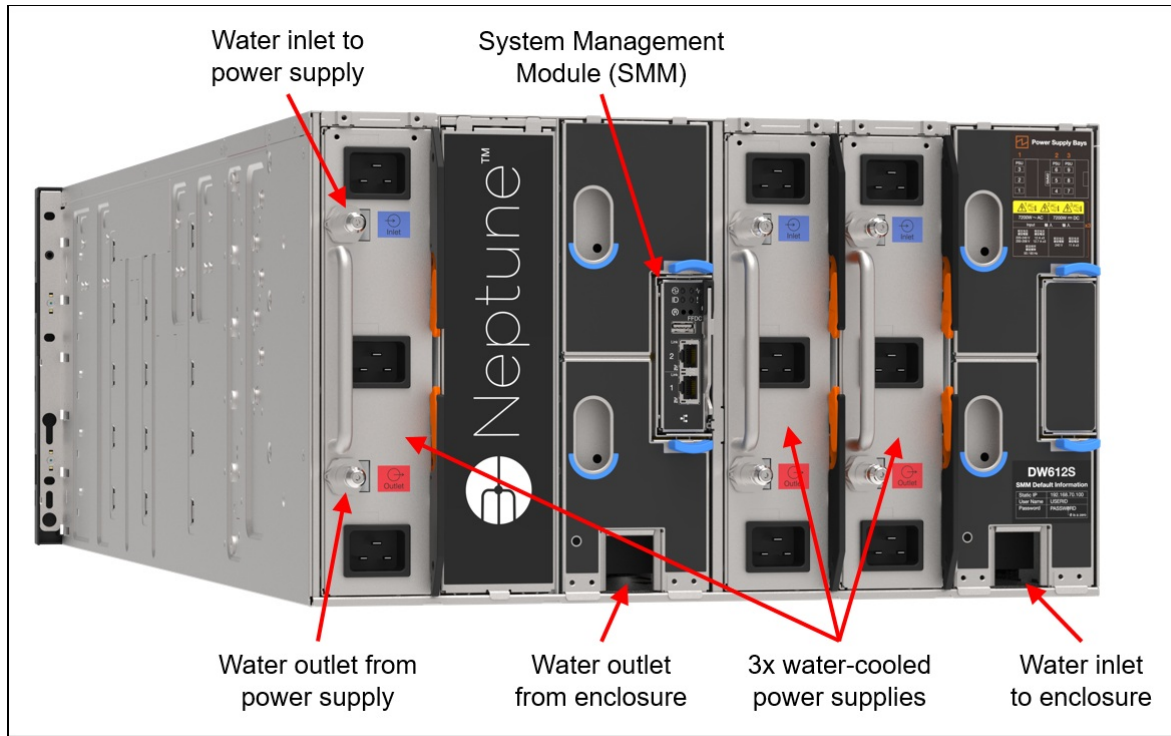

Figure 6. Rear view of the DW612S enclosure with 3 water-cooled power supplies

System architecture

The following figure shows the architectural block diagram of the SD650 V3.

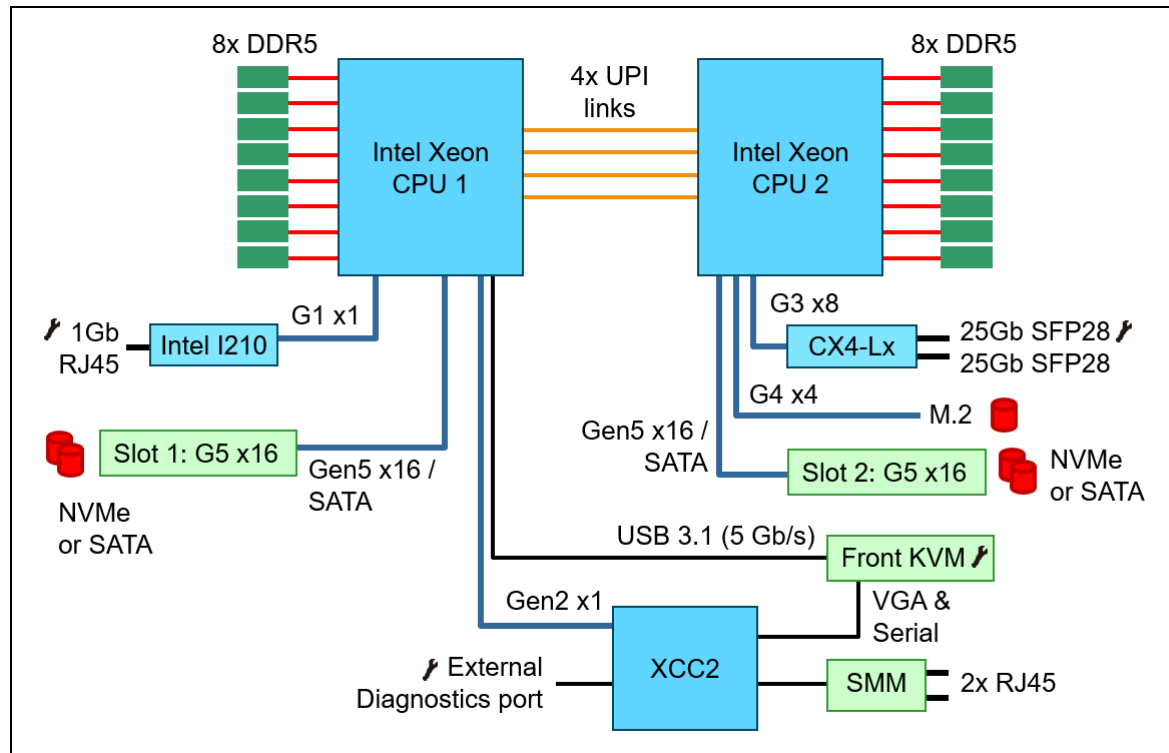

Figure 7. SD650 V3 system architectural block diagram

Standard specifications - SD650 V3 tray

The following table lists the standard specifications of the SD650 V3 server tray.

Table 1. Standard specifications - SD650 V3 tray

Components	Specification
Machine type	7D7M - 3-year warranty
Form factor	Two independent 2-socket nodes mounted on a 1U water-cooled server tray
Enclosure support	<ul style="list-style-type: none"> ThinkSystem DW612S Neptune DWC Enclosure ThinkSystem DW612 Neptune DWC Enclosure
Processor	Two 5th Gen Intel Xeon Scalable processors (formerly codenamed "Emerald Rapids"), or two 4th Gen Intel Xeon Scalable processors (formerly codenamed "Sapphire Rapids"), or two Intel Xeon Max Series processors (formerly codenamed "Sapphire Rapids HBM") per node. Supports processors up to 60 cores, core speeds of up to 3.9 GHz, and TDP ratings of up to 385W. Supports PCIe 5.0 for high performance connectivity to GPUs.
Chipset	Intel C741 "Emmitsburg" chipset, part of the platform codenamed "Eagle Stream"
Memory	16 DIMM slots with two processors (8 DIMM slots per processor) per node. Each processor has 8 memory channels, with 1 DIMM per channel (DPC). Lenovo TruDDR5 RDIMMs, 3DS RDIMMs, and 9x4 RDIMMs are supported, up to 5600 MHz
Persistent memory	Not supported

Components	Specification
Memory maximum	Up to 2TB per node with 16x 128GB 3DS RDIMMs
Memory protection	ECC, SDDC, Patrol/Demand Scrubbing, Bounded Fault, DRAM Address Command Parity with Replay, DRAM Uncorrected ECC Error Retry, On-die ECC, ECC Error Check and Scrub (ECS), Post Package Repair
Disk drive bays	<p>Each node supports one of the following:</p> <ul style="list-style-type: none"> ● Up to 4x E3.S 1T drive bays supporting PCIe 5.0 NVMe drives: <ul style="list-style-type: none"> ○ 4x E3.S drive bays with configurations without a PCIe slots ○ 2x E3.S drive bays with configurations with 1x PCIe slot ○ No drive bays with configuration with 2x PCIe slots (supports an M.2 drive) ● Up to 4x 7mm 2.5-inch drive bays supporting SATA or supporting PCIe 5.0 NVMe drives (but not both): <ul style="list-style-type: none"> ○ 4x 7mm drive bays with configurations without a PCIe slots ○ 2x 7mm drive bays with configurations with 1x PCIe slot ○ No drive bays with configuration with 2x PCIe slots (supports an M.2 drive) ● Up to 2x 15mm 2.5-inch drive bay supporting a PCIe 5.0 NVMe drive <ul style="list-style-type: none"> ○ 2x 15mm drive bays with configurations without a PCIe slots ○ 1x 15mm drive bay with configurations with 1x PCIe slot ○ No drive bays with configuration with 2x PCIe slots (supports an M.2 drive) <p>Each node also supports one high-speed M.2 NVMe SSD with a PCIe 4.0 x4 connection, installed on an M.2 adapter mounted on top of the front processor</p> <p>Note: Configurations with 2x PCIe slots only support the M.2 drive for internal storage</p>
Maximum internal storage	<ul style="list-style-type: none"> ● E3.S trayless drives <ul style="list-style-type: none"> ○ 61.44TB using 4x 15.36TB E3.S NVMe SSDs ● 7mm trayless drives <ul style="list-style-type: none"> ○ 30.72TB using 4x 7.68TB 7mm SATA SSDs ○ 15.36TB using 4x 3.84TB 7mm NVMe SSDs ● 15mm trayless drives <ul style="list-style-type: none"> ○ 7.68TB using 2x 3.84TB 15mm NVMe SSDs
Storage controllers	<ul style="list-style-type: none"> ● 2x Onboard SATA ports (RAID using Intel VROC) ● 2x Onboard NVMe ports (RAID using Intel VROC)
Optical drive bays	No internal bays; use an external USB drive.
Network interfaces	Each node: 2x 25 Gb Ethernet SFP28 onboard connectors based on Mellanox ConnectX-4 Lx controller (support 10/25Gb), 1x 1 Gb Ethernet RJ45 onboard connector based on Intel I210 controller. Onboard 1Gb port and 25Gb port 1 can optionally be shared with the XClarity Controller 2 (XCC) management processor for Wake-on-LAN and NC-SI support.
PCIe slots	Each node: 1x or 2x PCIe 5.0 x16 slots with low profile form factor (each slot is mutually exclusive with one drive bay)
GPUs	No support. Intel Xeon Max Series GPUs is supported on the SD650-I V3 node.
Ports	External diagnostics port, console connector (for a breakout cable that provides one VGA port, one USB 3.1 (5 Gb/s) port and one DB9 serial port for local connectivity). Additional ports provided by the enclosure as described in the Enclosure specifications section.
Video	Embedded video graphics with 16 MB memory with 2D hardware accelerator, integrated into the XClarity Controller. Maximum resolution is 1920x1200 32bpp at 60Hz.
Security features	Power-on password, administrator's password, Trusted Platform Module (TPM), supporting TPM 2.0. In China only, optional Nationz TPM 2.0 plug-in module (support is planned).

Components	Specification
Systems management	Operator panel with status LEDs. Optional External Diagnostics Handset with LCD display. XClarity Controller 2 (XCC2) embedded management based on the ASPEED AST2600 baseboard management controller (BMC), XClarity Administrator centralized infrastructure delivery, XClarity Integrator plugins, and XClarity Energy Manager centralized server power management. Optional XCC Platinum to enable remote control functions and other features. Lenovo power/energy meter based on TI INA226 for 100Hz power measurements with >97% accuracy. System Management Module (SMM2) in the DW612S enclosure provides additional systems management functions.
Operating systems supported	Red Hat Enterprise Linux, SUSE Linux Enterprise Server, and Ubuntu are Supported & Certified. Rocky Linux and AlmaLinux are Tested. See the Operating system support section for details and specific versions.
Limited warranty	Three-year customer-replaceable unit and onsite limited warranty with 9x5 next business day (NBD).
Service and support	Optional service upgrades are available through Lenovo Services: 4-hour or 2-hour response time, 6-hour fix time, 1-year or 2-year warranty extension, software support for Lenovo hardware and some third-party applications.
Dimensions	Width: 438 mm (17.2 inches), height: 41 mm (1.6 inches), depth: 693 mm (27.3 inches)
Weight	20.7 kg (45.6 lb)

Standard specifications - DW612S enclosure

The ThinkSystem DW612S enclosure provides shared high-efficiency power supplies. The SD650 V3 servers connect to the midplane of the DW612S enclosure. This midplane connection is for power and control only; the midplane does not provide any I/O connectivity.

The following table lists the standard specifications of the enclosure.

Table 2. Standard specifications: ThinkSystem DW612S enclosure

Components	Specification
Machine type	7D1L - 3-year warranty
Form factor	6U rack-mounted enclosure.
Maximum number of SD650 V3 nodes supported	Up to 12x nodes per enclosure in 6x SD650 V3 server trays (2 nodes per tray).
Node support	The DW612S supports all ThinkSystem V3 and V2 water-cooled systems (systems can coexist in the same DW612S enclosure). When mixing, install in the following order, from the bottom up: SD665-N V3, SD650-N V3, SD665 V3, SD650-I V3, SD650-N V2, SD650 V3, SD650 V2
Enclosures per rack	Up to six DW612S enclosures per 42U rack and up to seven DW612S enclosures per 48U rack.
Midplane	Passive midplane provides connections to the nodes in the front to the power supplies and fans at the rear. Provides signals to control fan speed, power consumption, and node throttling as needed.

Components	Specification
System Management Module (SMM)	<p>The hot-swappable System Management Module (SMM2) is the management device for the enclosure. Provides integrated systems management functions and controls the power and cooling features of the enclosure. Provides remote browser and CLI-based user interfaces for remote access via the dedicated Gigabit Ethernet port. Remote access is to both the management functions of the enclosure as well as the XClarity Controller (XCC) in each node.</p> <p>The SMM has two Ethernet ports which enables a single incoming Ethernet connection to be daisy chained across 7 enclosures and 84 nodes, thereby significantly reducing the number of Ethernet switch ports needed to manage an entire rack of SD650 V3 nodes and enclosures.</p>
Ports	Two RJ45 port on the rear of the enclosure for 10/100/1000 Ethernet connectivity to the SMM for power and cooling management.
I/O architecture	None integrated. Use top-of-rack networking and storage switches.
Power supplies	6x or 9x air-cooled hot-swap power supplies, or 2x or 3x water-cooled hot-swap power supplies, depending on the power requirements of the installed server node trays. Power supplies installed at the rear of the enclosure. Single power domain supplies power to all nodes. Optional redundancy (N+1 or N+N) and oversubscription, depending on configuration and node population. Each power supply has an integrated fan. 80 PLUS Titanium or Platinum certified depending on the power supply. Built-in overload and surge protection.
Cooling	Direct water cooling supplied by water manifolds connected from the rear of the enclosure.
System LEDs	SMM has four LEDs: system error, identification, status, and system power. Each power supply has AC, DC, and error LEDs. Nodes have more LEDs.
Systems management	Browser-based enclosure management through an Ethernet port on the SMM at the rear of the enclosure. Integrated Ethernet switch provides direct access to the XClarity Controller (XCC) embedded management of the installed nodes. Nodes provide more management features.
Temperature	<ul style="list-style-type: none"> • Operating water temperature: <ul style="list-style-type: none"> ◦ 2°C to 50°C (35.6°F to 122°F) (ASHRAE W45 compliant) • Operating air temperature: <ul style="list-style-type: none"> ◦ 10°C - 35°C (50°F - 95°F) (ASHRAE A2 compliant) <p>See Operating Environment for more information.</p>
Electrical power	200 V - 240 V ac input (nominal), 50 or 60 Hz
Power cords	One C19 AC power cord for each air-cooled power supply Three C19 AC power cords for each water-cooled power supply
Limited warranty	Three-year customer-replaceable unit and onsite limited warranty with 9x5/NBD.
Dimensions	Width: 447 mm (17.6 in.), height: 264 mm (10.4 in.), depth: 933 mm (36.7 in.). See Physical and electrical specifications for details.
Weight	<ul style="list-style-type: none"> • Empty enclosure (with midplane and cables): 24.3 kg (53.5 lb) • Fully configured enclosure with 9x air-cooled power supplies and 6x SD650 V3 server trays: 182.9 kg (403 lb) (without water manifold) • Fully configured enclosure with 3x water-cooled power supplies and 6x SD650 V3 server trays: 188.7 kg (416 lb) (without water manifold)

Models

There are no standard SD650 V3 models; all servers must be configured by using the configure-to-order (CTO) process with the Lenovo Data Center Solution Configurator (DCSC) or the Lenovo Cluster Solutions configurator (x-config). The ThinkSystem SD650 V3 machine type is 7D7M.

The following table lists the base CTO model and base feature code

Table 3. Base CTO model

Machine Type/Model	Description	Base
7D7MCTOLWW	ThinkSystem SD650 V3 Neptune DWC Tray (3-Year Warranty)	BKSG

The following table lists the base feature codes.

Table 4. Base feature codes

Feature code	Description
BKSG	ThinkSystem SD650 V3 Dual Node Tray Base
BRMG	ThinkSystem SD650 V3 Dual Node Tray Base Special Edition*

* Only available in the following markets: JP,AU,NZ,ID,MY,PH,SG,TH,VN,HK,KR,TW,IN,CA,US

Enclosure models

There are no standard models of the DW612S enclosure. All enclosures must be configured by using the CTO process. The machine type is 7D1L.

The following table lists the base CTO model and base feature code

Table 5. Base CTO model

Machine Type/Model	Description	Feature code
7D1LCTO2WW	ThinkSystem DW612S Neptune DWC Enclosure (3-Year Warranty)	BMCA

Manifold assembly

The manifold provides the water supply and return to the DW612S Enclosure. It can be connected through the Eaton Ball Valves (Stainless steel V2A, Type FD83-2046-16-16) to a water loop in the data center that is connected to a centralized coolant distribution unit (CDU) or be ordered with an in-rack CDU.

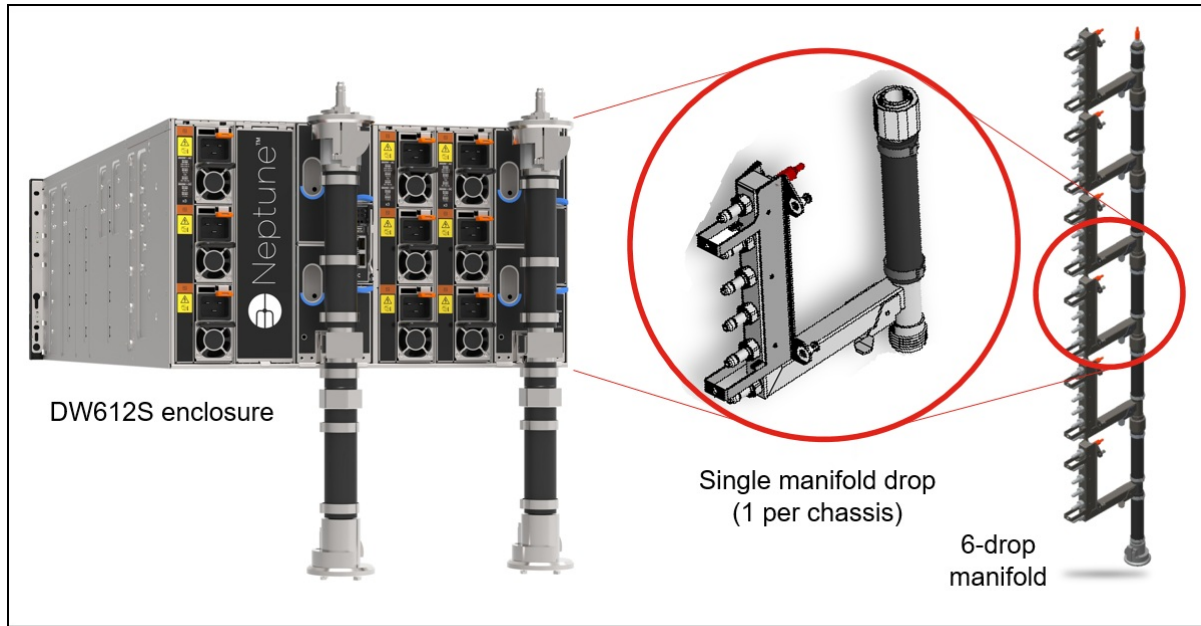

Figure 8. DW612S enclosure and manifold assembly

The manifold is ordered using the CTO process in the configurators using machine type 5469. The following table lists the base CTO model.

Table 6. Base CTO model

Machine Type/Model	Description
5469HC1	Lenovo Neptune DWC Node Manifold

The following table lists the base feature code for CTO configurations when connecting to a data center level water distribution. Select the correct feature code based on the number of enclosures installed in the rack. The feature code for the water-cooled power supplies (PSU) will be auto-derived when you select the PSUs in the configuration and is only supported with 6 Enclosures.

Table 7. Base feature code for CTO models

Feature code	Description
Water manifolds for DW612S enclosure with fixed length hose connection	
A5MN	Lenovo Neptune DWC Manifold Assembly for 1 Enclosure w/ 1.3m hose
A5N7	Lenovo Neptune DWC Manifold Assembly for 2 Enclosures w/ 1.3m hose
A5N8	Lenovo Neptune DWC Manifold Assembly for 3 Enclosures w/ 1.3m hose
A5N9	Lenovo Neptune DWC Manifold Assembly for 4 Enclosures w/ 1.3m hose
BEZX	Lenovo Neptune DWC Manifold Assembly for 5 Enclosures w/ 2.3m hose
BEZW	Lenovo Neptune DWC Manifold Assembly for 6 Enclosures w/ 2.3m hose
BJAK	Lenovo Neptune DWC Manifold Assembly for 7 Enclosures w/ 2.3m hose
Additional water manifold for water-cooled power supplies	
BN0S	Neptune DWC Manifold Assembly for water-cooled Power Supplies

The following table lists the base feature code for CTO configurations when connecting to the in-rack CDU.

Table 8. Base feature code for CTO models

Feature code	Description
Water manifolds for DW612S enclosure with configurable hose connection for use with in-rack CDU	
BRGP	Neptune DWC Manifold Assembly for 1 Enclosure
BRGN	Neptune DWC Manifold Assembly for 2 Enclosure
BY38	Neptune DWC Manifold Assembly for 3 Enclosure
BY39	Neptune DWC Manifold Assembly for 4 Enclosure
BRGM	Neptune DWC Manifold Assembly for 5 Enclosure
BRGL	Neptune DWC Manifold Assembly for 6 Enclosure
Additional water manifold for water-cooled power supplies for use with in-rack CDU	
BRGQ	Neptune DWC Manifold Assembly for water-cooled Power Supplies with in-rack CDU

To support the onsite setup for the direct water-cooled solution, a Commissioning Kit is available providing flow meter, bleed hose, pressure gauge and vent valve to Lenovo partners and customers.

Table 9. Commissioning Kit

Feature code	Description
4XF7A84654	Neptune DWC Manifold Commissioning Kit

For additional information, see the [Cooling](#) section.

In-rack CDU assembly

The RM100 In-Rack Coolant Distribution Unit (CDU) can provide 100kW cooling capacity within the rack cabinet. It is designed as a 4U high rack device installed at the bottom of the rack. The CDU is supported in the 42U and 48U Heavy Duty Rack Cabinets.

Rack support with the DW612S enclosure is as follows:

- 42U rack cabinet: In-Rack CDU with 5 enclosures; no support for water-cooled power supplies
- 48U rack cabinet: In-Rack CDU with 6 enclosures; supports water-cooled power supplies

For information about the 42U and 48U Heavy Duty Rack Cabinets, see the product guide:

<https://lenovopress.lenovo.com/lp1498-lenovo-heavy-duty-rack-cabinets>

The following figure shows the RM100 CDU.



Figure 9. RM100 In-Rack Coolant Distribution Unit

The CDU can be ordered using the CTO process in the configurators using machine type 7DBL. The following table lists the base CTO model and base feature code.

Table 10. Ordering information

CTO model	Base feature	Description
7DBLCTOLWW	BRL4	Lenovo Neptune DWC RM100 In-Rack CDU

For details and exact specification of the CDU, see the In-Rack CDU Operation & Maintenance Guide: https://pubs.lenovo.com/hdc_rackcabinet/rm100_user_guide.pdf

Professional Services: The factory integration of the In-Rack CDU requires Lenovo Professional Services review and approval for warranty and associated extended services. Before ordering CDU and manifold, contact the Lenovo Professional Services team (CDUsupport@lenovo.com).

The following table lists additional feature codes for CTO configurations. They will be auto-derived when you select the in-Rack CDU for the configuration.

Table 11. Base feature code for CTO models

Feature code	Description	Purpose
BRM4	Neptune DWC In-Rack CDU Connection Assembly for DWC Manifold	Assembly to connect in-rack CDUs to Enclosure and Power Supply Manifolds
BRM3	Neptune DWC In-Rack CDU 2.3m Primary Loop Connection Hose	Hose to connect in-rack CDU to the primary datacenter waterloop
BRL3	Neptune DWC In-Rack CDU Filler Kit	Hose to connect to the in-rack CDU for easy filling with water

Processors

The SD650 V3 node supports two processors as follows:

- Two 5th Gen Intel Xeon Scalable processors (formerly codenamed "Emerald Rapids")
- Two 4th Gen Intel Xeon Scalable processors (formerly codenamed "Sapphire Rapids")
- Two Intel Xeon Max Series processors (formerly codenamed "Sapphire Rapids HBM")

Note: A configuration of one processor is not supported.

Topics in this section:

- [Processor options](#)
- [Processor features](#)
- [Intel On Demand feature licensing](#)
- [UEFI operating modes](#)

Processor options

All supported processors have the following characteristics:

- 8 DDR5 memory channels at 1 DIMM per channel
- Up to 4 UPI links between processors at up to 20 GT/s
- 80 PCIe 5.0 I/O lanes

The following table lists the 5th Gen processors that are currently supported by the SD650 V3.

Table 12. 5th Gen Intel Xeon Processor support

Part number	Feature code	SKU	Description	Quantity supported
5th Gen Intel Xeon Scalable processors				
CTO only	BYVX	6526Y	Intel Xeon Gold 6526Y 16C 195W 2.8GHz Processor	2
CTO only	BYW0	6534	Intel Xeon Gold 6534 8C 195W 3.9GHz Processor	2
CTO only	BYVY	6542Y	Intel Xeon Gold 6542Y 24C 250W 2.9GHz Processor	2
CTO only	BYW1	6544Y	Intel Xeon Gold 6544Y 16C 270W 3.6GHz Processor	2
CTO only	BYVZ	6548Y+	Intel Xeon Gold 6548Y+ 32C 250W 2.5GHz Processor	2
CTO only	BYVV	6558Q	Intel Xeon Gold 6558Q 32C 350W 3.2GHz Processor	2
CTO only	BYW5	8558	Intel Xeon Platinum 8558 48C 330W 2.1GHz Processor	2
CTO only	BYW2	8562Y+	Intel Xeon Platinum 8562Y+ 32C 300W 2.8GHz Processor	2
CTO only	BYWF	8568Y+	Intel Xeon Platinum 8568Y+ 48C 350W 2.3GHz Processor	2
CTO only	BYWG	8570	Intel Xeon Platinum 8570 56C 350W 2.1GHz Processor	2
CTO only	BYWH	8580	Intel Xeon Platinum 8580 60C 350W 2.0GHz Processor	2
CTO only	BYWJ	8592+	Intel Xeon Platinum 8592+ 64C 350W 1.9GHz Processor	2
CTO only	BYXG	8593Q	Intel Xeon Platinum 8593Q 64C 385W 2.2GHz Processor	2

The following table lists the 4th Gen processors that are currently supported by the SD650 V3.

Table 13. 4th Gen Intel Xeon Processor support

Part number	Feature code	SKU	Description	Maximum quantity
4th Gen Intel Xeon Scalable processors				
CTO only	BPQF	6426Y	Intel Xeon Gold 6426Y 16C 185W 2.5GHz Processor	2
CTO only	BPQC	6434	Intel Xeon Gold 6434 8C 195W 3.7GHz Processor	2
CTO only	BPQE	6442Y	Intel Xeon Gold 6442Y 24C 225W 2.6GHz Processor	2
CTO only	BPQB	6444Y	Intel Xeon Gold 6444Y 16C 270W 3.6GHz Processor	2
CTO only	BPQD	6448Y	Intel Xeon Gold 6448Y 32C 225W 2.1GHz Processor	2
CTO only	BPQG	6458Q	Intel Xeon Gold 6458Q 32C 350W 3.1GHz Processor	2
CTO only	BPPT	8458P	Intel Xeon Platinum 8458P 44C 350W 2.7GHz Processor	2
CTO only	BPPQ	8460Y+	Intel Xeon Platinum 8460Y+ 40C 300W 2.0GHz Processor	2
CTO only	BPQA	8462Y+	Intel Xeon Platinum 8462Y+ 32C 300W 2.8GHz Processor	2
CTO only	BPPU	8468	Intel Xeon Platinum 8468 48C 350W 2.1GHz Processor	2
CTO only	BPPP	8468V	Intel Xeon Platinum 8468V 48C 330W 2.4GHz Processor	2
CTO only	BN0N	8470	Intel Xeon Platinum 8470 52C 350W 2.0GHz Processor	2
CTO only	BN0P	8470Q	Intel Xeon Platinum 8470Q 52C 350W 2.1GHz Processor	2
CTO only	BN0M	8480+	Intel Xeon Platinum 8480+ 56C 350W 2.0GHz Processor	2
CTO only	BPPS	8490H	Intel Xeon Platinum 8490H 60C 350W 1.9GHz Processor	2

† The 8480CL is a special-order processor without virtualization features that is best suited for HPC workloads. Please contact your Lenovo sales rep for more information.

Configuration notes:

- Single-processor configurations are not supported

Intel Xeon CPU Max Series processors

The SD650 V3 server also supports Intel Xeon CPU Max Series processors which include 64GB of integrated High Bandwidth Memory (HBM2e) for a total of 128GB of memory. Intel Xeon Max processors support three different operating memory modes, configured via a setting in UEFI. You can specify, at time of order, which HBM mode you wish to enable, using the feature codes in the following table.

Table 14. HBM mode feature codes

Feature code	Description	Purpose
BV8P	Intel Xeon CPU Max – HBM Only mode	HBM Only mode (for workloads < 64GB per socket (128GB per node); no DDR5 memory is needed) - the system boots and operates within the HBM memory only (no code changes necessary). No additional system memory can be installed.
BM2X	Intel SPR HBM CPU SKU- FLAT mode	HBM Flat mode - the HBM and DDR5 memory work together as a single flat memory region (code changes recommended to maximize performance). Supports 2, 4, 8 or 16 DIMMs per compute node
BM2Y	Intel SPR HBM CPU SKU- CACHE mode	HBM Caching mode - the HBM memory is used as a cache, when the memory working set can't completely fit in the 128GB per node HBM memory space (no code changes necessary). Supports 8 or 16 DIMMs per compute node. Requires a DDR5:HBM capacity ratio of between 2:1 and 64:1.

Tip: With Intel Xeon CPU Max processors, if your application has a small enough memory working set to fit entirely in less than 128GB, then it would be possible to not install any DDR5 memory DIMMs in the server.

The following table lists the Intel Xeon CPU Max Series processors supported by the SD650 V3.

Table 15. Intel Xeon CPU Max Series processor support

Part number	Feature code	SKU	Description	Quantity supported
Intel Xeon Max Series processors with integrated 64GB HBM				
CTO only	BTG9	9462	Intel Xeon CPU Max 9462 32C 350W 2.7GHz Processor	2
CTO only	BTG8	9460	Intel Xeon CPU Max 9460 40C 350W 2.2GHz Processor	2
CTO only	BTG7	9468	Intel Xeon CPU Max 9468 48C 350W 2.1GHz Processor	2
CTO only	BTG6	9470	Intel Xeon CPU Max 9470 52C 350W 2.0GHz Processor	2
CTO only	BTG5	9480	Intel Xeon CPU Max 9480 56C 350W 1.9GHz Processor	2

Processor features

Processors supported by the SD650 V3 introduce new embedded accelerators to add even more processing capability:

- QuickAssist Technology (Intel QAT)**

Help reduce system resource consumption by providing accelerated cryptography, key protection, and data compression with Intel QuickAssist Technology (Intel QAT). By offloading encryption and decryption, this built-in accelerator helps free up processor cores and helps systems serve a larger number of clients.
- Intel Dynamic Load Balancer (Intel DLB)**

Improve the system performance related to handling network data on multi-core Intel Xeon Scalable processors. Intel Dynamic Load Balancer (Intel DLB) enables the efficient distribution of network processing across multiple CPU cores/threads and dynamically distributes network data across multiple CPU cores for processing as the system load varies. Intel DLB also restores the order of networking data packets processed simultaneously on CPU cores.
- Intel Data Streaming Accelerator (Intel DSA)**

Drive high performance for storage, networking, and data-intensive workloads by improving streaming data movement and transformation operations. Intel Data Streaming Accelerator (Intel DSA) is designed to offload the most common data movement tasks that cause overhead in data center-scale deployments. Intel DSA helps speed up data movement across the CPU, memory, and caches, as well as all attached memory, storage, and network devices.
- Intel In-Memory Analytics Accelerator (Intel IAA)**

Run database and analytics workloads faster, with potentially greater power efficiency. Intel In-Memory Analytics Accelerator (Intel IAA) increases query throughput and decreases the memory footprint for in-memory database and big data analytics workloads. Intel IAA is ideal for in-memory databases, open source databases and data stores like RocksDB, Redis, Cassandra, and MySQL.
- Intel Advanced Matrix Extensions (Intel AMX)**

Intel Advanced Matrix Extensions (Intel AMX) is a built-in accelerator in all Silver, Gold, and Platinum processors that significantly improves deep learning training and inference. With Intel AMX, you can fine-tune deep learning models or train small to medium models in just minutes. Intel AMX offers discrete accelerator performance without added hardware and complexity.

The processors also support a separate and encrypted memory space, known as the SGX Enclave, for use by Intel Software Guard Extensions (SGX). The size of the SGX Enclave supported varies by processor model. Intel SGX offers hardware-based memory encryption that isolates specific application code and data in memory. It allows user-level code to allocate private regions of memory (enclaves) which are designed to be protected from processes running at higher privilege levels.

The following table summarizes the key features of all supported 5th Gen processors in the SD650 V3.

Table 16. 5th Gen Intel Xeon Processor features

CPU model	Cores/ threads	Core speed (Base / TB max†)	L3 cache*	Max memory speed	UPI 2.0 links & speed	TDP	Accelerators				SGX Enclave Size
							QAT	DLB	DSA	IAA	
5th Gen Intel Xeon Scalable processors											
6526Y	16 / 32	2.8 / 3.9 GHz	37.5 MB*	5200 MHz	3 / 20 GT/s	195W	0	0	1	0	128GB
6534	8 / 16	3.9 / 4.2 GHz	22.5 MB*	4800 MHz	3 / 20 GT/s	195W	0	0	1	0	128GB
6542Y	24 / 48	2.9 / 4.1 GHz	60 MB*	5200 MHz	3 / 20 GT/s	250W	0	0	1	0	128GB
6544Y	16 / 32	3.6 / 4.1 GHz	45 MB*	5200 MHz	3 / 20 GT/s	270W	0	0	1	0	128GB
6548Y+	32 / 64	2.5 / 4.1 GHz	60 MB	5200 MHz	3 / 20 GT/s	250W	1	1	1	1	128GB
6558Q	32 / 64	3.2 / 4.1 GHz	60 MB	5200 MHz	3 / 20 GT/s	350W	0	0	1	0	128GB
8558	48 / 96	2.1 / 4.0 GHz	260 MB*	5200 MHz	4 / 20 GT/s	330W	0	0	1	0	512GB
8562Y+	32 / 64	2.8 / 4.1 GHz	60 MB	5600 MHz	3 / 20 GT/s	300W	1	1	1	1	512GB
8568Y+	48 / 96	2.3 / 4.0 GHz	300 MB*	5600 MHz	4 / 20 GT/s	350W	1	1	1	1	512GB
8570	56 / 112	2.1 / 4.0 GHz	300 MB*	5600 MHz	4 / 20 GT/s	350W	0	0	1	0	512GB
8580	60 / 120	2.0 / 4.0 GHz	300 MB*	5600 MHz	4 / 20 GT/s	350W	0	0	1	0	512GB
8592+	64 / 128	1.9 / 3.9 GHz	320 MB*	5600 MHz	4 / 20 GT/s	350W	1	1	1	1	512GB
8593Q	64 / 128	2.2 / 3.9 GHz	320 MB*	5600 MHz	4 / 20 GT/s	385W	1	1	1	1	512GB

† The maximum single-core frequency at which the processor is capable of operating

* L3 cache is 1.875 MB per core or larger. Processors with a larger L3 cache per core are marked with an *

The following table summarizes the key features of all supported 4th Gen processors in the SD650 V3.

Table 17. 4th Gen Intel Xeon Processor features

CPU model	Cores/ threads	Core speed (Base / TB max†)	L3 cache*	Max memory speed	UPI 2.0 links & speed	TDP	Accelerators				SGX Enclave Size
							QAT	DLB	DSA	IAA	
4th Gen Intel Xeon Scalable processors											
6426Y	16 / 32	2.5 / 4.1 GHz	37.5 MB*	4800 MHz	3 / 16 GT/s	185W	0	0	1	0	128GB
6434	8 / 16	3.7 / 4.1 GHz	22.5 MB*	4800 MHz	3 / 16 GT/s	195W	0	0	1	0	128GB
6442Y	24 / 48	2.6 / 4.0 GHz	60 MB*	4800 MHz	3 / 16 GT/s	225W	0	0	1	0	128GB
6444Y	16 / 32	3.6 / 4.1 GHz	45 MB*	4800 MHz	3 / 16 GT/s	270W	0	0	1	0	128GB
6448Y	32 / 64	2.1 / 4.1 GHz	60 MB	4800 MHz	3 / 16 GT/s	225W	0	0	1	0	128GB
6458Q	32 / 64	3.1 / 4.0 GHz	60 MB	4800 MHz	3 / 16 GT/s	350W	0	0	1	0	128GB
8458P	44 / 88	2.7 / 3.8 GHz	82.5 MB	4800 MHz	3 / 16 GT/s	350W	1	1	1	1	512GB
8460Y+	40 / 80	2.0 / 3.7 GHz	105 MB*	4800 MHz	4 / 16 GT/s	300W	1	1	1	1	128GB
8462Y+	32 / 64	2.8 / 4.1 GHz	60 MB	4800 MHz	3 / 16 GT/s	300W	1	1	1	1	128GB
8468	48 / 96	2.1 / 3.8 GHz	105 MB*	4800 MHz	4 / 16 GT/s	350W	0	0	1	0	512GB
8468V	48 / 96	2.4 / 3.8 GHz	97.5 MB*	4800 MHz	3 / 16 GT/s	330W	1	1	1	1	128GB
8470	52 / 104	2.0 / 3.8 GHz	105 MB*	4800 MHz	4 / 16 GT/s	350W	0	0	1	0	512GB
8470Q	52 / 104	2.1 / 3.8 GHz	105 MB*	4800 MHz	4 / 16 GT/s	350W	0	0	1	0	512GB
8480+	56 / 112	2.0 / 3.8 GHz	105 MB	4800 MHz	4 / 16 GT/s	350W	1	1	1	1	512GB
8490H	60 / 120	1.9 / 3.5 GHz	112.5 MB	4800 MHz	4 / 16 GT/s	350W	4	4	4	4	512GB

† The maximum single-core frequency at with the processor is capable of operating

* L3 cache is 1.875 MB per core or larger. Processors with a larger L3 cache per core are marked with an *

The following table summarizes the key features of all supported Intel Xeon CPU Max Series processors in the SD650 V3.

Table 18. Intel Xeon CPU Max Series features

CPU model	Cores/ threads	Core speed (Base / TB max†)	L3 cache*	Max memory speed	UPI 2.0 links & speed	TDP	Accelerators				SGX Enclave Size
							QAT	DLB	DSA	IAA	
Intel Xeon Max Series processors with integrated 64GB HBM											
9462	32 / 64	2.7 / 3.1 GHz	75 MB*	4800 MHz	3 / 16 GT/s	350W	0	0	4	0	128GB
9460	40 / 80	2.2 / 2.7 GHz	97.5 MB*	4800 MHz	3 / 16 GT/s	350W	0	0	4	0	128GB
9468	48 / 96	2.1 / 2.6 GHz	105 MB*	4800 MHz	4 / 16 GT/s	350W	0	0	4	0	512GB
9470	52 / 104	2.0 / 2.7 GHz	105 MB*	4800 MHz	4 / 16 GT/s	350W	0	0	4	0	512GB
9480	56 / 112	1.9 / 2.6 GHz	112.5 MB*	4800 MHz	4 / 16 GT/s	350W	0	0	4	0	512GB

† The maximum single-core frequency at with the processor is capable of operating

* L3 cache is 1.875 MB per core or larger. Processors with a larger L3 cache per core are marked with an *

Intel On Demand feature licensing

Intel On Demand is a licensing offering from Lenovo for certain 4th Gen and 5th Gen Intel Xeon Scalable processors that implements software-defined silicon (SDSi) features. The licenses allow customers to activate the embedded accelerators and to increase the SGX Enclave size in specific processor models as their workload and business needs change.

The available upgrades are the following:

- Up to 4x QuickAssist Technology (Intel QAT) accelerators
- Up to 4x Intel Dynamic Load Balancer (Intel DLB) accelerators
- Up to 4x Intel Data Streaming Accelerator (Intel DSA) accelerators
- Up to 4x Intel In-Memory Analytics Accelerator (Intel IAA) accelerators
- 512GB SGX Enclave, an encrypted memory space for use by Intel Software Guard Extensions (SGX)

See the [Processor features](#) section for a brief description of each accelerator and the SGX Enclave.

The following table lists the ordering information for the licenses. Accelerator licenses are bundled together based on the suitable workloads each would benefit with the additional accelerators.

Licenses can be activated in the factory (CTO orders) using feature codes, or as field upgrades using the option part numbers. With the field upgrades, they allow customers to only activate the accelerators or to increase the SGX Enclave size when their applications can best take advantage of them.

Intel On Demand is licensed on individual processors. For servers with two processors, customers will need a license for each processor and the licenses of the two processors must match. If customers add a second processor as a field upgrade, then you must ensure that the Intel On Demand licenses match the first processor.

Each license enables a certain quantity of embedded accelerators - the total number of accelerators available after activation is listed in the table. For example, Intel On Demand Communications & Storage Suite 4 (4L47A89451), once applied to the server, will result in a total of 4x QAT, 4x DLB and 4x DSA accelerators to be enabled the processor. The number of IAA accelerators is unchanged in this example.

Table 19. Ordering information for Intel on Demand

Part number	Feature code	License bundle	Accelerators and SGX Enclave enabled after the upgrade is applied (NC = No change)				
			QAT	DLB	DSA	IAA	SGX Enclave
4L47A89451	BX9C	Intel On Demand Communications & Storage Suite 4 (CSS4)	4	4	4	NC	No change
4L47A89452	BX9D	Intel On Demand Analytics Suite 4 (AS4)	NC	NC	4	4	No change
4L47A89453	BX9A	Intel On Demand Communications & Storage Suite 2 (CSS2)	2	2	NC	NC	No change
4L47A89454	BX9B	Intel On Demand Analytics Suite 1 (AS1)	NC	NC	NC	1	No change
4L47A89455	BX9E	Intel On Demand SGX 512GB Enclave	NC	NC	NC	NC	512 GB

The following table lists the 5th Gen processors that support Intel on Demand. The table shows the default accelerators and default SGX Enclave size, and it shows (with green highlight) what the total new accelerators and SGX Enclave would be once the Intel On Demand features have been activated.

Table 20. Intel On Demand support by processor - 5th Gen processors

CPU model	Default accelerators and SGX Enclave					Intel On Demand upgrades					New accelerator quantities and SGX Enclave after applying Intel On Demand				
	QAT	DLB	DSA	IAA	SGX Enclv	BX9C	BX9D	BX9A	BX9B	BX9E	QAT	DLB	DSA	IAA	SGX Enclv
						CSS4 (4xQAT, 4xDLB, 4xDSA)	AS4 (4xDSA, 4xIAA)	CSS2 (2xQAT, 2xDLB)	AS1 (1xIAA)	SGX512					
6526Y	0	0	1	0	128GB	No	No	No	Support	Support	0	0	1	1	512GB
6534	0	0	1	0	128GB	No	No	No	Support	Support	0	0	1	1	512GB
6542Y	0	0	1	0	128GB	No	No	No	Support	Support	0	0	1	1	512GB
6544Y	0	0	1	0	128GB	No	No	No	Support	Support	0	0	1	1	512GB
6548Y+	1	1	1	1	128GB	No	No	Support	No	Support	2	2	1	1	512GB
6558Q	0	0	1	0	128GB	No	No	No	Support	Support	0	0	1	1	512GB
8558	0	0	1	0	512GB	No	Support	No	No	No	0	0	4	4	512GB
8562Y+	1	1	1	1	512GB	No	No	Support	No	No	2	2	1	1	512GB
8568Y+	1	1	1	1	512GB	Support	Support	No	No	No	4	4	4	4	512GB
8570	0	0	1	0	512GB	No	Support	No	No	No	0	0	4	4	512GB
8580	0	0	1	0	512GB	No	Support	No	No	No	0	0	4	4	512GB
8592+	1	1	1	1	512GB	Support	Support	No	No	No	4	4	4	4	512GB
8593Q	1	1	1	1	512GB	No	Support	No	No	No	1	1	4	4	512GB

The following table lists the 4th Gen processors that support Intel on Demand. The table shows the default accelerators and default SGX Enclave size, and it shows (with green highlight) what the total new accelerators and SGX Enclave would be once the Intel On Demand features have been activated.

Table 21. Intel On Demand support by processor - 4th Gen processors

CPU model	Default accelerators and SGX Enclave					Intel On Demand upgrades					New accelerator quantities and SGX Enclave after applying Intel On Demand				
	QAT	DLB	DSA	IAA	SGX Enclv	BX9C	BX9D	BX9A	BX9B	BX9E	Green = additional accelerators/enclave added				
						CSS4 (4xQAT, 4xDLB, 4xDSA)	AS4 (4xDSA, 4xIAA)	CSS2 (2xQAT, 2xDLB)	AS1 (1xIAA)	SGX512	QAT	DLB	DSA	IAA	SGX Enclv
6426Y	0	0	1	0	128GB	No	No	No	Support	Support	0	0	1	1	512GB
6434	0	0	1	0	128GB	No	No	No	Support	Support	0	0	1	1	512GB
6442Y	0	0	1	0	128GB	No	No	No	Support	Support	0	0	1	1	512GB
6444Y	0	0	1	0	128GB	No	No	No	Support	Support	0	0	1	1	512GB
6448Y	0	0	1	0	128GB	No	No	No	Support	Support	0	0	1	1	512GB
6458Q	0	0	1	0	128GB	No	No	No	Support	Support	0	0	1	1	512GB
8458P	1	1	1	1	512GB	No	Support	No	No	No	1	1	4	4	512GB
8460Y+	1	1	1	1	128GB	Support	Support	No	No	Support	4	4	4	4	512GB
8462Y+	1	1	1	1	128GB	No	No	Support	No	Support	2	2	1	1	512GB
8468	0	0	1	0	512GB	No	Support	No	No	No	0	0	4	4	512GB
8468V	1	1	1	1	128GB	No	Support	No	No	Support	1	1	4	4	512GB
8470	0	0	1	0	512GB	No	Support	No	No	No	0	0	4	4	512GB
8470Q	0	0	1	0	512GB	No	Support	No	No	No	0	0	4	4	512GB
8480+	1	1	1	1	512GB	Support	Support	No	No	No	4	4	4	4	512GB
8490H	4	4	4	4	512GB	Processor 8490H does not support Intel on Demand									

Configuration rules:

- Not all processors support Intel On Demand upgrades - see the table for those that do not support Intel On Demand
- Upgrades can be performed in the factory (feature codes) or in the field (part numbers) but not both, and only one time
- Upgrades cannot be removed once activated
- SGX Enclave upgrades are independent of the accelerator upgrades; install either or both as desired
- For processors that support more than one upgrade, all upgrades must be performed at the same time
- Only one of each type of upgrade can be applied to a processor (eg 2x BX9A is not supported; 4x BX9B is not supported)
- The following processors support two accelerator upgrades, Intel On Demand Analytics Suite 4 (4L47A89452) and Intel On Demand Communications & Storage Suite 4 (4L47A89451); the table(s) above shows the accelerators based on both upgrades being applied.
 - Intel Xeon Platinum 8460Y+
 - Intel Xeon Platinum 8480+
 - Intel Xeon Platinum 8568Y+
 - Intel Xeon Platinum 8592+
- The number of accelerators listed for each upgrade is the number of accelerators that will be active one the upgrade is complete (ie the total number, not the number to be added)
- If a server has two processors, then two feature codes must be selected, one for each processor. The upgrades on the two processors must be identical.
- If a one-processor server with Intel On Demand features activated on it has a 2nd processor added as a field upgrade, the 2nd processor must also have the same features activated by purchasing the

appropriate part numbers.

UEFI operating modes

The SD650 V3 offers preset operating modes that affect energy consumption and performance. These modes are a collection of predefined low-level UEFI settings that simplify the task of tuning the server to suit your business and workload requirements.

The following table lists the feature codes that allow you to specify the mode you wish to preset in the factory for CTO orders.

Table 22. UEFI operating mode presets in DCSC

Feature code	Description
BFYB	Operating mode selection for: "Maximum Performance Mode"
BFYC	Operating mode selection for: "Minimal Power Mode"
BFYD	Operating mode selection for: "Efficiency Favoring Power Savings Mode"
BFYE	Operating mode selection for: "Efficiency - Favoring Performance Mode"

The preset modes for the SD650 V3 are as follows:

- **Maximum Performance Mode** (feature BFYB): Achieves maximum performance but with higher power consumption and lower energy efficiency.
- **Minimal Power Mode** (feature BFYC): Minimize the absolute power consumption of the system.
- **Efficiency Favoring Power Savings Mode** (feature BFYD): Maximize the performance/watt efficiency with a bias towards power savings. This is the favored mode for SPECpower benchmark testing, for example.
- **Efficiency Favoring Performance Mode** (feature BFYE): Maximize the performance/watt efficiency with a bias towards performance. This is the favored mode for Energy Star certification, for example.

For details about these preset modes, and all other performance and power efficiency UEFI settings offered in the SD650 V3, see the paper "Tuning UEFI Settings for Performance and Energy Efficiency on Intel Xeon Scalable Processor-Based ThinkSystem Servers", available from <https://lenovopress.lenovo.com/lp1477>.

Memory

The SD650 V3 uses Lenovo TruDDR5 memory operating at up to 5600 MHz with 5th Gen Intel Xeon processors, or up to 4800 MHz with 4th Gen Intel Xeon processors. The server supports 16 DIMMs with 2 processors. The processors have 8 memory channels and support 1 DIMM per channel. The server supports up to 2TB of memory using 16x 128GB 3DS RDIMMs and two processors.

Lenovo TruDDR5 memory uses the highest quality components that are sourced from Tier 1 DRAM suppliers and only memory that meets the strict requirements of Lenovo is selected. It is compatibility tested and tuned to maximize performance and reliability. From a service and support standpoint, Lenovo TruDDR5 memory automatically assumes the system warranty, and Lenovo provides service and support worldwide.

The following table lists the 5600 MHz memory options that are currently supported by the SD650 V3. These DIMMs are only supported with 5th Gen Intel Xeon processors.

Table 23. 5600 MHz memory options

Part number	Feature code	Description	DRAM technology
10x4 RDIMMs - 5600 MHz			
4X77A88052	BWHS	ThinkSystem 64GB TruDDR5 5600MHz (2Rx4) 10x4 RDIMM	16Gb
4X77A88058	BWHV	ThinkSystem 96GB TruDDR5 5600MHz (2Rx4) RDIMM	24Gb
x8 RDIMMs - 5600 MHz			
4X77A88087	BWJE	ThinkSystem 16GB TruDDR5 5600MHz (1Rx8) RDIMM	16Gb
4X77A88051	BWJC	ThinkSystem 32GB TruDDR5 5600MHz (2Rx8) RDIMM	16Gb
4X77A88056	BWSL	ThinkSystem 24GB TruDDR5 5600MHz (1Rx8) RDIMM	24Gb
4X77A88057	BWJD	ThinkSystem 48GB TruDDR5 5600MHz (2Rx8) RDIMM	24Gb
3DS RDIMMs - 5600 MHz			
4X77A88054	BWHU	ThinkSystem 128GB TruDDR5 5600MHz (4Rx4) 3DS RDIMM	16Gb

The following table lists the 4800 MHz memory options that are currently supported by the SD650 V3. These DIMMs are only supported with 4th Gen Intel Xeon processors.

Table 24. 4800 MHz memory options

Part number	Feature code	Description	DRAM technology
9x4 RDIMMs - 4800 MHz			
4X77A77033	BKTN	ThinkSystem 64GB TruDDR5 4800MHz (2Rx4) 9x4 RDIMM	16Gb
x8 RDIMMs - 4800 MHz			
4X77A77029	BKTL	ThinkSystem 16GB TruDDR5 4800MHz (1Rx8) RDIMM	16Gb
4X77A77031	BKTM	ThinkSystem 32GB TruDDR5 4800MHz (2Rx8) RDIMM	16Gb
3DS RDIMMs - 4800 MHz			
4X77A77034	BNFC	ThinkSystem 128GB TruDDR5 4800MHz (4Rx4) 3DS RDIMM v2	16Gb
CTO only	BY8F	ThinkSystem 128GB TruDDR5 4800MHz (4Rx4) 3DS RDIMM v1	16Gb

9x4 RDIMMs (also known as EC4 RDIMMs) are a new lower-cost DDR5 memory option supported in ThinkSystem V3 servers. 9x4 DIMMs offer the same performance as standard RDIMMs (known as 10x4 or EC8 modules), however they support lower fault-tolerance characteristics. Standard RDIMMs and 3DS RDIMMs support two 40-bit subchannels (that is, a total of 80 bits), whereas 9x4 RDIMMs support two 36-bit subchannels (a total of 72 bits). The extra bits in the subchannels allow standard RDIMMs and 3DS RDIMMs to support Single Device Data Correction (SDDC), however 9x4 RDIMMs do not support SDDC. Note, however, that all DDR5 DIMMs, including 9x4 RDIMMs, support Bounded Fault correction, which enables the server to correct most common types of DRAM failures.

For more information on DDR5 memory, see the Lenovo Press paper, *Introduction to DDR5 Memory*, available from <https://lenovopress.com/lp1618>.

Tip: The SD650 V3 server supports two Intel Xeon Max Series processors which each include 64GB of integrated High Bandwidth Memory (HBM2e) for a total of 128GB of memory. With Xeon Max Series processors, if your application has a small enough memory working set to fit entirely in less than 128GB, then it would be possible to not install any DDR5 memory DIMMs in the server.

The following rules apply when selecting the memory configuration:

- 4800 MHz memory is only supported with 4th Gen Intel Xeon Scalable processors and Intel Max Series processors. 5600 MHz memory is only supported with 5th Gen Intel Xeon Scalable processors
- With Intel Xeon Scalable processors, the SD650 V3 only supports quantities of 16 DIMMs with two processors installed; other quantities not supported
- With Intel Max Series processors, the SD650 V3 only supports quantities of 0, 8, or 16 DIMMs with two processors installed; other quantities not supported
- The server supports three types of DIMMs: 9x4 RDIMMs, RDIMMs, and 3DS RDIMMs; UDIMMs and LRDIMMs are not supported
- All memory DIMMs must be identical part numbers
- Memory mirroring is not supported with 9x4 DIMMs

For best performance, consider the following:

- Ensure the memory installed is at least the same speed as the memory bus of the selected processor.
- Populate all 8 memory channels.

The following memory protection technologies are supported:

- ECC detection/correction
- Bounded Fault detection/correction
- SDDC (for x4-based memory DIMMs; look for "x4" in the DIMM description)
- ADDDC (for 10x4-based memory DIMMs, not supported with 9x4 DIMMs)
- Memory mirroring

See the Lenovo Press article "RAS Features of the Lenovo ThinkSystem Intel Servers" for more information about memory RAS features: <https://lenovopress.lenovo.com/lp1711-ras-features-of-the-lenovo-thinksystem-intel-servers>

If memory channel mirroring is used, then DIMMs must be installed in pairs (minimum of one pair per processor), and both DIMMs in the pair must be identical in type and size. 50% of the installed capacity is available to the operating system. Memory rank sparing is not supported.

GPU accelerators

GPUs are not supported in the SD650 V3.

For Intel Xeon Max Series GPU support in a water-cooled solution, the ThinkSystem SD650-I V3 node leverages the identical SD650 V3 node integrating an Intel Xeon Max Series 4-GPU board. For details, see the SD650-I V3 product guide, <https://lenovopress.com/LP1602>.

Internal storage

The SD650 V3 node supports up to four SSDs drives internally in the node, in two bays. These are internal drives that are not front accessible and are not hot-swap.

The SD650 V3 supports either:

- 4x EDSFF E3.S 1T drives in 2 bays
- 4x 7mm 2.5-inch drives in 2 bays
- 2x 15mm 2.5-inch drives in 2 bays

The drive bays may instead be configured as PCIe slots as described in the [I/O expansion options](#) section.

The following figure shows the location and numbering of the drives.

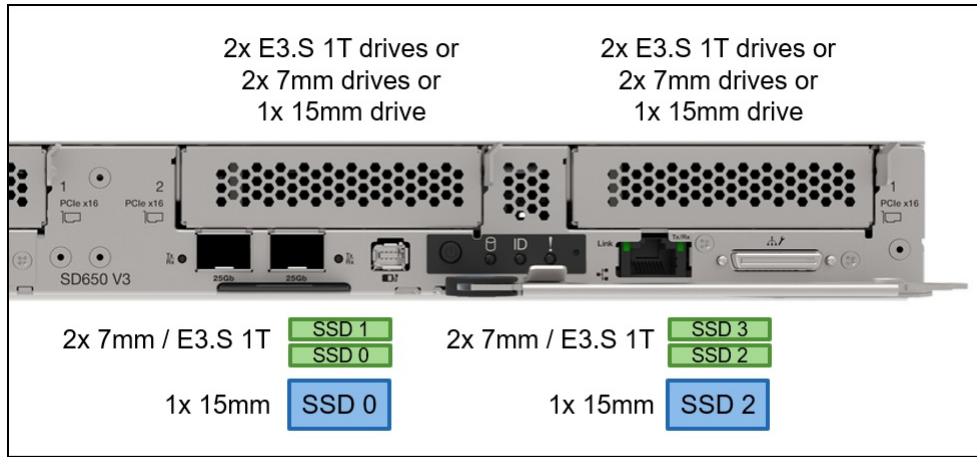

Figure 10. SD650 V3 internal drive bays

Configuration notes:

- The node supports NVMe drives or SATA drives but not both; SAS drives are not supported
- The server may be configured without drives; in such a configuration the OS can be booted from an M.2 drive
- The drives are connected to onboard controllers; RAID functionality is provided using Intel VROC.
- NVMe drives are connected to CPU 1 in all configurations
- Drive numbering is as shown in the above figure.

In addition, the SD650 V3 node a single high-performance M.2 NVMe drive, installed in an adapter mounted on top of the front processor. For details, see the [M.2 drive](#) section.

The feature codes to select the appropriate storage cage are listed in the following table:

Table 25. Drive cage feature codes

Feature code	Description
BKTG	ThinkSystem SD650, SD650-I V3 1x2.5" SATA Storage Cage (1x 15mm drive cage)
BKTH	ThinkSystem SD650, SD650-I V3 2x2.5" SATA Storage Cage (2x 7mm drive cage)
BY1H	ThinkSystem SD650, SD650-I, SD650-N V3 1x2.5" 7mm NVMe Storage Cage
BY1G	ThinkSystem SD650, SD650-I, SD650-N V3 2x2.5" 7mm NVMe Storage Cage
BY1F	ThinkSystem SD650, SD650-I, SD650-N V3 1x2.5" 15mm NVMe Storage Cage
BZ4P	ThinkSystem SD650, SD650-I, SD650-N V3 2x E3.S 1T Storage Cage

The necessary storage cables are auto-derived by the configurator.

To upgrade systems installed in the field with storage options, there are separate kits available that contain both the cage and the necessary cables. The option part numbers of the upgrade kits are listed in the following table.

Table 26. Drive cage field upgrades

Part number	Description	Max per node
4XF7A91150	ThinkSystem SD650, SD650-I, SD650-N V3 15mm Storage Option Upgrade Kit	2
4XF7A80355	ThinkSystem SD650, SD650-I, SD650-N V3 7mm Storage Option Upgrade Kit	2
4XF7A86674	ThinkSystem SD650, SD650-I, SD650-N V3 E3.S 1T Storage Option Upgrade Kit	2

M.2 drive

The SD650 V3 supports one M.2 form-factor NVMe drive for use as an operating system boot solution. The M.2 drive installs into an M.2 adapter which is mounted on top of the front processor in the node. See the internal view of the node in the [Components and connectors](#) section for the location of the M.2 drive.

PCIe x4 interface: In the SD650 V3, the M.2 drive is connected to the processor using a PCIe x4 connection, which enables the M.2 drive to operate at the highest performance.

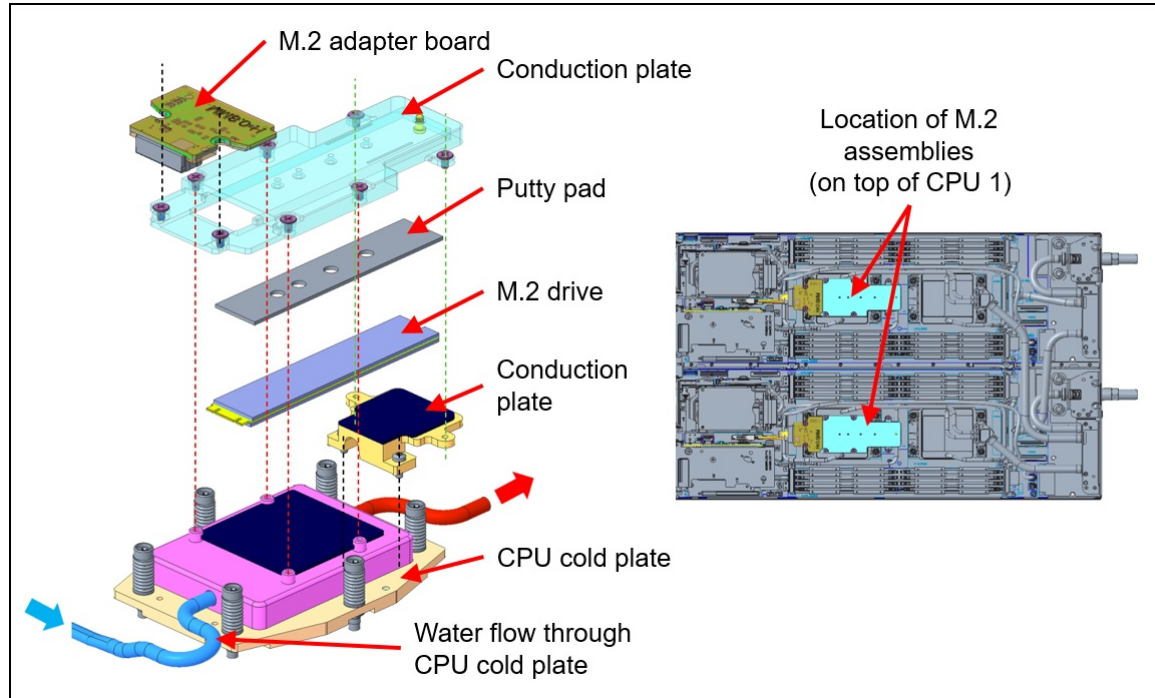

Figure 11. Components and location of the M.2 enablement kit

The ordering information of the M.2 adapter is listed in the following table. Supported drives are listed in the [Internal drive options](#) section.

Table 27. M.2 adapter

Part number	Feature code	Description	Maximum supported
4XF7A86676	BKTF	ThinkSystem SD650, SD650-I, SD650-N V3 DWC M.2 Enablement option upgrade kit	1

Note: In the SD650 V3, the M.2 adapter only supports NVMe drives. SATA M.2 drives are not supported

The M.2 enablement kit has the following features:

- Supports one NVMe M.2 drive
- Supports 80mm and 110mm drive form factors (2280 and 22110)
- PCIe 4.0 x4 NVMe interface to the drive
- Connects to CPU 1 via onboard NVMe connector
- Supports monitoring and reporting of events and temperature through I2C
- Firmware update via Lenovo firmware update tools
- Water-cooled via the attached cold plate

Controllers for internal storage

The drives of the SD650 V3 are connected to integrated SATA and NVMe storage controllers:

- Onboard 6Gb SATA ports
- Onboard PCIe x4 NVMe ports

RAID functionality is provided by Intel VROC, for both SATA drives and NVMe drives.

Internal drive options

The following tables list the drive options for internal storage of the server.

Trayless drives:

- [E3.S EDSFF hot-swap PCIe 5.0 NVMe SSDs](#)
- [7mm 2.5-inch trayless 6 Gb SATA SSDs](#)
- [7mm 2.5-inch trayless PCIe 4.0 NVMe SSDs](#)
- [15mm 2.5-inch trayless PCIe 5.0 NVMe SSDs](#)
- [15mm 2.5-inch trayless PCIe 4.0 NVMe SSDs](#)

M.2 drives:

- [M.2 PCIe 4.0 NVMe drives](#)

M.2 drive support: The use of M.2 drives requires an additional adapter as described in the [M.2 drives](#) subsection.

SED support: The tables include a column to indicate which drives support SED encryption. The encryption functionality can be disabled if needed. Note: Not all SED-enabled drives have "SED" in the description.

Table 28. E3.S EDSFF hot-swap PCIe 5.0 NVMe SSDs

Part number	Feature code	Description	SED support	Max Qty
E3.S trayless SSDs - PCIe 5.0 NVMe - Read Intensive/Entry (<3 DWPD)				
4XB7A88775	BWS1	ThinkSystem E3.S PM1743 1.92TB Read Intensive NVMe PCIe 5.0 x4 Trayless SSD	Support	4
4XB7A88776	BWS2	ThinkSystem E3.S PM1743 3.84TB Read Intensive NVMe PCIe 5.0 x4 Trayless SSD	Support	4
4XB7A88777	BWS3	ThinkSystem E3.S PM1743 7.68TB Read Intensive NVMe PCIe 5.0 x4 Trayless SSD	Support	4
4XB7A88778	BWS4	ThinkSystem E3.S PM1743 15.36TB Read Intensive NVMe PCIe 5.0 x4 Trayless SSD	Support	4

Table 29. 7mm 2.5-inch trayless 6 Gb SATA SSDs

Part number	Feature code	Description	SED support	Max Qty
7mm 2.5-inch trayless SSDs - 6 Gb SATA - Mixed Use/Mainstream (3-5 DWPD)				
4XB7A77060	BKSX	ThinkSystem 2.5" 7mm S4620 480GB Mixed Use SATA 6Gb Trayless SSD	Support	4
4XB7A77061	BKSY	ThinkSystem 2.5" 7mm S4620 960GB Mixed Use SATA 6Gb Trayless SSD	No	4
4XB7A77062	BKSZ	ThinkSystem 2.5" 7mm S4620 1.92TB Mixed Use SATA 6Gb Trayless SSD	No	4
4XB7A78629	BM1F	ThinkSystem 2.5" 7mm S4620 3.84TB Mixed Use SATA 6Gb Trayless SSD	No	4
7mm 2.5-inch trayless SSDs - 6 Gb SATA - Read Intensive/Entry (<3 DWPD)				
4XB7A77056	BKST	ThinkSystem Intel S4520 2.5" 7mm 240GB Entry SATA 6Gb Non-Hot Swap SSD Trayless	No	4
4XB7A77057	BKSU	ThinkSystem Intel S4520 2.5" 7mm 480GB Entry SATA 6Gb Non-Hot Swap SSD Trayless	No	4
4XB7A77058	BKSV	ThinkSystem 2.5" 7mm S4520 960GB Read Intensive SATA 6Gb Trayless SSD	No	4
4XB7A77059	BKSW	ThinkSystem 2.5" 7mm S4520 1.92TB Read Intensive SATA 6Gb Trayless SSD	No	4
4XB7A78627	BM1D	ThinkSystem 2.5" 7mm S4520 3.84TB Read Intensive SATA 6Gb Trayless SSD	No	4
4XB7A78628	BM1E	ThinkSystem 2.5" 7mm S4520 7.68TB Read Intensive SATA 6Gb Trayless SSD	No	4

Table 30. 7mm 2.5-inch trayless PCIe 4.0 NVMe SSDs

Part number	Feature code	Description	SED support	Max Qty
7mm 2.5-inch SSDs - U.3 PCIe 4.0 NVMe - Read Intensive/Entry (<3 DWPD)				
4XB7A90115	BXME	ThinkSystem 2.5" U.2 7mm PM9A3 960GB Read Intensive NVMe PCIe 4.0 x4 Trayless SSD	Support	4
4XB7A90116	BXMD	ThinkSystem 2.5" U.2 7mm PM9A3 1.92TB Read Intensive NVMe PCIe 4.0 x4 Trayless SSD	Support	4
4XB7A90117	BXMC	ThinkSystem 2.5" U.2 7mm PM9A3 3.84TB Read Intensive NVMe PCIe 4.0 x4 Trayless SSD	Support	4
4XB7A13975	BKSQ	ThinkSystem 2.5" 7mm U.3 7450 PRO 960GB Read Intensive NVMe PCIe 4.0 x4 Trayless SSD	Support	4
4XB7A13976	BKWR	ThinkSystem 2.5" 7mm U.3 7450 PRO 1.92TB Read Intensive NVMe PCIe 4.0 x4 Trayless SSD	Support	4
4XB7A13977	BKWS	ThinkSystem 2.5" 7mm U.3 7450 PRO 3.84TB Read Intensive NVMe PCIe 4.0 x4 Trayless SSD	Support	4

Table 31. 15mm 2.5-inch trayless PCIe 5.0 NVMe SSDs

Part number	Feature code	Description	SED support	Max Qty
15mm 2.5-inch SSDs - U.2 PCIe 4.0 NVMe - Read Intensive/Entry (<3 DWPD)				
4XB7A82609	BW8Q	ThinkSystem 2.5" 15mm U.3 PM1743 1.92TB Read Intensive NVMe PCIe 5.0 x4 Trayless SSD	Support	2
4XB7A82411	BW8R	ThinkSystem 2.5" 15mm U.3 PM1743 3.84TB Read Intensive NVMe PCIe 5.0 x4 Trayless SSD	Support	2
4XB7A88392	BW8S	ThinkSystem 2.5" 15mm U.3 PM1743 7.68TB Read Intensive NVMe PCIe 5.0 x4 Trayless SSD	Support	2
4XB7A88393	BW8T	ThinkSystem 2.5" 15mm U.3 PM1743 15.36TB Read Intensive NVMe PCIe 5.0 x4 Trayless SSD	Support	2

Table 32. 15mm 2.5-inch trayless PCIe 4.0 NVMe SSDs

Part number	Feature code	Description	SED support	Max Qty
15mm 2.5-inch SSDs - U.2 PCIe 4.0 NVMe - Write Intensive/Performance (10+ DWPD)				
4XB7A80500	BNUN	ThinkSystem 2.5" 15mm U.2 P5800X 3.2TB Write Intensive NVMe PCIe 4.0 x4 Trayless SSD	No	2
15mm 2.5-inch SSDs - U.2 PCIe 4.0 NVMe - Mixed Use/Mainstream (3-5 DWPD)				
4XB7A76781	BKT5	ThinkSystem 2.5" 15mm U.2 P5620 1.6TB Mixed Use NVMe PCIe 4.0 x4 Trayless SSD	Support	2
4XB7A76782	BKT6	ThinkSystem 2.5" 15mm U.2 P5620 3.2TB Mixed Use NVMe PCIe 4.0 x4 Trayless SSD	Support	2
15mm 2.5-inch SSDs - U.2 PCIe 4.0 NVMe - Read Intensive/Entry (<3 DWPD)				
4XB7A76780	BKT4	ThinkSystem 2.5" 15mm U.2 P5520 1.92TB Read Intensive NVMe PCIe 4.0 x4 Trayless SSD	Support	2
4XB7A17124	BA7P	ThinkSystem 2.5" 15mm U.2 P5520 3.84TB Read Intensive NVMe PCIe 4.0 x4 Trayless SSD	Support	2

Table 33. M.2 PCIe 4.0 NVMe drives

Part number	Feature code	Description	SED support	Max Qty
M.2 SSDs - PCIe 4.0 NVMe - Read Intensive/Entry (<3 DWPD)				
4XB7A90102	BXMH	ThinkSystem M.2 PM9A3 960GB Read Intensive NVMe PCIe 4.0 x4 NHS SSD	Support	1
4XB7A90103	BXMG	ThinkSystem M.2 PM9A3 1.92TB Read Intensive NVMe PCIe 4.0 x4 NHS SSD	Support	1
4XB7A13999	BKSR	ThinkSystem M.2 7450 PRO 960GB Read Intensive NVMe PCIe 4.0 x4 NHS SSD	Support	1
4XB7A14000	BKSS	ThinkSystem M.2 7450 PRO 1.92TB Read Intensive Entry NVMe PCIe 4.0 x4 NHS SSD	Support	1

Optical drives

The server supports the external USB optical drive listed in the following table.

Table 34. External optical drive

Part number	Feature code	Description
7XA7A05926	AVV8	ThinkSystem External USB DVD RW Optical Disk Drive

The drive is based on the Lenovo Slim DVD Burner DB65 drive and supports the following formats: DVD-RAM, DVD-RW, DVD+RW, DVD+R, DVD-R, DVD-ROM, DVD-R DL, CD-RW, CD-R, CD-ROM.

I/O expansion options

The SD650 V3 supports 1x or 2x slots depending on the configuration:

- 1x PCIe 5.0 x16 slot with support for 2x 7mm or 1x 15mm 2.5-inch drive
- 2x PCIe 5.0 x16 slots without 2.5-inch drive support

The location of the slots is shown in the following figure.

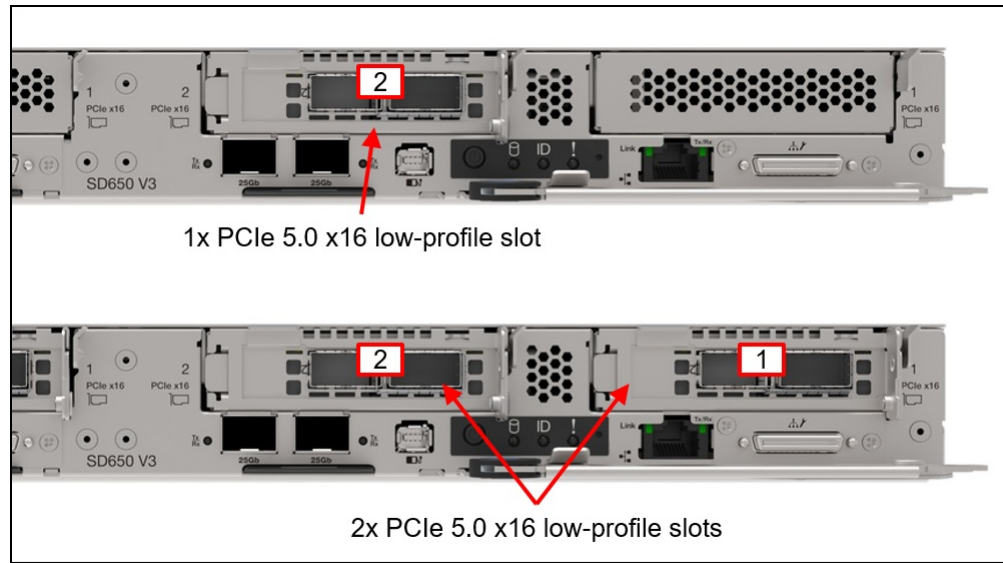

Figure 12. SD650 V3 slot choices

Shared I/O configuration: If the nodes on a tray are configured for Shared I/O networking, then the adapter slots are the "inside" slots (slot 1 on the left node, slot 2 on the right node).

Both slots are implemented using a 1-slot riser. Ordering information is in the following table.

Table 35. Riser ordering information

Part number	Feature code	Description
4TA7A86675	BKTE	ThinkSystem SD650, SD650-I V3 1U PCIe Riser

One or both of these slots can alternatively be configured as internal drive bays, as described in the [Internal storage](#) section.

The SD650 V3 has three onboard network ports:

- 2x 25GbE ports, connected to an onboard Mellanox ConnectX-4 Lx controller, implemented with SFP28 cages for optical or copper connections. Supports 1Gb, 10Gb and 25Gb connections.
- 1x 1GbE port, connected to an onboard Intel I210 controller, implemented with an RJ45 port for copper cabling

Locations of these ports is shown in the [Components and connectors](#) section. The 1GbE port and 25GbE Port 1 both support NC-SI for remote management. For factory orders, to specify which ports should have NC-SI enabled, use the feature codes listed in the [Remote Management](#) section. If neither is chosen, both ports will have NC-SI disabled by default.

For the specifications of the 25GbE ports including the supported transceivers and cables, see the Mellanox ConnectX-4 product guide:

<https://lenovopress.lenovo.com/lp0098-mellanox-connectx-4>

Network adapters

The SD650 V3 supports one or two network adapters installed in the PCIe slots. The following table lists the supported adapters. The node supports the SharedIO or Socket Direct features as indicated in the table.

Table 36. PCIe network adapters and internal cables

Part number	Feature code	Description	Supported connections*		
			Standalone adapter	SharedIO	Socket Direct
Adapters					
4XC7A86671	BKSN	ThinkSystem NVIDIA ConnectX-7 NDR OSFP400 1-port PCIe Gen5 x16 InfiniBand Adapter DWC	Yes (2 max)	No	Yes (1 max)
4XC7A86670	BKSP	ThinkSystem NVIDIA ConnectX-7 NDR OSFP400 1-port PCIe Gen5 x16 InfiniBand Adapter (SharedIO) DWC	No	Yes (1 per tray)	No
4XC7A86669	BKSL	ThinkSystem NVIDIA ConnectX-7 NDR200/HDR QSFP112 2-port PCIe Gen5 x16 InfiniBand Adapter (SharedIO) DWC	Yes (2 max)	Yes (1 per tray)	No
4XC7A86672	BKSK	ThinkSystem Mellanox ConnectX-6 HDR/200GbE QSFP56 1-Port PCIe 4 VPI Adapter (SharedIO) DWC	Yes (2 max)	Yes (1 per tray)†	No
4C57A14179	B4RB	ThinkSystem Mellanox HDR/200GbE 2x PCIe Aux Kit	No	Yes (1 per tray)†	No
Internal cables					
4X97A86673	BRL2	ThinkSystem SD650, SD650-I V3 Auxiliary Cable	No	Yes (1 per tray)	Yes (1)
CTO only	B4RB	ThinkSystem Mellanox HDR/200GbE 2x PCIe Aux Kit	No	Yes (1 per tray)	No

* Numbers in parenthesis are the maximum supported per node for that configuration, except for the SharedIO quantities, which are maximums per tray (2 nodes)

† The ConnectX-6 adapter is not supported in SharedIO mode if water-cooled power supplies are configured

For more information, including the transceivers and cables that each adapter supports, see the list of Lenovo Press Product Guides in the Networking adapters category:

<https://lenovopress.com/servers/options/ethernet>

Shared I/O

The SD650 V3 supports a feature called Shared I/O (SharedIO), also known as NVIDIA Networking Multi-Host technology, where a single network connection is shared between the two nodes in a tray. With Shared I/O, the NVIDIA adapter (feature BKSL, BKSP or BKSK) is installed in one node in a tray, and a cable (feature BRL2 or B4RB) is used to connect the adapter to a PCIe connector on the adjacent node in the same tray. The result is that the two nodes share the network connection of the adapter with significant savings both in the cost of the adapters but also the cost of switch ports.

Configuration rules:

- Shared I/O requires the use of a SharedIO cable, feature BPZG for NDR, or feature B4RB for HDR
- The adapter must be installed in Slot 2 of node 2. The cable connects the adapter to the onboard connector for Slot 1 of node 1
- Slot 1 of each node can be configured for storage, either 2x 7mm drives or 1x 15mm drive per node

Tip: The ConnectX-7 NDR200/HDR adapter (feature BKSL) and the ConnectX-6 HDR/200GbE adapter (feature BKSK) can be used either standalone (maximum 2 per node or 4 per tray) or as part of a Shared I/O configuration (maximum 1 per tray).

Socket Direct

The SD650 V3 also supports a feature called Socket Direct where an adapter installed in a node is connected to both processors in that node at the same time. Socket Direct enables direct PCIe access to both processors, eliminating the need for network traffic having to traverse the inter-process bus. This optimizes overall system performance and maximum throughput for the most demanding applications and markets.

In the SD650 V3, this is achieved by installing the NVIDIA adapter in slot 2 (connects to CPU 2) and a cable (feature BRL2) is used to connect the adapter to the PCIe connector for slot 1 (which connects to CPU 1).

Configuration rules:

- Socket Direct requires the use of cable ThinkSystem SD650 V3 NDR Auxiliary Cable, feature BRL2
- The adapter must be installed in Slot 2 of each node. The cable connects the adapter to the onboard connector for Slot 1
- Slot 1 must remain empty if Socket Direct is configured
- Socket Direct only operates at PCIe Gen 4 speed, however the adapter operates at Gen 4 speed on *each* link, thus matching total Gen 5 speed.

Storage host bus adapters

The SD650 V3 does not support storage host bus adapters.

Flash storage adapters

The SD650 V3 does not support Flash storage adapters.

Cooling

One of the most notable features of the ThinkSystem SD650 V3 offering is direct water cooling. Direct water cooling (DWC) is achieved by circulating the cooling water directly through cold plates that contact the CPU thermal case, DIMMs, and other high-heat-producing components in the node.

One of the main advantages of direct water cooling is the water can be relatively warm and still be effective because water conducts heat much more effectively than air. Depending on the server and power supply configuration as well as environmental factors like water and air temperature, effectively 100% of the heat can be removed by water cooling; in configurations that stay slightly below that, the rest can be easily managed by a standard computer room air conditioner. Measured data at a customer data center shows 98% heat capture at 45°C water inlet temperature and 99% heat capture at 40°C water inlet temperature and 26.6°C ambient temperature with insulated racks using the SD650-N V2.

Allowable inlet temperatures for the water can be as high as 45°C (113°F) with the SD650 V3. In most climates, water-side economizers can supply water at temperatures below 45°C for most of the year. This ability allows the data center chilled water system to be bypassed thus saving energy because the chiller is the most significant energy consumer in the data center. Typical economizer systems, such as dry-coolers, use only a fraction of the energy that is required by chillers, which produce 6-10 °C (43-50 °F) water. The facility energy savings are the largest component of the total energy savings that are realized when the SD650 V3 is deployed.

The advantages of the use of water cooling over air cooling result from water's higher specific heat capacity, density, and thermal conductivity. These features allow water to transmit heat over greater distances with much less volumetric flow and reduced temperature difference as compared to air.

For cooling IT equipment, this heat transfer capability is its primary advantage. Water has a tremendously increased ability to transport heat away from its source to a secondary cooling surface, which allows for large, more optimally designed radiators or heat exchangers rather than small, inefficient fins that are mounted on or near a heat source, such as a CPU.

The ThinkSystem SD650 V3 offering uses the benefits of water by distributing it directly to the highest heat generating node subsystem components. By doing so, the offering realizes 7% - 10% direct energy savings when compared to an air-cooled equivalent. That energy savings results from the removal of the system fans and the lower operating temp of the direct water-cooled system components.

The direct energy savings at the enclosure level, combined with the potential for significant facility energy savings, makes the SD650 V3 an excellent choice for customers that are burdened by high energy costs or with a sustainability mandate.

Water is delivered to each of the nodes from a coolant distribution unit (CDU) via the water manifold. As shown in the following figure, each manifold section attaches to an enclosure and connects directly to the water inlet and outlet connectors for each compute node to deliver water safely and reliably to and from each server tray.

The DWC Manifold is modular and is available in multiple configurations that are based on the number of enclosure drops that are required in a rack. The Manifold scales to support up to six Enclosures in a single rack, as shown in the following figure. Ordering information for the water manifold is in the [Manifold assembly](#) section.

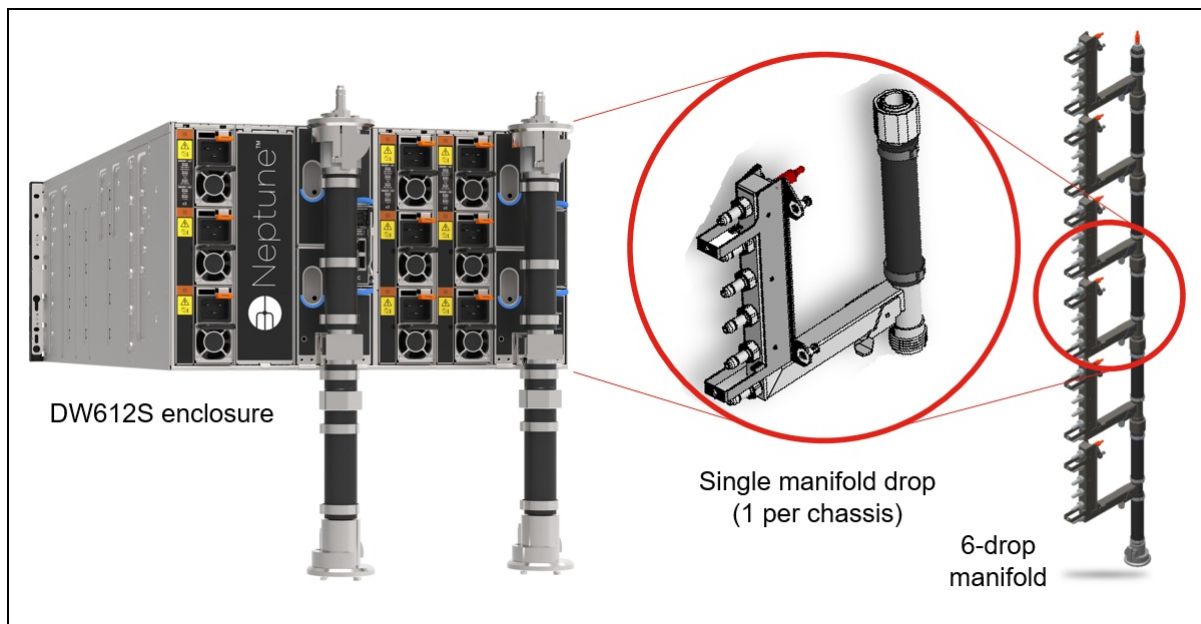

Figure 13. DW612S enclosure and manifold assembly

The water flows through the SD650 V3 tray to cool all major heat-producing components. The inlet water is split into two parallel paths, one for each node in the tray. Each path is then split further to cool the processors, memory, drives (including the M.2 drive) and adapters.

When the DW612S is configured with water-cooled power supplies, an additional water manifold is used to supply water to each of the three power supplies, as shown in the following figure. Ordering information for the manifold is in the [Manifold assembly](#) section.

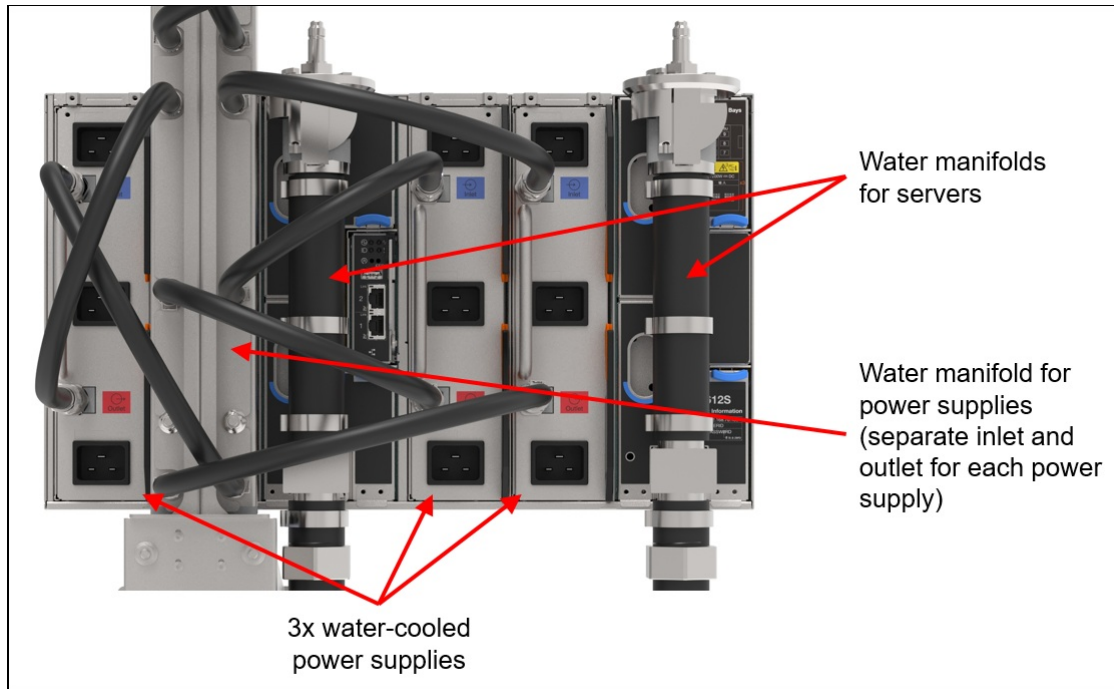

Figure 14. DW612S enclosure with water-cooled power supplies and manifold

During the manufacturing and test cycle, Lenovo's water-cooled nodes are pressure tested with Helium according to ASTM E499 / E499M – 11 (Standard Practice for Leaks Using the Mass Spectrometer Leak Detector in the Detector Probe Mode) and later again with Nitrogen to detect micro-leaks which may be undetectable by pressure testing with water and/or a water/glycol mixture as Helium and Nitrogen have smaller molecule sizes.

This approach also allows Lenovo to ship the systems pressurized without needing to send hazardous antifreeze-components to our customers.

Onsite the materials used within the water loop from the CDU to the nodes should be limited to copper alloys with brazed joints, Stainless steels with TIG and MIG welded joints and EPDM rubber. In some instances, PVC might be an acceptable choice within the facility.

The water the system is filled with must be reasonably clean, bacteria-free water (< 100 CFU/ml) such as de-mineralized water, reverse osmosis water, de-ionized water, or distilled water. It must be filtered with in-line 50 micron filter. Biocide and Corrosion inhibitors ensure a clean operation without microbiological growth or corrosion.

Lenovo Data Center Power and Cooling Services can support you in the design, implementation and maintenance of the facility water-cooling infrastructure.

Power supplies

The DW612S enclosure supports air-cooled or water-cooled power supplies. The use of water-cooled power supplies enables an even greater amount of heat can be removed from the data center using water instead of air-conditioning.

The DW612S supports the following power supply quantities, however the power needs depend on the power requirements of the installed server node trays:

- 6x or 9x air-cooled power supplies, each with 1x C19 power connector
- 2x or 3x water-cooled power supplies, each with 3x C19 power connectors

Tip: Use Lenovo Capacity Planner to determine the power needs for your rack installation. See the [Lenovo Capacity Planner](#) section for details.

The power supplies provide N+1 redundancy (water-cooled power supplies each count as 3), depending on population and configuration of the node trays. Power policies with no redundancy also are supported. Water-cooled power supply units contain 3 discreet power supplies, which means that with 3 water-cooled power supply units, 8+1 redundancy is supported.

Topics in this section:

- [Power supply layout](#)
- [Power supply ordering information](#)
- [Power output](#)
- [Power cables](#)

Power supply layout

Power supplies are implemented in the DW612S enclosure in vertical cages, with three air-cooled power supplies or one water-cooled power supply in each cage. The following figure shows nine air-cooled power supplies installed in three cages.

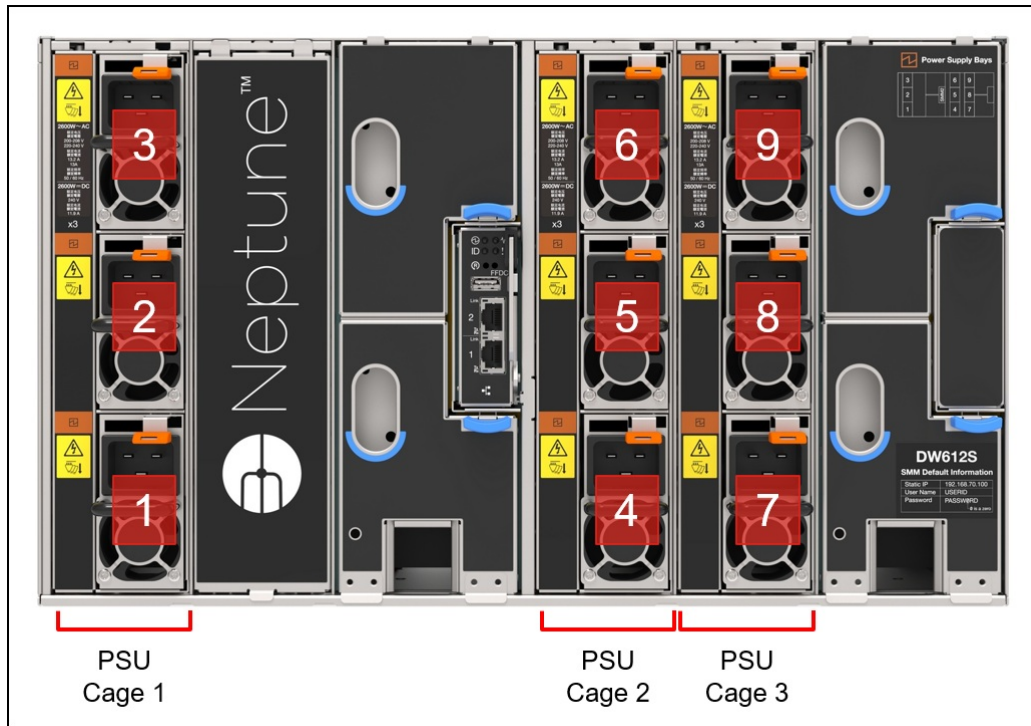

Figure 15. Power supplies and cages in the DW612S enclosure (shown with 9 air-cooled power supplies)

The following figure shows the DW612S with three water-cooled power supplies installed.

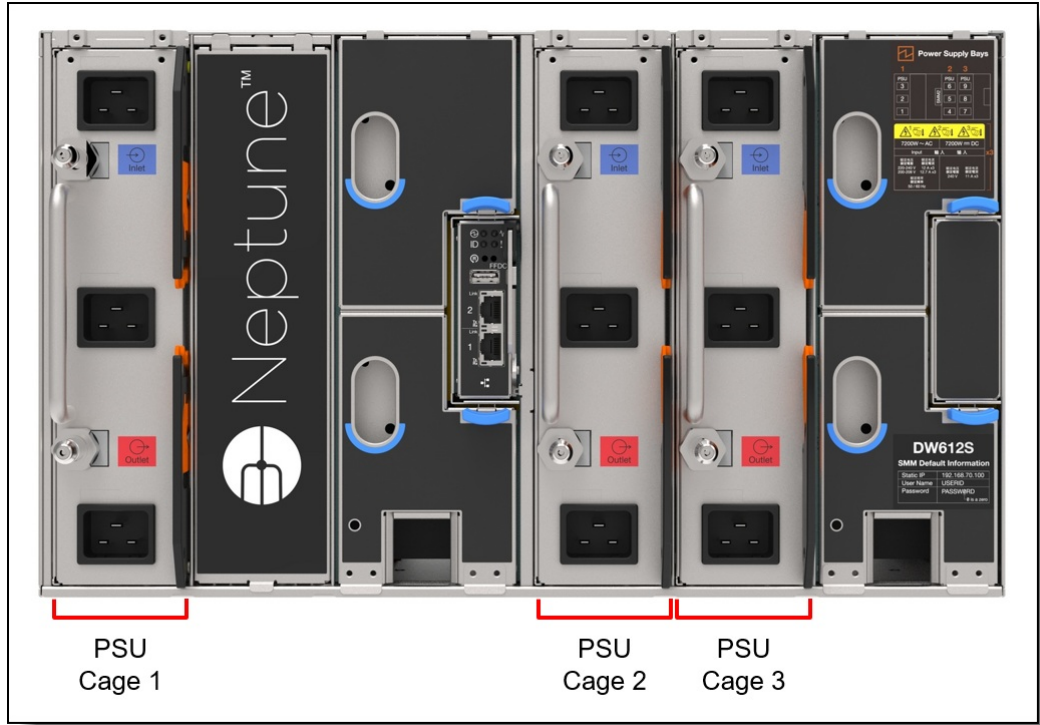

Figure 16. Power supplies and cages in the DW612S enclosure (shown with 3 water-cooled power supplies)

For configurations with six air-cooled power supplies, you can specify whether you want 3 power supplies in each of 2 cages, or you can specify if you want 2 power supplies installed in each of 3 cages. The latter means that you can later upgrade the enclosure to a total of 9 power supplies by adding one more power supply to each cage.

The following table lists the supported power supply configurations.

Table 37. Power supply cage configuration choices

Feature code	Description
BF7J	ThinkSystem DW612S 2 PSU Cage with 6 PSU Configuration
BF7K	ThinkSystem DW612S 3 PSU Cage with 6 PSU Configuration
BF7L	ThinkSystem DW612S 3 PSU Cage with 9 PSU Configuration

Power supply ordering information

The following table lists the supported power supplies for use in the DW612S enclosure with SD650 V3 nodes installed. Mixing of power supply capacities (different part number) is not supported.

Table 38. Power supply options

Part number	Feature	Description	Connector	Quantity support	80 PLUS	110V AC	220V AC	240V DC China only
Air cooled power supplies								
4P57A69999	BF7M	ThinkSystem DW612 2400W 230V Platinum Hot-Swap Gen2 Power Supply	1x C19	6, 9	Platinum	No	Yes	Yes
4P57A72667	BKTJ	ThinkSystem 2600W 230V Titanium Hot-Swap Gen2 Power Supply	1x C19	6, 9	Titanium	No	Yes	Yes
Water cooled power supplies								
4P57A72669	BKTK	ThinkSystem DW612S 7200W (230V/115V) Hot-Swap Power Supply	3x C19	2, 3	Titanium	No	Yes	Yes

The power supply units have the following features:

- 80 PLUS Platinum or Titanium certified as listed in the table above
- Supports N+1 power redundancy or non-redundant power configurations:
 - For air-cooled power supplies: 5+1 (for 6 PSUs) or 8+1 (for 9 PSUs)
 - For water-cooled power supplies: 5+1 (for 2 PSUs) or 8+1 (for 3 PSUs)
- Power management configured through the SMM
- Integrated 2500 RPM fan
- Built-in overload and surge protection
- Supports high-range voltage only: 200 - 240 V

Power output

The power rating of each power supply (2400W or 2600W) is dependent on the voltage of the input supply. A 208V supply will be able to generate less power than a 240V supply for example. You will need to take this into consideration when determining your power needs. The following table provides the details for each supported power supply unit. A yellow cell indicates lower power availability than the rated power.

Table 39. Power availability based on the voltage of the supply

Description	2400W 230V Platinum Power Supply	2600W 230V Titanium Power Supply	7200W 230V Titanium Power Supply
Power Rating	2400W	2600W	7200W
Output with 200-208Vac supply	2400W	2400W	6900W
Output with 220-240Vac supply	2400W	2600W	7200W

Power cables

The power supplies in the DW612S enclosure have C19 connectors and support the following rack power cables.

Table 40. C19 rack power cables

Part number	Feature code	Description
4L67A86677	BPJ0	0.5m, 16A/100-250V, C19 to IEC 320-C20 Rack Power Cable
4L67A86678	B4L0	1.0m, 16A/100-250V, C19 to IEC 320-C20 Rack Power Cable
4L67A86679	B4L1	1.5m, 16A/100-250V, C19 to IEC 320-C20 Rack Power Cable
4L67A86680	B4L2	2.0m, 16A/100-250V, C19 to IEC 320-C20 Rack Power Cable
39Y7916	6252	2.5m, 16A/100-250V, C19 to IEC 320-C20 Rack Power Cable
4L67A86681	B4L3	4.3m, 16A/100-250V, C19 to IEC 320-C20 Rack Power Cable

System Management

The SD650 V3 contains an integrated service processor, XClarity Controller 2 (XCC), which provides advanced control, monitoring, and alerting functions. The XCC2 is based on the AST2600 baseboard management controller (BMC) using a dual-core ARM Cortex A7 32-bit RISC service processor running at 1.2 GHz.

Topics in this section:

- [Local console](#)
- [External Diagnostics Handset](#)
- [System status with XClarity Mobile](#)
- [Remote management](#)
- [XCC2 Platinum](#)
- [Remote management using the SMM](#)
- [Lenovo HPC & AI Software Stack](#)
- [Lenovo XClarity Provisioning Manager](#)
- [Lenovo XClarity Essentials](#)
- [Lenovo XClarity Administrator](#)
- [Lenovo XClarity Integrators](#)
- [Lenovo XClarity Energy Manager](#)
- [Lenovo Capacity Planner](#)

Local console

The SD650 V3 node supports a local console with the use of a console breakout cable. The cable connects to the port on the front of the node as shown in the following figure.

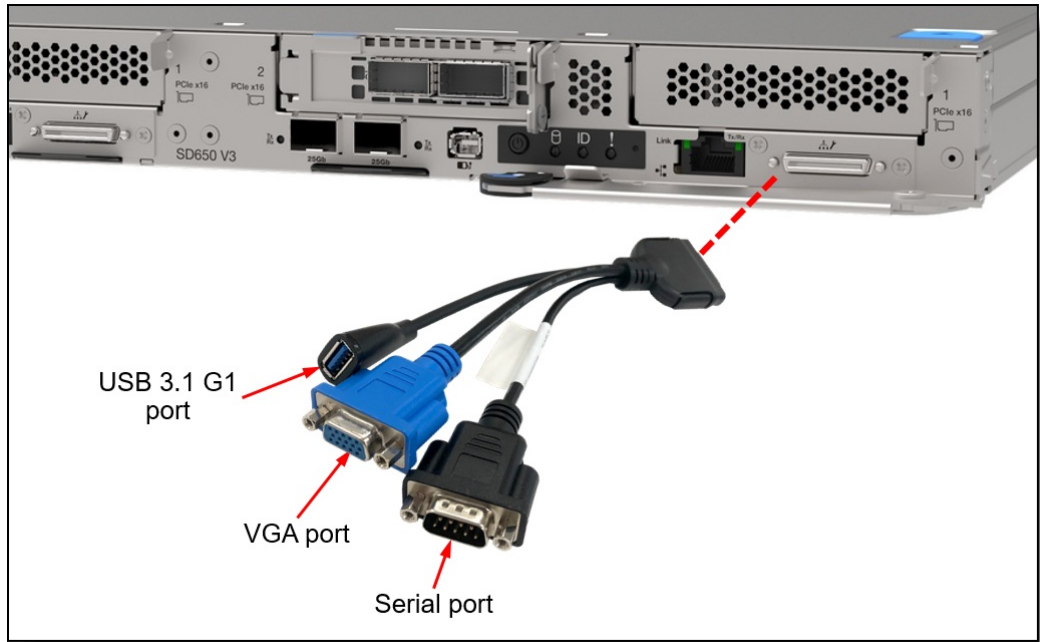

Figure 17. Console breakout cable

The cable has the following connectors:

- VGA port
- Serial port
- USB 3.1 Gen 1 (5 Gb/s) port

Tip: USB 3.0 was renamed to USB 3.1 Gen 1 by the USB Implementers Forum. The terms "USB 3.0" and "USB 3.1 Gen 1" are used interchangeably - both offer a 5 Gb/s USB connection.

As well as local console functions, the USB port on the breakout cable also supports the use of the XClarity Mobile app as described in the next section.

Ordering information for the cable is listed in the following table.

Table 41. Console breakout cable ordering information

Part number	Feature code	Description
4X97A83213	1410 BMJB	ThinkSystem USB 3.0 Console Breakout Cable for Dense Systems v2

External Diagnostics Handset

The SD650 V3 has a port to connect an External Diagnostics Handset as shown in the following figure.

The External Diagnostics Handset allows quick access to system status, firmware, network, and health information. The LCD display on the panel and the function buttons give you access to the following information:

- Active alerts
- Status Dashboard
- System VPD: machine type & mode, serial number, UUID string
- System firmware levels: UEFI and XCC firmware
- XCC network information: hostname, MAC address, IP address, DNS addresses
- Environmental data: Ambient temperature, CPU temperature, AC input voltage, estimated power consumption
- Active XCC sessions
- System reset action

The handset has a magnet on the back of it to allow you to easily mount it on a convenient place on any rack cabinet.

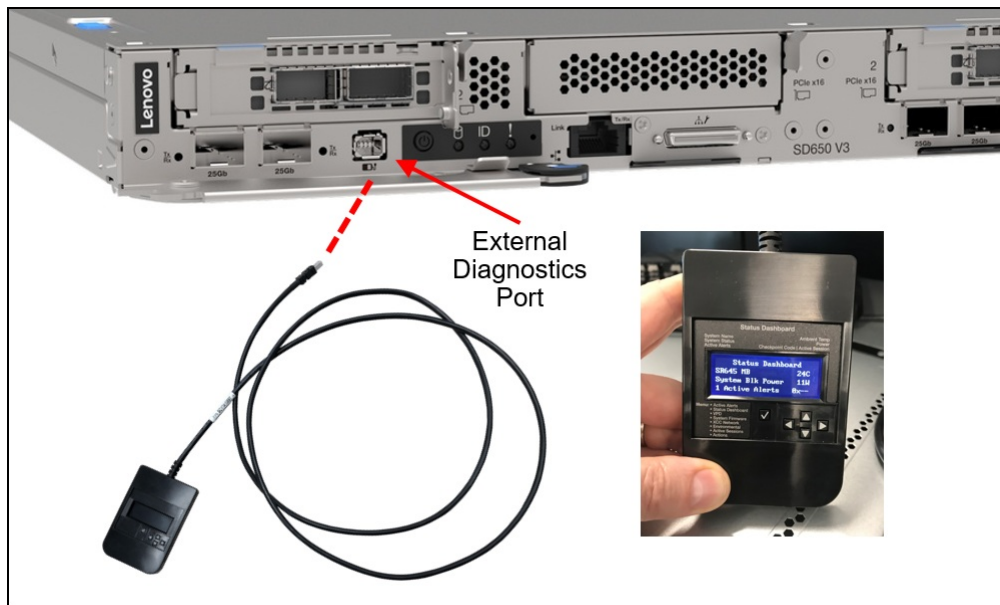

Figure 18. SD650 V3 External Diagnostics Handset

Ordering information for the External Diagnostics Handset with is listed in the following table.

Table 42. External Diagnostics Handset ordering information

Part number	Feature code	Description
4TA7A64874	1410 BEUX	ThinkSystem External Diagnostics Handset

System status with XClarity Mobile

The XClarity Mobile app includes a tethering function where you can connect your Android or iOS device to the server via USB to see the status of the server.

The steps to connect the mobile device are as follows:

1. Enable USB Management on the server, by holding down the ID button for 3 seconds (or pressing the dedicated USB management button if one is present)

2. Connect the mobile device via a USB cable to the server's USB port with the management symbol



3. In iOS or Android settings, enable Personal Hotspot or USB Tethering
4. Launch the Lenovo XClarity Mobile app

Once connected you can see the following information:

- Server status including error logs (read only, no login required)
- Server management functions (XClarity login credentials required)

Remote management

The 1Gb onboard port and one of the 25Gb onboard ports (port 1) on the front of the SD650 V3 offer a connection to the XCC for remote management. This shared-NIC functionality allows the ports to be used both for operating system networking and for remote management.

Remote server management is provided through industry-standard interfaces:

- Intelligent Platform Management Interface (IPMI) Version 2.0
- Simple Network Management Protocol (SNMP) Version 3 (no SET commands; no SNMP v1)
- Common Information Model (CIM-XML)
- Representational State Transfer (REST) support
- Redfish support (DMTF compliant)
- Web browser - HTML 5-based browser interface (Java and ActiveX not required) using a responsive design (content optimized for device being used - laptop, tablet, phone) with NLS support

The 1Gb port and 25Gb Port 1 support NC-SI. You can enable NC-SI in the factory using the feature codes listed in the following table. If neither feature code is selected, both ports will have NC-SI disabled.

Table 43. Enabling NC-SI on the embedded network ports

Feature code	Description
BEXY	ThinkSystem NC-SI enabled on SFP28 Port (Port 1)
BEXZ	ThinkSystem NC-SI enabled on RJ45 Port

IPMI via the Ethernet port (IPMI over LAN) is supported, however it is disabled by default. For CTO orders you can specify whether you want the feature enabled or disabled in the factory, using the feature codes listed in the following table.

Table 44. IPMI-over-LAN settings

Feature code	Description
B7XZ	Disable IPMI-over-LAN (default)
B7Y0	Enable IPMI-over-LAN

XCC2 Platinum

The XCC2 service processor in the SD650 V3 supports an upgrade to the Platinum level of features. Compared to the XCC functions of ThinkSystem V2 and earlier systems, Platinum adds the same features as Enterprise and Advanced levels in ThinkSystem V2, plus additional features.

XCC2 Platinum adds the following Enterprise and Advanced functions:

- Remotely viewing video with graphics resolutions up to 1600x1200 at 75 Hz with up to 23 bits per pixel, regardless of the system state

- Remotely accessing the server using the keyboard and mouse from a remote client
- International keyboard mapping support
- Syslog alerting
- Redirecting serial console via SSH
- Component replacement log (Maintenance History log)
- Access restriction (IP address blocking)
- Lenovo SED security key management
- Displaying graphics for real-time and historical power usage data and temperature
- Boot video capture and crash video capture
- Virtual console collaboration - Ability for up to 6 remote users to be log into the remote session simultaneously
- Remote console Java client
- Mapping the ISO and image files located on the local client as virtual drives for use by the server
- Mounting the remote ISO and image files via HTTPS, SFTP, CIFS, and NFS
- Power capping
- System utilization data and graphic view
- Single sign on with Lenovo XClarity Administrator
- Update firmware from a repository
- License for XClarity Energy Manager

XCC2 Platinum also adds the following features that are new to XCC2:

- System Guard - Monitor hardware inventory for unexpected component changes, and simply log the event or prevent booting
- Enterprise Strict Security mode - Enforces CNSA 1.0 level security
- Neighbor Group - Enables administrators to manage and synchronize configurations and firmware level across multiple servers

Ordering information is listed in the following table. XCC2 Platinum is a software license upgrade - no additional hardware is required.

Table 45. XCC2 Platinum license upgrade

Part number	Feature code	Description
7S0X000KWW	SBCV	Lenovo XClarity Controller 2 (XCC2) Platinum Upgrade

With XCC2 Platinum, for CTO orders, you can request that System Guard be enabled in the factory and the first configuration snapshot be recorded. To add this to an order, select feature code listed in the following table. The selection is made in the Security tab of the DCSC configurator.

Table 46. Enable System Guard in the factory (CTO orders)

Feature code	Description
BUT2	Install System Guard

For more information about System Guard, see https://pubs.lenovo.com/xcc2/NN1ia_c_systemguard

Remote management using the SMM

The DW612S enclosure includes a System Management Module 2 (SMM), installed in the rear of the enclosure. See [Enclosure rear view](#) for the location of the SMM. The SMM provides remote management of both the enclosure and the individual servers installed in the enclosure. The SMM can be accessed through a web browser interface and via Intelligent Platform Management Interface (IPMI) 2.0 commands.

The SMM provides the following functions:

- Remote connectivity to XCC controllers in each node in the enclosure
- Node-level reporting and control (for example, node virtual reseal/reset)
- Enclosure power management
- Enclosure thermal management
- Enclosure inventory

The following figure shows the LEDs and connectors of the SMM.

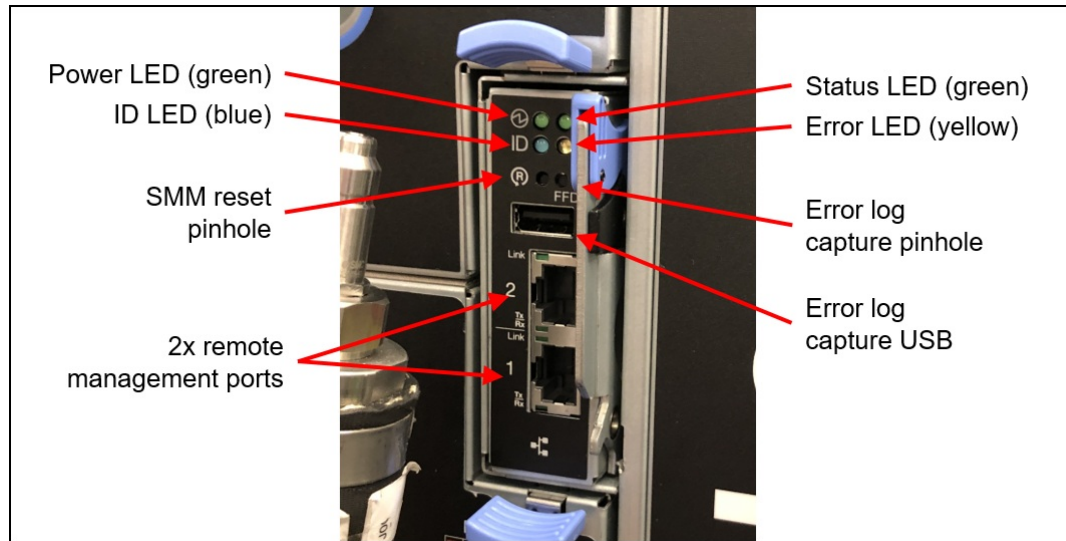

Figure 19. System management module in the DW612S enclosure

The SMM has the following ports and LEDs:

- 2x Gigabit Ethernet RJ45 ports for remote management access
- USB port and activation button for service
- SMM reset button
- System error LED (yellow)
- Identification (ID) LED (blue)
- Status LED (green)
- System power LED (green)

The USB service button and USB service port are used to gather service data in the event of an error. Pressing the service button copies First Failure Data Collection (FFDC) data to a USB key installed in the USB service port. The reset button is used to perform an SMM reset (short press) or to restore the SMM back to factory defaults (press for 4+ seconds).

The use of two RJ45 Ethernet ports enables the ability to daisy-chain the Ethernet management connections thereby reducing the number of ports you need in your management switches and reducing the overall cable density needed for systems management. With this feature you can connect the first SMM to your management network and the SMM in a second enclosure connects to the first SMM. The SMM in the third enclosure can then connect to the SMM in the second enclosure.

Up to 7 enclosures can be connected in a daisy-chain configuration and all servers in those enclosures can be managed remotely via one single Ethernet connection.

Notes:

- If you are using IEEE 802.1D spanning tree protocol (STP) then at most 6 enclosures can be connected together
- Do not form a loop with the network cabling. The dual-port SMM at the end of the chain should not be connected back to the switch that is connected to the top of the SMM chain.

Lenovo HPC & AI Software Stack

The Lenovo HPC & AI Software Stack combines open-source with proprietary best-of-breed Supercomputing software to provide the most consumable open-source HPC software stack embraced by all Lenovo HPC customers.

It provides a fully tested and supported, complete but customizable HPC software stack to enable the administrators and users in optimally and environmentally sustainable utilizing their Lenovo Supercomputers.

The Lenovo HPC & AI Software Stack is built on the most widely adopted and maintained HPC community software for orchestration and management. It integrates third party components especially around programming environments and performance optimization to complement and enhance the capabilities, creating the organic umbrella in software and service to add value for our customers.

The key open-source components of the software stack are as follows:

- **Confluent Management**
Confluent is Lenovo-developed open-source software designed to discover, provision, and manage HPC clusters and the nodes that comprise them. Confluent provides powerful tooling to deploy and update software and firmware to multiple nodes simultaneously, with simple and readable modern software syntax.
- **SLURM Orchestration**
Slurm is integrated as an open source, flexible, and modern choice to manage complex workloads for faster processing and optimal utilization of the large-scale and specialized high-performance and AI resource capabilities needed per workload provided by Lenovo systems. Lenovo provides support in partnership with SchedMD.
- **LiCO Webportal**
Lenovo Intelligent Computing Orchestration (LiCO) is a Lenovo-developed consolidated Graphical User Interface (GUI) for monitoring, managing and using cluster resources. The webportal provides workflows for both AI and HPC, and supports multiple AI frameworks, including TensorFlow, Caffe, Neon, and MXNet, allowing you to leverage a single cluster for diverse workload requirements.
- **Energy Aware Runtime**
EAR is a powerful European open-source energy management suite supporting anything from monitoring over power capping to live-optimization during the application runtime. Lenovo is collaborating with Barcelona Supercomputing Centre (BSC) and EAS4DC on the continuous development and support and offers three versions with differentiating capabilities.

For more information and ordering information, see the Lenovo HPC & AI Software Stack product guide: <https://lenovopress.com/lp1651>

Lenovo XClarity Provisioning Manager

Lenovo XClarity Provisioning Manager (LXPM) is a UEFI-based application embedded in ThinkSystem servers and accessible via the F1 key during system boot.

LXPM provides the following functions:

- Graphical UEFI Setup
- System inventory information and VPD update
- System firmware updates (UEFI and XCC)
- RAID setup wizard
- OS installation wizard (including unattended OS installation)
- Diagnostics functions

Lenovo XClarity Essentials

Lenovo offers the following XClarity Essentials software tools that can help you set up, use, and maintain the server at no additional cost:

- **Lenovo Essentials OneCLI**

OneCLI is a collection of server management tools that uses a command line interface program to manage firmware, hardware, and operating systems. It provides functions to collect full system health information (including health status), configure system settings, and update system firmware and drivers.

- **Lenovo Essentials UpdateXpress**

The UpdateXpress tool is a standalone GUI application for firmware and device driver updates that enables you to maintain your server firmware and device drivers up-to-date and help you avoid unnecessary server outages. The tool acquires and deploys individual updates and UpdateXpress System Packs (UXSPs) which are integration-tested bundles.

- **Lenovo Essentials Bootable Media Creator**

The Bootable Media Creator (BOMC) tool is used to create bootable media for offline firmware update.

For more information and downloads, visit the Lenovo XClarity Essentials web page:

<http://support.lenovo.com/us/en/documents/LNVO-center>

Lenovo XClarity Administrator

Lenovo XClarity Administrator is a centralized resource management solution designed to reduce complexity, speed response, and enhance the availability of Lenovo systems and solutions. It provides agent-free hardware management for ThinkSystem servers, in addition to ThinkServer, System x, and Flex System servers. The administration dashboard is based on HTML 5 and allows fast location of resources so tasks can be run quickly.

Because Lenovo XClarity Administrator does not require any agent software to be installed on the managed endpoints, there are no CPU cycles spent on agent execution, and no memory is used, which means that up to 1GB of RAM and 1 - 2% CPU usage is saved, compared to a typical managed system where an agent is required.

Lenovo XClarity Administrator is an optional software component for the SD650 V3. The software can be downloaded and used at no charge to discover and monitor the SD650 V3 and to manage firmware upgrades.

If software support is required for Lenovo XClarity Administrator, or premium features such as configuration management and operating system deployment are required, Lenovo XClarity Pro software subscription should be ordered. Lenovo XClarity Pro is licensed on a per managed system basis, that is, each managed Lenovo system requires a license.

The following table lists the Lenovo XClarity software license options.

Table 47. Lenovo XClarity Pro ordering information

Part number	Feature code	Description
00MT201	1339	Lenovo XClarity Pro, per Managed Endpoint w/1 Yr SW S&S
00MT202	1340	Lenovo XClarity Pro, per Managed Endpoint w/3 Yr SW S&S
00MT203	1341	Lenovo XClarity Pro, per Managed Endpoint w/5 Yr SW S&S
7S0X000HWW	SAYV	Lenovo XClarity Pro, per Managed Endpoint w/6 Yr SW S&S
7S0X000JWW	SAYW	Lenovo XClarity Pro, per Managed Endpoint w/7 Yr SW S&S

Lenovo XClarity Administrator offers the following standard features that are available at no charge:

- Auto-discovery and monitoring of Lenovo systems
- Firmware updates and compliance enforcement
- External alerts and notifications via SNMP traps, syslog remote logging, and e-mail
- Secure connections to managed endpoints
- NIST 800-131A or FIPS 140-2 compliant cryptographic standards between the management solution and managed endpoints
- Integration into existing higher-level management systems such as cloud automation and orchestration tools through REST APIs, providing extensive external visibility and control over hardware resources
- An intuitive, easy-to-use GUI
- Scripting with Windows PowerShell, providing command-line visibility and control over hardware resources

Lenovo XClarity Administrator offers the following premium features that require an optional Pro license:

- Pattern-based configuration management that allows to define configurations once and apply repeatedly without errors when deploying new servers or redeploying existing servers without disrupting the fabric
- Bare-metal deployment of operating systems and hypervisors to streamline infrastructure provisioning

For more information, refer to the Lenovo XClarity Administrator Product Guide:

<http://lenovopress.com/tips1200>

Lenovo XClarity Integrators

Lenovo also offers software plug-in modules, Lenovo XClarity Integrators, to manage physical infrastructure from leading external virtualization management software tools including those from Microsoft and VMware.

These integrators are offered at no charge, however if software support is required, a Lenovo XClarity Pro software subscription license should be ordered.

Lenovo XClarity Integrators offer the following additional features:

- Ability to discover, manage, and monitor Lenovo server hardware from VMware vCenter or Microsoft System Center
- Deployment of firmware updates and configuration patterns to Lenovo x86 rack servers and Flex System from the virtualization management tool
- Non-disruptive server maintenance in clustered environments that reduces workload downtime by dynamically migrating workloads from affected hosts during rolling server updates or reboots
- Greater service level uptime and assurance in clustered environments during unplanned hardware events by dynamically triggering workload migration from impacted hosts when impending hardware failures are predicted

For more information about all the available Lenovo XClarity Integrators, see the Lenovo XClarity Administrator Product Guide: <https://lenovopress.com/tips1200-lenovo-xclarity-administrator>

Lenovo XClarity Energy Manager

Lenovo XClarity Energy Manager (LXEM) is a power and temperature management solution for data centers. It is an agent-free, web-based console that enables you to monitor and manage power consumption and temperature in your data center through the management console. It enables server density and data center capacity to be increased through the use of power capping.

LXEM is a licensed product. A single-node LXEM license is included with the XClarity Controller Platinum upgrade as described in the [Remote Management](#) section. If your server does not have the XCC Platinum upgrade, Energy Manager licenses can be ordered as shown in the following table.

Table 48. Lenovo XClarity Energy Manager

Part number	Description
4L40E51621	Lenovo XClarity Energy Manager Node License (1 license needed per server)

For more information about XClarity Energy Manager, see the following resources:

- Lenovo Support page:
<https://datacentersupport.lenovo.com/us/en/solutions/Invo-lxem>
- Lenovo Information Center:
https://sysmgt.lenovofiles.com/help/topic/LXEM/lxem_overview.html?cp=4

Lenovo Capacity Planner

Lenovo Capacity Planner is a power consumption evaluation tool that enhances data center planning by enabling IT administrators and pre-sales professionals to understand various power characteristics of racks, servers, and other devices. Capacity Planner can dynamically calculate the power consumption, current, British Thermal Unit (BTU), and volt-ampere (VA) rating at the rack level, improving the planning efficiency for large scale deployments.

For more information, refer to the Capacity Planner web page:
<http://datacentersupport.lenovo.com/us/en/solutions/Invo-lcp>

Security

Topics in this section:

- [Security features](#)
- [Platform Firmware Resiliency - Lenovo ThinkShield](#)
- [Intel Transparent Supply Chain](#)
- [Security standards](#)

Security features

The server offers the following electronic security features:

- System Guard (part of [XCC Platinum](#)) - Proactive monitoring of hardware inventory for unexpected component changes
- Administrator and power-on password
- Trusted Platform Module (TPM) supporting TPM 2.0 (no support for TPM 1.2)
- Support for an optional Nationz TPM 2.0, available only in China (CTO only)

The server is NIST SP 800-147B compliant.

The following table lists the security options for the SD650 V3.

Table 49. Security features

Part number	Feature code	Description
CTO only	B8LE	ThinkSystem NationZ TPM 2.0 for PRC (China customers only)

Platform Firmware Resiliency - Lenovo ThinkShield

Lenovo's ThinkShield Security is a transparent and comprehensive approach to security that extends to all dimensions of our data center products: from development, to supply chain, and through the entire product lifecycle.

The ThinkSystem SD650 V3 includes Platform Firmware Resiliency (PFR) hardware Root of Trust (RoT) which enables the system to be NIST SP800-193 compliant. This offering further enhances key platform subsystem protections against unauthorized firmware updates and corruption, to restore firmware to an integral state, and to closely monitor firmware for possible compromise from cyber attacks.

PFR operates upon the following server components:

- UEFI image – the low-level server firmware that connects the operating system to the server hardware
- XCC image – the management “engine” software that controls and reports on the server status separate from the server operating system
- FPGA image – the code that runs the server’s lowest level hardware controller on the motherboard

The Lenovo Platform Root of Trust Hardware performs the following three main functions:

- Detection – Measures the firmware and updates for authenticity
- Recovery – Recovers a corrupted image to a known-safe image
- Protection – Monitors the system to ensure the known-good firmware is not maliciously written

These enhanced protection capabilities are implemented using a dedicated, discrete security processor whose implementation has been rigorously validated by leading third-party security firms. Security evaluation results and design details are available for customer review – providing unprecedented transparency and assurance.

The SD650 V3 includes support for Secure Boot, a UEFI firmware security feature developed by the UEFI Consortium that ensures only immutable and signed software are loaded during the boot time. The use of Secure Boot helps prevent malicious code from being loaded and helps prevent attacks, such as the installation of rootkits. Lenovo offers the capability to enable secure boot in the factory, to ensure end-to-end protection. Alternatively, Secure Boot can be left disabled in the factory, allowing the customer to enable it themselves at a later point, if desired.

The following table lists the relevant feature code(s).

Table 50. Secure Boot options

Part number	Feature code	Description	Purpose
CTO only	B0MK	Enable TPM 2.0	Configure the system without Secure Boot enabled. Customers can enable Secure Boot later if desired.

Tip: If Secure Boot is not enabled in the factory, it can be enabled later by the customer. However once Secure Boot is enabled, it cannot be disabled.

Intel Transparent Supply Chain

Add a layer of protection in your data center and have peace of mind that the server hardware you bring into it is safe authentic and with documented, testable, and provable origin.

Lenovo has one of the world’s best supply chains, as ranked by Gartner Group, backed by extensive and mature supply chain security programs that exceed industry norms and US Government standards. Now we are the first Tier 1 manufacturer to offer Intel® Transparent Supply Chain in partnership with Intel, offering you an unprecedented degree of supply chain transparency and assurance.

To enable Intel Transparent Supply Chain for the Intel-based servers in your order, add the following feature code in the [DCSC configurator](#), under the Security tab.

Table 51. Intel Transparent Supply Chain ordering information

Feature code	Description
BB0P	Intel Transparent Supply Chain

For more information on this offering, see the paper *Introduction to Intel Transparent Supply Chain on Lenovo ThinkSystem Servers*, available from <https://lenovopress.com/lp1434-introduction-to-intel-transparent-supply-chain-on-thinksystem-servers>.

Security standards

The SD650 V3 supports the following security standards and capabilities:

- **Industry Standard Security Capabilities**

- Intel CPU Enablement
 - AES-NI (Advanced Encryption Standard New Instructions)
 - CbNt (Converged Boot Guard and Trusted Execution Technology)
 - CET (Control flow Enforcement Technology)
 - Hardware-based side channel attack resilience enhancements
 - MKTME/TME (Multi-Key Total Memory Encryption)
 - SGX (Software Guard eXtensions)
 - SGX-TEM (Trusted Environment Mode)
 - TDX (Trust Domain Extensions)
 - TXT (Trusted eXecution Technology)
 - VT (Virtualization Technology)
 - XD (eXecute Disable)
- Microsoft Windows Security Enablement
 - Credential Guard
 - Device Guard
 - Host Guardian Service
- TCG (Trusted Computing Group) TPM (Trusted Platform Module) 2.0
- UEFI (Unified Extensible Firmware Interface) Forum Secure Boot

- **Hardware Root of Trust and Security**

- Independent security subsystem providing platform-wide NIST SP800-193 compliant Platform Firmware Resilience (PFR)
- Management domain RoT supplemented by the Secure Boot features of XCC

- **Platform Security**

For more information on platform security, see the paper “How to Harden the Security of your ThinkSystem Server and Management Applications” available from <https://lenovopress.com/lp1260-how-to-harden-the-security-of-your-thinksystem-server>.

- Boot and run-time firmware integrity monitoring with rollback to known-good firmware (e.g., “self-healing”)
- Non-volatile storage bus security monitoring and filtering
- Resilient firmware implementation, such as to detect and defeat unauthorized flash writes or SMM (System Management Mode) memory incursions
- Patented IPMI KCS channel privileged access authorization (USPTO Patent# 11,256,810)
- Host and management domain authorization, including integration with CyberArk for enterprise password management
- KMIP (Key Management Interoperability Protocol) compliant, including support for IBM SKLM

- and Thales KeySecure
- Reduced “out of box” attack surface
- Configurable network services
- FIPS 140-3 (in progress) validated cryptography for XCC
- CNSA Suite 1.0 Quantum-resistant cryptography for XCC
- Lenovo System Guard
- **Standards Compliance and/or Support**
 - NIST SP800-131A rev 2 “Transitioning the Use of Cryptographic Algorithms and Key Lengths”
 - NIST SP800-147B “BIOS Protection Guidelines for Servers”
 - NIST SP800-193 “Platform Firmware Resiliency Guidelines”
 - ISO/IEC 11889 “Trusted Platform Module Library”
 - Common Criteria TCG Protection Profile for “PC Client Specific TPM 2.0”
 - European Union Commission Regulation 2019/424 (“ErP Lot 9”) “Ecodesign Requirements for Servers and Data Storage Products” Secure Data Deletion
 - Optional FIPS 140-2 validated Self-Encrypting Disks (SEDs) with external KMIP-based key management
- **Product and Supply Chain Security**
 - Suppliers validated through Lenovo’s Trusted Supplier Program
 - Developed in accordance with Lenovo’s Secure Development Lifecycle (LSDL)
 - Continuous firmware security validation through automated testing, including static code analysis, dynamic network and web vulnerability testing, software composition analysis, and subsystem-specific testing, such as UEFI security configuration validation
 - Ongoing security reviews by US-based security experts, with attestation letters available from our third-party security partners
 - Digitally signed firmware, stored and built on US-based infrastructure and signed on US-based Hardware Security Modules (HSMs)
 - Manufacturing transparency via Intel Transparent Supply Chain (for details, see <https://lenovopress.com/lp1434-introduction-to-intel-transparent-supply-chain-on-lenovo-thinksystem-servers>)
 - TAA (Trade Agreements Act) compliant manufacturing, by default in Mexico for North American markets with additional US and EU manufacturing options
 - US 2019 NDAA (National Defense Authorization Act) Section 889 compliant

Operating system support

The server supports the following operating systems:

- Red Hat Enterprise Linux 8.6
- Red Hat Enterprise Linux 8.8
- Red Hat Enterprise Linux 9.0
- Red Hat Enterprise Linux 9.2
- SUSE Linux Enterprise Server 15 SP4
- SUSE Linux Enterprise Server 15 SP5
- SUSE Linux Enterprise Server 15 Xen SP4
- SUSE Linux Enterprise Server 15 Xen SP5
- Ubuntu 22.04 LTS 64-bit

The server is also certified or tested with the following operating systems:

- Ubuntu
- Rocky Linux
- AlmaLinux

See Operating System Interoperability Guide (OSIG) for the complete list of supported, certified, and tested operating systems, including version and point releases: <https://lenovopress.lenovo.com/osig#servers=sd650-v3-7d7m>

Also review the latest LeSI Best Recipe to see the operating systems that are supported via Lenovo Scalable Infrastructure (LeSI): <https://support.lenovo.com/us/en/solutions/HT505184#5>

Physical and electrical specifications

Six SD650 V3 server trays are installed in the DW612S enclosure. Each SD650 V3 tray has the following dimensions:

- Width: 438 mm (17.2 inches)
- Height: 41 mm (1.6 inches)
- Depth: 693 mm (27.3 inches) (747 mm, including the water connections at the rear of the server)

The DW612S enclosure has the following overall physical dimensions, excluding components that extend outside the standard chassis, such as EIA flanges and power supply handles:

- Width: 447 mm (17.6 inches)
- Height: 264 mm (10.4 inches)
- Depth: 933 mm (36.7 inches)

The following table lists the detailed dimensions. See the figure below for the definition of each dimension.

Table 52. Detailed dimensions

Dimension	Description
483 mm	X_a = Width, to the outsides of the front EIA flanges
447 mm	X_b = Width, to the rack rail mating surfaces
447 mm	X_c = Width, to the outer most chassis body feature
264 mm	Y_a = Height, from the bottom of chassis to the top of the chassis
916 mm	Z_a = Depth, from the rack flange mating surface to the rearmost I/O port surface
916 mm	Z_b = Depth, from the rack flange mating surface to the rearmost feature of the chassis body
972 mm	Z_c = Depth, from the rack flange mating surface to the rearmost feature such as power supply handle
17 mm	Z_d = Depth, from the forwardmost feature on front of EIA flange to the rack flange mating surface
17 mm	Z_e = Depth, from the front of security bezel (if applicable) or forwardmost feature to the rack flange mating surface

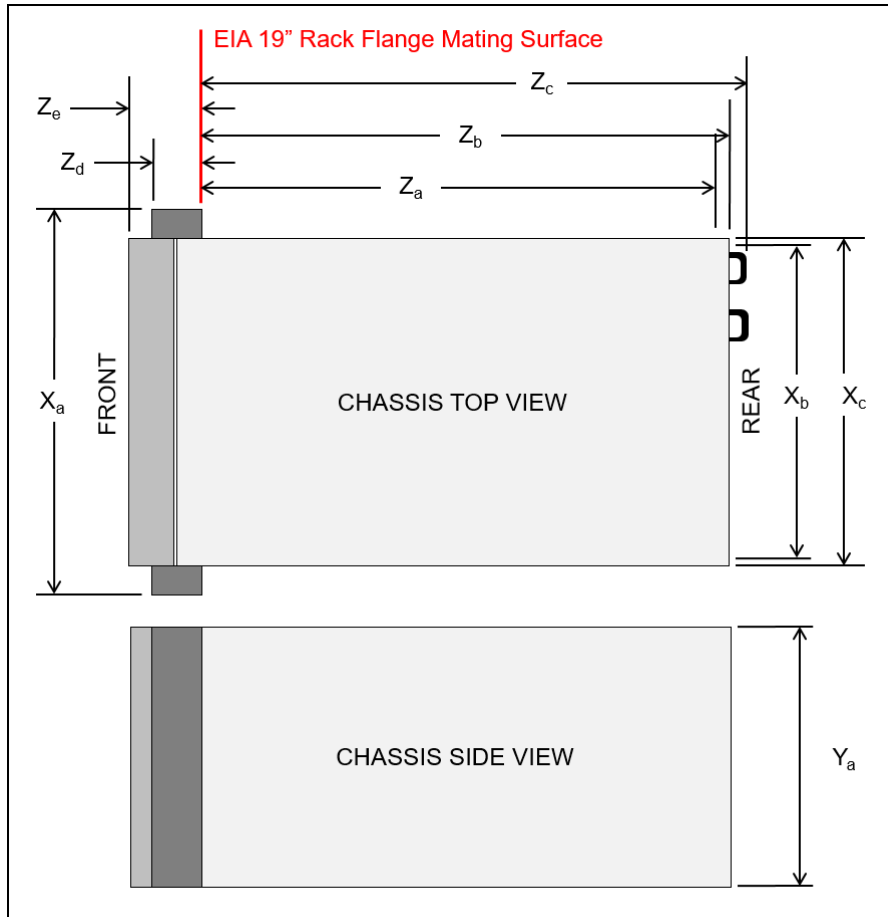

Figure 20. Enclosure dimensions

The SD650 V3 tray has the following maximum weight:

- 20.7 kg (45.6 lb)

The DW612S enclosure has the following weight:

- Empty enclosure (with midplane and cables): 24.3 kg (53.5 lb)
- Fully configured enclosure:
 - With 9x air-cooled power supplies and 6x SD650 V3 server trays (12 nodes): 182.9 kg (403 lb) (without water manifold)
 - with 3x water-cooled power supplies and 6x SD650 V3 server trays (12 nodes): 188.7 kg (416 lb) (without water manifold)

The enclosure has the following electrical specifications for AC input power supplies:

- Input voltage:
 - 200 to 240 (nominal) Vac, 50 Hz or 60 Hz
 - 180 to 300 Vdc (China only)
- Max current for 2600W power supplies:
 - 200-208V AC: 13.2A
 - 220-240V AC: 13A
 - 240V DC: 11.9A (China only)
- Max current for 7200W power supplies (each of 3 inputs):
 - 200-208V AC: 12.7A
 - 220-240V AC: 12A

- 240V DC: 11A (China only)

Operating environment

The SD650 V3 server trays and DW612S enclosure are supported in the following environment:

Water requirements

- Water Temperature: ASHRAE W45: up to 45°C (113°F) at the manifold
 - CPUs up to 350W TDP
 - DIMMs up to 64GB capacity
 - NVIDIA HDR/NDR cards up to 200Gb/sec
- Maximum pressure: 4.4 bar per rack

Water flow rate:

- Minimum water flow rate: 6.0 liters per minute per enclosure, assuming 1.0 liters per minute per compute tray with 6 trays per enclosure (1 tray consists of 2 compute nodes)
- For processors below 300W: 7.5 liters per minute per enclosure, assuming 1.25 liters per minute per compute tray with 6 trays per enclosure
- For processors 300W and above: 9.0 liters per minute per enclosure, assuming 1.5 liters per minute per compute tray with 6 trays per enclosure
- For Intel Xeon Platinum 6458Q and 8470Q processors: 18 liters per minute per enclosure, assuming 3.0 liters per minute per compute tray with 6 trays per enclosure
- For Intel Xeon CPU Max 9480/9470 processors: 18 liters per minute per enclosure, assuming 3.0 liters per minute per compute tray with 6 trays per enclosure
- For Intel Xeon CPU Max 9468/9460/9462 processors: 12 liters per minute per enclosure, assuming 2.0 liters per minute per compute tray with 6 trays per enclosure

Note: The water required to initially fill the system side cooling loop must be reasonably clean, bacteria-free water (<100 CFU/ml) such as de-mineralized water, reverse osmosis water, de-ionized water, or distilled water. The water must be filtered with an in-line 50 micron filter (approximately 288 mesh). The water must be treated with anti-biological and anti-corrosion measures.

Air temperature requirements

- Operating: ASHRAE A2: 10°C to 35°C (50°F to 95°F); when the altitude exceeds 900 m (2953 ft), the maximum ambient temperature value decreases by 1°C (1.8°F) with every 300 m (984 ft) of altitude increase.
- Powered off: 5°C to 45°C (41°F to 113°F)
- Shipping/storage: -40°C to 60°C (-40°F to 140°F)

Relative humidity (non-condensing)

- Operating: ASHRAE Class A2: 8% - 80%, maximum dew point : 21°C (70°F)
- Shipment/storage: 8% - 90%

Particulate contamination

Airborne particulates (including metal flakes or particles) and reactive gases acting alone or in combination with other environmental factors such as humidity or temperature might damage the system that might cause the system to malfunction or stop working altogether.

The following specifications indicate the limits of particulates that the system can tolerate:

- Reactive gases:
 - The copper reactivity level shall be less than 200 Angstroms per month (Å/month)
 - The silver reactivity level shall be less than 200 Å/month

- Airborne particulates:
 - The room air should be continuously filtered with MERV 8 filters.
 - Air entering a data center should be filtered with MERV 11 or preferably MERV 13 filters.
 - The deliquescent relative humidity of the particulate contamination should be more than 60% RH
 - Environment must be free of zinc whiskers

For additional information, see the Specifications section of the documentation for the server, available from the Lenovo Documents site, <https://pubs.lenovo.com/>

Regulatory compliance

The SD650 V3 conforms to the following standards:

- ANSI/UL 62368-1
- IEC 62368-1 (CB Certificate and CB Test Report)
- CSA C22.2 No. 62368-1
- Brazil INMETRO
- South Africa NRCS LOA
- Ukraine UkrCEPRO
- Morocco CMIM Certification (CM)
- Russia, Belorussia and Kazakhstan, TP EAC 037/2016 (for RoHS)
- CE, UKCA Mark (EN55032 Class A, EN62368-1, EN55035, EN61000-3-11, EN61000-3-12, (EU) 2019/424, and EN IEC 63000 (RoHS))
- FCC - Verified to comply with Part 15 of the FCC Rules, Class A
- Canada ICES-003, issue 7, Class A
- CISPR 32, Class A, CISPR 35
- Korea KN32, Class A, KN35
- Japan VCCI, Class A
- Taiwan BSMI CNS15936, Class A; Section 5 of CNS15663
- Australia/New Zealand AS/NZS CISPR 32, Class A; AS/NZS 62368.1
- SGS, VOC Emission
- Energy Star 4.0
- EPEAT (NSF/ ANSI 426) Bronze
- Japanese Energy-Saving Act
- EU2019/424 Energy Related Product (ErP Lot9)
- China CELP certificate, HJ 2507-2011

The DW612S conforms to the following standards:

- ANSI/UL 62368-1
- IEC 62368-1 (CB Certificate and CB Test Report)
- CSA C22.2 No. 62368-1
- Mexico NOM-019
- Brazil INMETRO
- South Africa NRCS LOA
- Ukraine UkrCEPRO
- Morocco CMIM Certification (CM)
- Russia, Belorussia and Kazakhstan, TP EAC 037/2016 (for RoHS)
- CE, UKCA Mark (EN55032 Class A, EN62368-1, EN55035, EN61000-3-11, EN61000-3-12, (EU) 2019/424, and EN IEC 63000 (RoHS))
- FCC - Verified to comply with Part 15 of the FCC Rules, Class A
- Canada ICES-003, issue 7, Class A
- CISPR 32, Class A, CISPR 35
- Korea KN32, Class A, KN35
- Japan VCCI, Class A
- Taiwan BSMI CNS15936, Class A; Section 5 of CNS15663
- Australia/New Zealand AS/NZS CISPR 32, Class A; AS/NZS 62368.1
- SGS, VOC Emission
- Energy Star 3.0
- Energy Star 4.0
- EPEAT (NSF/ ANSI 426) Bronze
- Japanese Energy-Saving Act
- EU2019/424 Energy Related Product (ErP Lot9)
- China CELP certificate, HJ 2507-2011

Warranty and Support

The server and enclosure have the following warranty:

- Lenovo ThinkSystem SD650 V3 (7D7M) - 3-year warranty
- Lenovo ThinkSystem DW612S Enclosure (7D1L) - 3-year warranty
- Lenovo Neptune DWC Node Manifold (5469) - 3-year warranty
- Lenovo Neptune DWC RM100 In-Rack CDU (7DBL) - 1-year warranty through the vendor (Cooltera)
- Genie Lift GL-8 Material Lift (7D5Y) - 3-year warranty through the vendor (Genie)

The standard warranty terms are customer-replaceable unit (CRU) and onsite (for field-replaceable units FRUs only) with standard call center support during normal business hours and 9x5 Next Business Day Parts Delivered.

Lenovo's additional support services provide a sophisticated, unified support structure for your data center, with an experience consistently ranked number one in customer satisfaction worldwide. Available offerings include:

- **Premier Support**

Premier Support provides a Lenovo-owned customer experience and delivers direct access to technicians skilled in hardware, software, and advanced troubleshooting, in addition to the following:

- Direct technician-to-technician access through a dedicated phone line
- 24x7x365 remote support
- Single point of contact service
- End to end case management
- Third-party collaborative software support
- Online case tools and live chat support
- On-demand remote system analysis

- **Warranty Upgrade (Preconfigured Support)**

Services are available to meet the on-site response time targets that match the criticality of your systems.

- 3, 4, or 5 years of service coverage
- 1-year or 2-year post-warranty extensions
- **Foundation Service:** 9x5 service coverage with next business day onsite response. YourDrive YourData is an optional extra (see below).
- **Essential Service:** 24x7 service coverage with 4-hour onsite response or 24-hour committed repair (available only in select markets). Bundled with YourDrive YourData.
- **Advanced Service:** 24x7 service coverage with 2-hour onsite response or 6-hour committed repair (available only in select markets). Bundled with YourDrive YourData.

- **Managed Services**

Lenovo Managed Services provides continuous 24x7 remote monitoring (plus 24x7 call center availability) and proactive management of your data center using state-of-the-art tools, systems, and practices by a team of highly skilled and experienced Lenovo services professionals.

Quarterly reviews check error logs, verify firmware & OS device driver levels, and software as needed. We'll also maintain records of latest patches, critical updates, and firmware levels, to ensure your systems are providing business value through optimized performance.

- **Technical Account Management (TAM)**

A Lenovo Technical Account Manager helps you optimize the operation of your data center based on a deep understanding of your business. You gain direct access to your Lenovo TAM, who serves as your single point of contact to expedite service requests, provide status updates, and furnish reports to track incidents over time. In addition, your TAM will help proactively make service recommendations and manage your service relationship with Lenovo to make certain your needs are met.

- **Enterprise Server Software Support**

Enterprise Software Support is an additional support service providing customers with software support on Microsoft, Red Hat, SUSE, and VMware applications and systems. Around the clock availability for critical problems plus unlimited calls and incidents helps customers address challenges fast, without incremental costs. Support staff can answer troubleshooting and diagnostic questions, address product comparability and interoperability issues, isolate causes of problems, report defects to software vendors, and more.

- **YourDrive YourData**

Lenovo's YourDrive YourData is a multi-drive retention offering that ensures your data is always under your control, regardless of the number of drives that are installed in your Lenovo server. In the unlikely event of a drive failure, you retain possession of your drive while Lenovo replaces the failed drive part. Your data stays safely on your premises, in your hands. The YourDrive YourData service can be purchased in convenient bundles and is optional with Foundation Service. It is bundled with Essential Service and Advanced Service.

- **Health Check**

Having a trusted partner who can perform regular and detailed health checks is central to maintaining efficiency and ensuring that your systems and business are always running at their best. Health Check supports Lenovo-branded server, storage, and networking devices, as well as select Lenovo-supported products from other vendors that are sold by Lenovo or a Lenovo-Authorized Reseller.

Examples of region-specific warranty terms are second or longer business day parts delivery or parts-only base warranty.

If warranty terms and conditions include onsite labor for repair or replacement of parts, Lenovo will dispatch a service technician to the customer site to perform the replacement. Onsite labor under base warranty is limited to labor for replacement of parts that have been determined to be field-replaceable units (FRUs). Parts that are determined to be customer-replaceable units (CRUs) do not include onsite labor under base warranty.

If warranty terms include parts-only base warranty, Lenovo is responsible for delivering only replacement parts that are under base warranty (including FRUs) that will be sent to a requested location for self-service. Parts-only service does not include a service technician being dispatched onsite. Parts must be changed at customer's own cost and labor and defective parts must be returned following the instructions supplied with the spare parts.

Lenovo Service offerings are region-specific. Not all preconfigured support and upgrade options are available in every region. For information about Lenovo service upgrade offerings that are available in your region, refer to the following resources:

- Service part numbers in Lenovo Data Center Solution Configurator (DCSC):
<http://dcsc.lenovo.com/#!/services>
- Lenovo Services Availability Locator
<http://lenovocator.com/>

For service definitions, region-specific details, and service limitations, please refer to the following documents:

- Lenovo Statement of Limited Warranty for Infrastructure Solutions Group (ISG) Servers and System Storage
<http://pcsupport.lenovo.com/us/en/solutions/ht503310>
- Lenovo Data Center Services Agreement
<http://support.lenovo.com/us/en/solutions/ht116628>

Services

Lenovo Services is a dedicated partner to your success. Our goal is to reduce your capital outlays, mitigate your IT risks, and accelerate your time to productivity.

Note: Some service options may not be available in all markets or regions. For more information, go to <https://www.lenovo.com/services>. For information about Lenovo service upgrade offerings that are available in your region, contact your local Lenovo sales representative or business partner.

Here's a more in-depth look at what we can do for you:

- **Asset Recovery Services**

Asset Recovery Services (ARS) helps customers recover the maximum value from their end-of-life equipment in a cost-effective and secure way. On top of simplifying the transition from old to new equipment, ARS mitigates environmental and data security risks associated with data center equipment disposal. Lenovo ARS is a cash-back solution for equipment based on its remaining market value, yielding maximum value from aging assets and lowering total cost of ownership for your customers. For more information, see the ARS page, <https://lenovopress.com/lp1266-reduce-e-waste-and-grow-your-bottom-line-with-lenovo-ars>.

- **Assessment Services**

An Assessment helps solve your IT challenges through an onsite, multi-day session with a Lenovo technology expert. We perform a tools-based assessment which provides a comprehensive and thorough review of a company's environment and technology systems. In addition to the technology based functional requirements, the consultant also discusses and records the non-functional business requirements, challenges, and constraints. Assessments help organizations like yours, no matter how large or small, get a better return on your IT investment and overcome challenges in the ever-changing technology landscape.

- **Design Services**

Professional Services consultants perform infrastructure design and implementation planning to support your strategy. The high-level architectures provided by the assessment service are turned into low level designs and wiring diagrams, which are reviewed and approved prior to implementation. The implementation plan will demonstrate an outcome-based proposal to provide business capabilities through infrastructure with a risk-mitigated project plan.

- **Basic Hardware Installation**

Lenovo experts can seamlessly manage the physical installation of your server, storage, or networking hardware. Working at a time convenient for you (business hours or off shift), the technician will unpack and inspect the systems on your site, install options, mount in a rack cabinet, connect to power and network, check and update firmware to the latest levels, verify operation, and dispose of the packaging, allowing your team to focus on other priorities.

- **Deployment Services**

When investing in new IT infrastructures, you need to ensure your business will see quick time to value with little to no disruption. Lenovo deployments are designed by development and engineering teams who know our Products & Solutions better than anyone else, and our technicians own the process from delivery to completion. Lenovo will conduct remote preparation and planning, configure & integrate systems, validate systems, verify and update appliance firmware, train on administrative tasks, and provide post-deployment documentation. Customer's IT teams leverage our skills to enable IT staff to transform with higher level roles and tasks.

- **Integration, Migration, and Expansion Services**

Move existing physical & virtual workloads easily, or determine technical requirements to support increased workloads while maximizing performance. Includes tuning, validation, and documenting ongoing run processes. Leverage migration assessment planning documents to perform necessary migrations.

- **Data Center Power and Cooling Services**

The Data Center Infrastructure team will provide solution design and implementation services to support the power and cooling needs of the multi-node chassis and multi-rack solutions. This includes designing for various levels of power redundancy and integration into the customer power infrastructure. The Infrastructure team will work with site engineers to design an effective cooling strategy based on facility constraints or customer goals and optimize a cooling solution to ensure high efficiency and availability. The Infrastructure team will provide the detailed solution design and complete integration of the cooling solution into the customer data center. In addition, the Infrastructure team will provide rack and chassis level commissioning and stand-up of the water-cooled solution which includes setting and tuning of the flow rates based on water temperature and heat recovery targets. Lastly, the Infrastructure team will provide cooling solution optimization and performance validation to ensure the highest overall operational efficiency of the solution.

Rack cabinets

The DW612S enclosure is supported in the following racks:

- Lenovo EveryScale 42U Onyx Heavy Duty Rack Cabinet, model 1410-O42
- Lenovo EveryScale 42U Pearl Heavy Duty Rack Cabinet, model 1410-P42
- Lenovo EveryScale 48U Onyx Heavy Duty Rack Cabinet, model 1410-O48
- Lenovo EveryScale 48U Pearl Heavy Duty Rack Cabinet, model 1410-P48

Considering the weight of the trays in the enclosure, an onsite material lift is required to allow service by a single person. If you do not already have a material lift available, Lenovo offers the Genie Lift GL-8 material lift as configurable option to the rack cabinets. Ordering information is listed in the following table.

Table 53. Genie Lift GL-8 ordering information

Model	Description
7D5YCTO1WW	Genie Lift GL-8 Material Lift

Lenovo Financial Services

Lenovo Financial Services reinforces Lenovo’s commitment to deliver pioneering products and services that are recognized for their quality, excellence, and trustworthiness. Lenovo Financial Services offers financing solutions and services that complement your technology solution anywhere in the world.

We are dedicated to delivering a positive finance experience for customers like you who want to maximize your purchase power by obtaining the technology you need today, protect against technology obsolescence, and preserve your capital for other uses.

We work with businesses, non-profit organizations, governments and educational institutions to finance their entire technology solution. We focus on making it easy to do business with us. Our highly experienced team of finance professionals operates in a work culture that emphasizes the importance of providing outstanding customer service. Our systems, processes and flexible policies support our goal of providing customers with a positive experience.

We finance your entire solution. Unlike others, we allow you to bundle everything you need from hardware and software to service contracts, installation costs, training fees, and sales tax. If you decide weeks or months later to add to your solution, we can consolidate everything into a single invoice.

Our Premier Client services provide large accounts with special handling services to ensure these complex transactions are serviced properly. As a premier client, you have a dedicated finance specialist who manages your account through its life, from first invoice through asset return or purchase. This specialist develops an in-depth understanding of your invoice and payment requirements. For you, this dedication provides a high-quality, easy, and positive financing experience.

For your region-specific offers, please ask your Lenovo sales representative or your technology provider about the use of Lenovo Financial Services. For more information, see the following Lenovo website:

<https://www.lenovo.com/us/en/landingpage/lenovo-financial-services/>

Seller training courses

The following sales training courses are offered for employees and partners (login required). Courses are listed in date order.

1. Family Introduction ThinkSystem Supercomputing Servers

2024-02-21 | 10 minutes | Employees and Partners

After completing this introductory course about the supercomputing server family, the learner will be able to define the characteristics of high-density servers, describe the supercomputing servers, recognize when a product from the supercomputing server family might be used, and identify keywords or buzzwords that indicate opportunities to introduce customers to the supercomputing server family products.

Published: 2024-02-21

Length: 10 minutes

Employee link: [Grow@Lenovo](#)

Partner link: [Lenovo Partner Learning](#)

Course code: SXXW2526

2. Intel Transparent Supply Chain on Lenovo Servers

2024-01-29 | 12 minutes | Employees and Partners

This course introduces the Intel Transparent Supply Chain (TSC) program, explains how the program works, and discusses the benefits of the Intel TSC program to customers. Adding the Intel TSC feature to an order is explained.

Course objectives:

- Describe the Intel® Transparent Supply Chain program
- Explain how the Intel® Transparent Supply Chain program works
- Discuss the benefits of the Intel® Transparent Supply Chain program to Lenovo customers
- Explain how to add Intel® Transparent Supply Chain program feature to an order

Published: 2024-01-29

Length: 12 minutes

Employee link: [Grow@Lenovo](#)

Partner link: [Lenovo Partner Learning](#)

Course code: SXXW1230

3. Family Portfolio: Storage Controller Options

2024-01-23 | 25 minutes | Employees and Partners

This course covers the storage controller options available for use in Lenovo servers. The classes of storage controller are discussed, along with a discussion of where they are used, and which to choose.

After completing this course, you will be able to:

- Describe the classes of storage controllers
- Discuss where each controller class is used
- Describe the available options in each controller class

Published: 2024-01-23

Length: 25 minutes

Employee link: [Grow@Lenovo](#)

Partner link: [Lenovo Partner Learning](#)

Course code: SXXW1111

4. Lenovo-Intel Sustainable Solutions QH
2024-01-22 | 10 minutes | Employees and Partners

This Quick Hit explains how Lenovo and Intel are committed to sustainability, and introduces the Lenovo-Intel joint sustainability campaign. You will learn how to use this campaign to show customers what that level of commitment entails, how to use the campaign's unsolicited proposal approach, and how to use the campaign as a conversation starter which may lead to increased sales.

Published: 2024-01-22
Length: 10 minutes
Employee link: [Grow@Lenovo](#)
Partner link: [Lenovo Partner Learning](#)
Course code: SXXW2524a

5. Family Portfolio Intel Supercomputing Servers
2024-01-12 | 15 minutes | Employees and Partners

This course covers the Intel-based 6U12N server family, formerly part of the Dense server family. After completing this course about the Intel® supercomputing server family, you will be able to identify products and features within the family, describe the customer benefits of this product family, and recognize when a specific product or products should be selected.

Published: 2024-01-12
Length: 15 minutes
Employee link: [Grow@Lenovo](#)
Partner link: [Lenovo Partner Learning](#)
Course code: SXXW2519

6. FY24Q3 Intel Servers Update
2023-12-11 | 15 minutes | Employees and Partners

This update is designed to help you discuss the features and customer benefits of Lenovo servers that use the 5th Gen Intel® Xeon® processors. Lenovo has also introduced a new server, the ThinkSystem SD650-N V3, which expands the supercomputer server family. Reasons to call your customer and talk about refreshing their infrastructure are also included as a guideline.

Published: 2023-12-11
Length: 15 minutes
Employee link: [Grow@Lenovo](#)
Partner link: [Lenovo Partner Learning](#)
Course code: SXXW2522a

7. Partner Technical Webinar - Neptune Liquid Cooling
2023-10-24 | 60 minutes | Employees and Partners

In this 60-minute replay, Matt Ziegler, Lenovo Principal Architect for Neptune and Sustainability, discussed the data center power and cooling challenges, the increasing demands of processors and Lenovo's Neptune Liquid Cooling Technology.

Published: 2023-10-24
Length: 60 minutes
Employee link: [Grow@Lenovo](#)
Partner link: [Lenovo Partner Learning](#)
Course code: 102023

8. Lenovo Data Center Product Portfolio
2023-07-21 | 15 minutes | Employees and Partners

This course introduces the Lenovo data center portfolio, and covers servers, storage, storage networking, and software-defined infrastructure products. After completing this course about Lenovo data center products, you will be able to identify product types within each data center family, describe Lenovo innovations that this product family or category uses, and recognize when a specific product should be selected.

Published: 2023-07-21
Length: 15 minutes
Employee link: [Grow@Lenovo](#)
Partner link: [Lenovo Partner Learning](#)
Course code: SXXW1110r6

9. Partner Technical Webinar - Data Center Limits and ISG TAA Compliance
2023-05-16 | 60 minutes | Employees and Partners

In this 60-minute replay, we had two topics. First Vinod Kamath, Lenovo Distinguished Engineer for Data Center Cooling presented on the Systems Configuration and Data Center Ambient Limits. Second, Shama Patari, Lenovo Trade Council, and Glenn Johnson, Lenovo Principal Engineer for Supply Chain presented on ISG TAA Compliance.

Published: 2023-05-16
Length: 60 minutes
Employee link: [Grow@Lenovo](#)
Partner link: [Lenovo Partner Learning](#)
Course code: 051223

10. Family Portfolio: Intel Dense Servers
2023-01-05 | 10 minutes | Employees and Partners

This course is designed to give Lenovo sales and partner representatives a foundation for the Intel Dense server family products.

After completing this course, you will be able to identify products and features within the family, describe Lenovo innovations that this product family uses, and recognize when a specific product or products should be selected.

Published: 2023-01-05
Length: 10 minutes
Employee link: [Grow@Lenovo](#)
Partner link: [Lenovo Partner Learning](#)
Course code: SXXW1211r8

11. Family Portfolio Intel Dense Servers V3 Preview
2023-01-04 | 3 minutes | Employees and Partners

This Quick Hit introduces three new servers, the SD630 V3, SD650 V3, and SD650-I V3 and a new enclosure, the DW612S, in the ThinkSystem Intel Dense server family, and introduces new features. Note: This course is presented as audio only. There are no slides or video.

Published: 2023-01-04
Length: 3 minutes
Employee link: [Grow@Lenovo](#)
Partner link: [Lenovo Partner Learning](#)
Course code: SXXW1211r8a

12. **Lenovo Infrastructure Solutions Launch**
2022-09-16 | 8 minutes | Employees and Partners

This Quick Hit introduces a wealth of new products, solutions, and services announced as part of the Lenovo ThinkSystem 30th Anniversary celebration.

Published: 2022-09-16
Length: 8 minutes
Employee link: [Grow@Lenovo](#)
Partner link: [Lenovo Partner Learning](#)
Course code: FY23Q2a

13. **Neptune Direct Water Cooling Preview**
2022-09-16 | 3 minutes | Employees and Partners

This Quick Hit introduces the 5th Generation Lenovo Neptune cooling solutions. An industry leader in liquid cooling, Lenovo Neptune delivers alternative cooling solutions that range from liquid-assisted air cooling to direct water-cooled CPUs and GPUs.

Published: 2022-09-16
Length: 3 minutes
Employee link: [Grow@Lenovo](#)
Partner link: [Lenovo Partner Learning](#)
Course code: SXXW2509a

14. **Lenovo Sustainable Computing**
2022-09-16 | 4 minutes | Employees and Partners

This Quick Hit describes the Lenovo sustainable computing program, and the many ways in which Lenovo strives to respect and protect the environment.

Published: 2022-09-16
Length: 4 minutes
Employee link: [Grow@Lenovo](#)
Partner link: [Lenovo Partner Learning](#)
Course code: SXXW2504a

15. **Introduction to DDR5 Memory**
2022-08-23 | 10 minutes | Employees and Partners

This course introduces DDR5 memory, describes new features of this memory generation, and discusses the advantages to customers of this new memory generation.

Published: 2022-08-23
Length: 10 minutes
Employee link: [Grow@Lenovo](#)
Partner link: [Lenovo Partner Learning](#)
Course code: SXXW2502

Related publications and links

For more information, see these resources:

- ThinkSystem SD650 V3 product page
<https://www.lenovo.com/us/en/p/high-density/len21ts0014>
- ThinkSystem SD665 V3 datasheet
<https://lenovopress.com/DS0146>
- Interactive 3D Tour of the ThinkSystem SD650 V3:
<https://lenovopress.lenovo.com/lp1623-thinksystem-sd650-v3-interactive-3d-tour>
- ThinkSystem SD650 V3 drivers and support
<http://datacentersupport.lenovo.com/products/servers/thinksystem/sd650v3/7d7m/downloads>
- Lenovo Hardware Installation & Removal Videos on the ThinkSystem DW612S Enclosure:
<https://www.youtube.com/playlist?list=PLYV5R7hVcs-A9Ws8PYIbxz9Jblrq1zoYd>
- Lenovo ThinkSystem SD650 V3 product publications:
<https://pubs.lenovo.com/sd650-v3/>
 - Quick Start
 - Rack Installation Guide
 - Setup Guide
 - Maintenance Manual
 - Messages and Codes Reference
 - UEFI Manual
- ServerProven hardware compatibility:
<https://serverproven.lenovo.com/>
- Data Center Solution Configurator (DCSC)
<https://dcsc.lenovo.com>
- Lenovo Cluster solutions configurator (x-config)
<https://lesc.lenovo.com/products/hardware/configurator/worldwide/bhui/asit/index.html>

Related product families

Product families related to this document are the following:

- [Artificial Intelligence](#)
- [High Performance Computing](#)
- [Supercomputing Servers](#)
- [ThinkSystem SD650 V3 server](#)

Notices

Lenovo may not offer the products, services, or features discussed in this document in all countries. Consult your local Lenovo representative for information on the products and services currently available in your area. Any reference to a Lenovo product, program, or service is not intended to state or imply that only that Lenovo product, program, or service may be used. Any functionally equivalent product, program, or service that does not infringe any Lenovo intellectual property right may be used instead. However, it is the user's responsibility to evaluate and verify the operation of any other product, program, or service. Lenovo may have patents or pending patent applications covering subject matter described in this document. The furnishing of this document does not give you any license to these patents. You can send license inquiries, in writing, to:

Lenovo (United States), Inc.
8001 Development Drive
Morrisville, NC 27560
U.S.A.

Attention: Lenovo Director of Licensing

LENOVO PROVIDES THIS PUBLICATION "AS IS" WITHOUT WARRANTY OF ANY KIND, EITHER EXPRESS OR IMPLIED, INCLUDING, BUT NOT LIMITED TO, THE IMPLIED WARRANTIES OF NON-INFRINGEMENT, MERCHANTABILITY OR FITNESS FOR A PARTICULAR PURPOSE. Some jurisdictions do not allow disclaimer of express or implied warranties in certain transactions, therefore, this statement may not apply to you.

This information could include technical inaccuracies or typographical errors. Changes are periodically made to the information herein; these changes will be incorporated in new editions of the publication. Lenovo may make improvements and/or changes in the product(s) and/or the program(s) described in this publication at any time without notice.

The products described in this document are not intended for use in implantation or other life support applications where malfunction may result in injury or death to persons. The information contained in this document does not affect or change Lenovo product specifications or warranties. Nothing in this document shall operate as an express or implied license or indemnity under the intellectual property rights of Lenovo or third parties. All information contained in this document was obtained in specific environments and is presented as an illustration. The result obtained in other operating environments may vary. Lenovo may use or distribute any of the information you supply in any way it believes appropriate without incurring any obligation to you.

Any references in this publication to non-Lenovo Web sites are provided for convenience only and do not in any manner serve as an endorsement of those Web sites. The materials at those Web sites are not part of the materials for this Lenovo product, and use of those Web sites is at your own risk. Any performance data contained herein was determined in a controlled environment. Therefore, the result obtained in other operating environments may vary significantly. Some measurements may have been made on development-level systems and there is no guarantee that these measurements will be the same on generally available systems. Furthermore, some measurements may have been estimated through extrapolation. Actual results may vary. Users of this document should verify the applicable data for their specific environment.

© Copyright Lenovo 2024. All rights reserved.

This document, LP1603, was created or updated on December 14, 2023.

Send us your comments in one of the following ways:

- Use the online Contact us review form found at:
<https://lenovopress.lenovo.com/LP1603>
- Send your comments in an e-mail to:
comments@lenovopress.com

This document is available online at <https://lenovopress.lenovo.com/LP1603>.

Trademarks

Lenovo and the Lenovo logo are trademarks or registered trademarks of Lenovo in the United States, other countries, or both. A current list of Lenovo trademarks is available on the Web at <https://www.lenovo.com/us/en/legal/copytrade/>.

The following terms are trademarks of Lenovo in the United States, other countries, or both:

Lenovo®
Bootable Media Creator
Flex System
from Exascale to Everscale
Lenovo Neptune®
Lenovo Services
ServerProven®
System x®
ThinkShield®
ThinkServer®
ThinkSystem®
UpdateXpress System Packs
XClarity®

The following terms are trademarks of other companies:

Intel® and Xeon® are trademarks of Intel Corporation or its subsidiaries.

Linux® is the trademark of Linus Torvalds in the U.S. and other countries.

Microsoft®, ActiveX®, PowerShell, Windows PowerShell®, and Windows® are trademarks of Microsoft Corporation in the United States, other countries, or both.

SPECpower® is a trademark of the Standard Performance Evaluation Corporation (SPEC).

Other company, product, or service names may be trademarks or service marks of others.