

# H3C S6850 & S9850 Switch Series

## Installation Guide

**Copyright © 2018, 2022 New H3C Technologies Co., Ltd. and its licensors**

**All rights reserved**

No part of this manual may be reproduced or transmitted in any form or by any means without prior written consent of New H3C Technologies Co., Ltd.

**Trademarks**

Except for the trademarks of New H3C Technologies Co., Ltd., any trademarks that may be mentioned in this document are the property of their respective owners.

**Notice**

The information in this document is subject to change without notice. All contents in this document, including statements, information, and recommendations, are believed to be accurate, but they are presented without warranty of any kind, express or implied. H3C shall not be liable for technical or editorial errors or omissions contained herein.

**Environmental protection**

This product has been designed to comply with the environmental protection requirements. The storage, use, and disposal of this product must meet the applicable national laws and regulations.

# Preface

H3C S6850&S9850 Switch Series Installation Guide describes the installation, power-on, maintenance, and troubleshooting of the H3C S6850&S9850 Switch Series.

This preface includes the following topics about the documentation:

- [Audience](#).
- [Conventions](#).
- [Documentation feedback](#).

## Audience

This documentation is intended for:

- Network planners.
- Field technical support and servicing engineers.
- Network administrators working with the S6850&S9850 switch series.

## Conventions

The following information describes the conventions used in the documentation.





### Command conventions

Convention	Description
<b>Boldface</b>	<b>Bold</b> text represents commands and keywords that you enter literally as shown.
<i>Italic</i>	<i>Italic</i> text represents arguments that you replace with actual values.
[ ]	Square brackets enclose syntax choices (keywords or arguments) that are optional.
{ x   y   ... }	Braces enclose a set of required syntax choices separated by vertical bars, from which you select one.
[ x   y   ... ]	Square brackets enclose a set of optional syntax choices separated by vertical bars, from which you select one or none.
{ x   y   ... }*	Asterisk marked braces enclose a set of required syntax choices separated by vertical bars, from which you select a minimum of one.
[ x   y   ... ]*	Asterisk marked square brackets enclose optional syntax choices separated by vertical bars, from which you select one choice, multiple choices, or none.
&<1-n>	The argument or keyword and argument combination before the ampersand (&) sign can be entered 1 to n times.
#	A line that starts with a pound (#) sign is comments.













### GUI conventions

Convention	Description
<b>Boldface</b>	Window names, button names, field names, and menu items are in Boldface. For example, the <b>New User</b> window opens; click <b>OK</b> .
>	Multi-level menus are separated by angle brackets. For example, <b>File &gt; Create &gt; Folder</b> .

## Symbols

Convention	Description
 <b>WARNING!</b>	An alert that calls attention to important information that if not understood or followed can result in personal injury.
 <b>CAUTION:</b>	An alert that calls attention to important information that if not understood or followed can result in data loss, data corruption, or damage to hardware or software.
 <b>IMPORTANT:</b>	An alert that calls attention to essential information.
<b>NOTE:</b>	An alert that contains additional or supplementary information.
 <b>TIP:</b>	An alert that provides helpful information.

## Network topology icons

Convention	Description
	Represents a generic network device, such as a router, switch, or firewall.
	Represents a routing-capable device, such as a router or Layer 3 switch.
	Represents a generic switch, such as a Layer 2 or Layer 3 switch, or a router that supports Layer 2 forwarding and other Layer 2 features.
	Represents an access controller, a unified wired-WLAN module, or the access controller engine on a unified wired-WLAN switch.
	Represents an access point.
	Represents a wireless terminator unit.
	Represents a wireless terminator.
	Represents a mesh access point.
	Represents omnidirectional signals.
	Represents directional signals.
	Represents a security product, such as a firewall, UTM, multiservice security gateway, or load balancing device.
	Represents a security module, such as a firewall, load balancing, NetStream, SSL VPN, IPS, or ACG module.

## Examples provided in this document

Examples in this document might use devices that differ from your device in hardware model, configuration, or software version. It is normal that the port numbers, sample output, screenshots, and other information in the examples differ from what you have on your device.



# Documentation feedback

You can e-mail your comments about product documentation to [info@h3c.com](mailto:info@h3c.com).

We appreciate your comments.

# Contents

<b>1</b>	<b>Preparing for installation</b>	<b>1</b>
	Safety recommendations	1
	Examining the installation site	1
	Temperature/humidity	2
	Cleanliness	2
	EMI	3
	Laser safety	3
	Installation tools	3
<b>2</b>	<b>Installing the switch</b>	<b>2-4</b>
	Installing the switch in a 19-inch rack	2-5
	Rack-mounting procedures at a glance	2-5
	Rack-mounting requirements	2-5
	Installation accessories	2-9
	Mounting brackets, chassis rails, and grounding cable installation positions	2-12
	Attaching the mounting brackets and chassis rails to the chassis	2-14
	Connecting the grounding cable to the chassis	2-20
	Attaching the slide rails to the rack	2-21
	Mounting the switch in the rack	2-22
	Grounding the switch	2-27
	Installing/removing fan trays	2-28
	Installing a fan tray	2-28
	Removing a fan tray	2-29
	Installing/removing power modules	2-30
	Installing a power module	2-30
	Removing a power module	2-32
	Connecting the power cords	2-33
	Connecting an AC power cord	2-33
	Connecting a DC power cord	2-34
	Installing/removing expansion modules	2-35
	Installing an expansion module	2-35
	Removing an expansion module	2-36
	Verifying the installation	2-37
<b>3</b>	<b>Accessing the switch for the first time</b>	<b>3-38</b>
	Setting up the configuration environment	3-38
	Connecting the console cable	3-38
	Connecting the mini USB console cable	3-39
	Setting terminal parameters	3-41
	Powering on the switch	3-41
<b>4</b>	<b>Setting up an IRF fabric</b>	<b>4-43</b>
	IRF fabric setup flowchart	4-43
	Planning IRF fabric setup	4-44
	Planning IRF fabric size and the installation site	4-44
	Identifying the master switch and planning IRF member IDs	4-44
	Planning IRF topology and connections	4-45
	Identifying physical IRF ports on the member switches	4-46
	Planning the cabling scheme	4-47
	Configuring basic IRF settings	4-48
	Connecting the physical IRF ports	4-48
	Accessing the IRF fabric to verify the configuration	4-49
<b>5</b>	<b>Maintenance and troubleshooting</b>	<b>5-50</b>
	Power module failure	5-50
	Symptom	5-50
	Solution	5-50

Fan tray failure .....	5-50
Symptom .....	5-50
Solution .....	5-50
Configuration terminal display problems .....	5-51
No display .....	5-51
Garbled display .....	5-51

# 1 Preparing for installation

The H3C S6850 Switch Series and S9850 Switch Series are high-density intelligent 100G access switches with powerful hardware forwarding capacity and abundant data center features. They are developed for data centers and high-end campus networks.

The H3C S6850 Switch Series includes the following models:

- S6850-56HF
- S6850-2C

The H3C S9850 Switch Series includes the following models:

- S9850-4C
- S9850-32H

The switch supports the following ports and FRUs:

- 100G QSFP28 ports, 40G QSFP+ ports, 25GE SFP28 ports, and 10G SFP+ ports.
- Two 1G management Ethernet ports (one fiber port and one copper port).
- Removable fan trays in redundancy mode and flexible airflows.
- Removable power modules in redundancy mode.

## Safety recommendations

To avoid any equipment damage or bodily injury caused by incorrect use, read the following safety recommendations before installation. Note that the recommendations do not cover every possible hazardous condition.

- Before cleaning the switch, remove all power cords from the switch. Do not clean the switch with wet cloth or liquid.
- Do not place the switch near water or in a damp environment. Prevent water or moisture from entering the switch chassis.
- Do not place the switch on an unstable case or desk. The switch might be severely damaged in case of a fall.
- Ensure good ventilation of the equipment room and keep the air inlet and outlet vents of the switch free of obstruction.
- Connect the yellow-green protection grounding cable before power-on.
- Make sure the operating voltage is in the required range.
- To avoid electrical shocks, do not open the chassis while the switch is operating or when the switch is just powered off.
- When replacing field replaceable units (FRUs), including power modules and fan trays, wear an ESD wrist strap to avoid damaging the units.

## Examining the installation site

The switch must be used indoors.

Mount your switch in a rack and verify the following items:

- Adequate clearance is reserved at the air inlet and outlet vents for ventilation.
- The rack has a good ventilation system.

- Identify the hot aisle and cold aisle at the installation site, and make sure ambient air flows into the switch from the cold aisle and exhausts to the hot aisle.
- Identify the airflow designs of neighboring devices, and prevent hot air flowing out of the neighboring devices from entering the top device.
- The rack is sturdy enough to support the switch and its accessories.
- The rack is reliably grounded.

To ensure correct operation and long service life of your switch, install it in an environment that meets the requirements described in the following subsections.

## Temperature/humidity

Maintain appropriate temperature and humidity in the equipment room.

- Lasting high relative humidity can cause poor insulation, electricity leakage, mechanical property change of materials, and metal corrosion.
- Lasting low relative humidity can cause washer contraction and ESD and cause problems including loose mounting screws and circuit failure.
- High temperature can accelerate the aging of insulation materials and significantly lower the reliability and lifespan of the switch.

For the temperature and humidity requirements for the switch, see *H3C S6850 & S9850 Switch Series Hardware Information and Specifications*.

## Cleanliness

Dust buildup on the chassis might result in electrostatic adsorption, which causes poor contact of metal components and contact points. In the worst case, this might shorten the device's lifetime and even cause communication failure. [Table1-1](#) describes the dust concentration limits in the equipment room.

**Table1-1 Dust concentration limit in the equipment room**

Substance	Particle diameter	Concentration limit
Dust particles	≥ 0.5 μm	≤ 3.5 × 10 <sup>6</sup> particles/m <sup>3</sup>
Dust particles	≥ 5 μm	≤ 3 × 10 <sup>4</sup> particles/m <sup>3</sup>
Dust (suspension)	≤ 75 μm	≤ 0.2 mg/m <sup>3</sup>
Dust (sedimentation)	75 μm to 150 μm	≤ 1.5 mg/(m <sup>2</sup> h)

Corrosive gases can accelerate corrosion and aging of metal components. Make sure the corrosive gases in the equipment room do not exceed the concentration limits as shown in [Table1-2](#).

**Table1-2 Harmful gas limits in the equipment room**

Gas	Average concentration (mg/m <sup>3</sup> )	Maximum concentration (mg/m <sup>3</sup> )
SO <sub>2</sub>	0.3	1.0
H <sub>2</sub> S	0.1	0.5
Cl <sub>2</sub>	0.1	0.3
HCl	0.1	0.5
HF	0.01	0.03

Gas	Average concentration (mg/m <sup>3</sup> )	Maximum concentration (mg/m <sup>3</sup> )
NH <sub>3</sub>	1.0	3.0
O <sub>3</sub>	0.05	0.1
NO <sub>x</sub>	0.5	1.0

## EMI

All electromagnetic interference (EMI) sources, from outside or inside of the switch and application system, adversely affect the switch in the following ways:

- A conduction pattern of capacitance coupling.
- Inductance coupling.
- Electromagnetic wave radiation.
- Common impedance (including the grounding system) coupling.

To prevent EMI, use the following guidelines:

- If AC power is used, use a single-phase three-wire power receptacle with protection earth (PE) to filter interference from the power grid.
- Keep the switch far away from radio transmitting stations, radar stations, and high-frequency devices.
- Use electromagnetic shielding, for example, shielded interface cables, when necessary.
- To prevent signal ports from getting damaged by overvoltage or overcurrent caused by lightning strikes, route interface cables only indoors.

## Laser safety

---

### **WARNING!**

- The switch is a Class 1M laser device.
  - Disconnected optical fibers or transceiver modules might emit invisible laser light. Do not stare into beams or view directly with optical instruments when the switch is operating.
- 

## Installation tools

No installation tools are provided with the switch. Prepare the following tools yourself:

- Phillips screwdriver.
- ESD wrist strap.
- Marker.

# 2 Installing the switch

**△ CAUTION:**

Keep the tamper-proof seal on a mounting screw on the chassis cover intact, and if you want to open the chassis, contact H3C for permission. Otherwise, H3C shall not be liable for any consequence caused thereby.

**Figure2-1 Hardware installation flow**

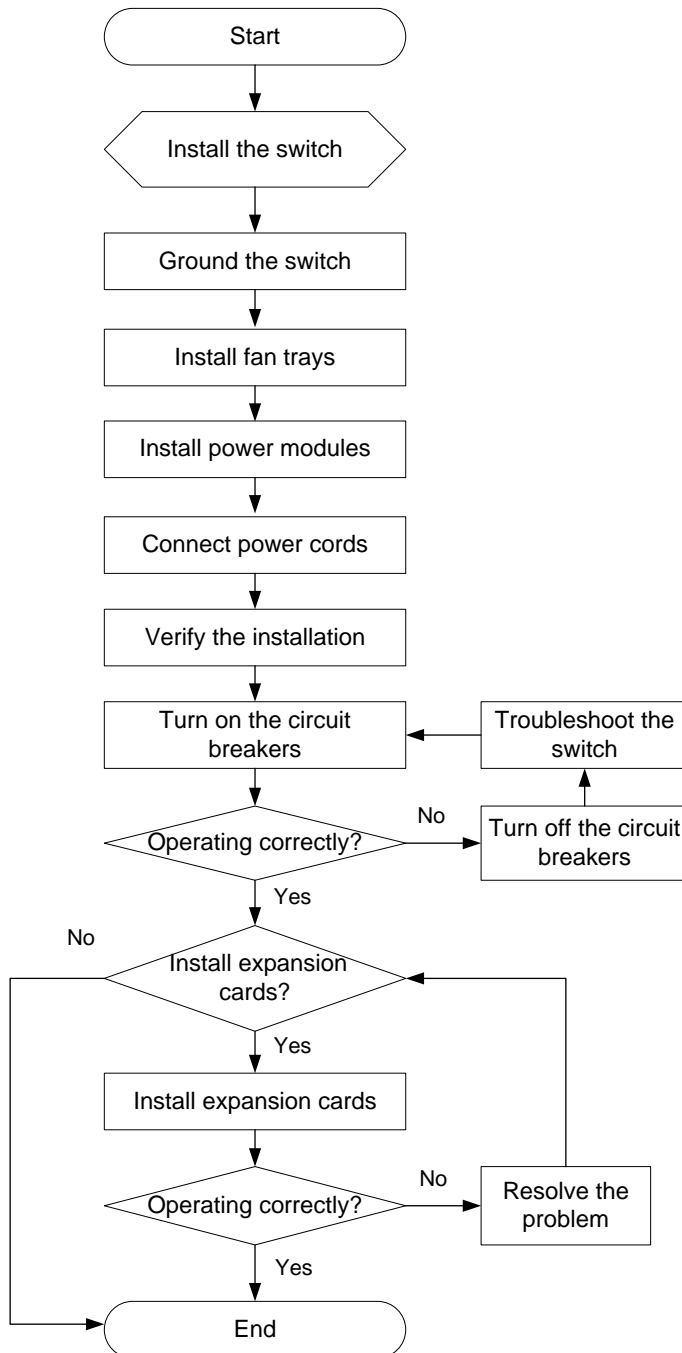

# Installing the switch in a 19-inch rack

## Rack-mounting procedures at a glance

**Figure2-2 Rack-mounting procedure**

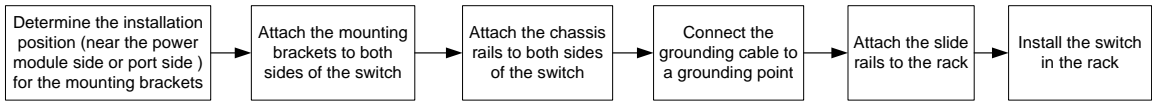

**NOTE:**

If a rack shelf is available, you can put the switch on the rack shelf and slide the switch to a position so that the mounting brackets make close contact with the front rack posts. Then use screws to secure the mounting brackets to the rack.

## Rack-mounting requirements

**Figure2-3 S6850-56HF chassis dimensions (mounting brackets installed at the port side, left-side view)**

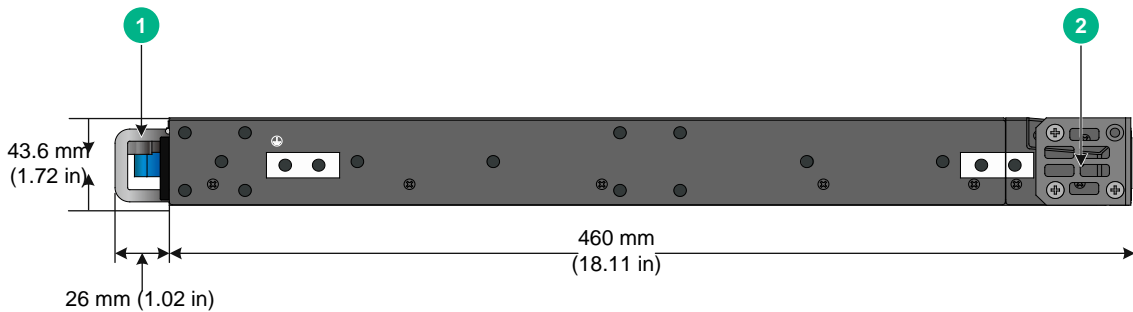

(1) Power module handle

(2) Mounting bracket

**Figure2-4 S6850-56HF chassis dimensions (mounting brackets installed at the power module side, left-side view)**

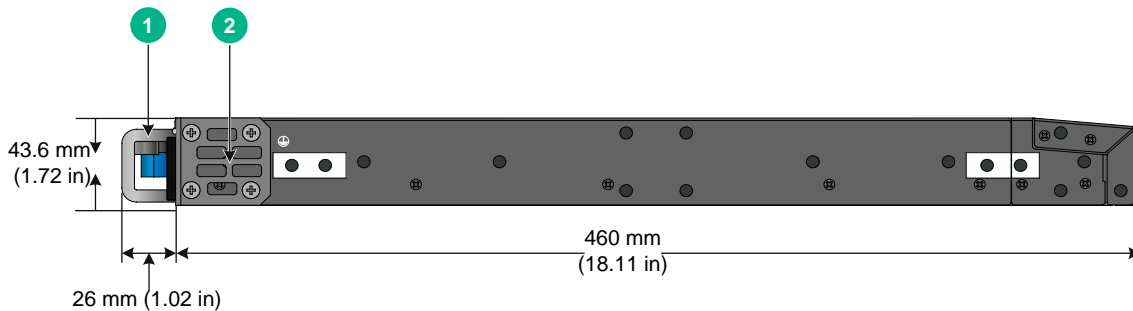

(1) Power module handle

(2) Mounting bracket



**Figure2-5 S6850-2C chassis dimensions (mounting brackets installed at the port side, left-side view)**

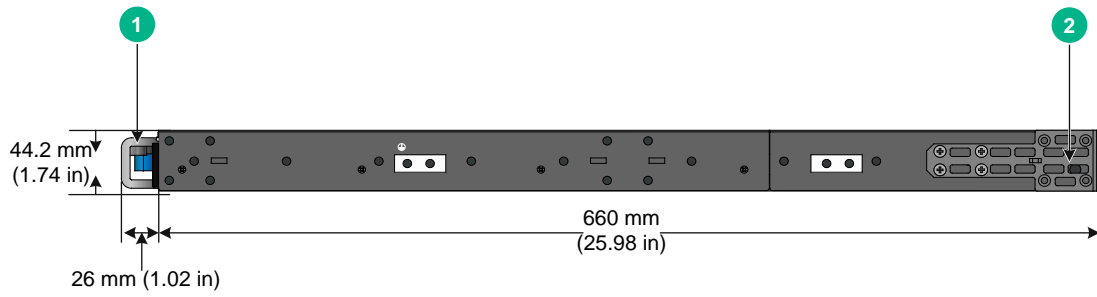

(1) Power module handle

(2) Mounting bracket

**Figure2-6 S6850-2C chassis dimensions (mounting brackets installed at the power module side, left-side view)**

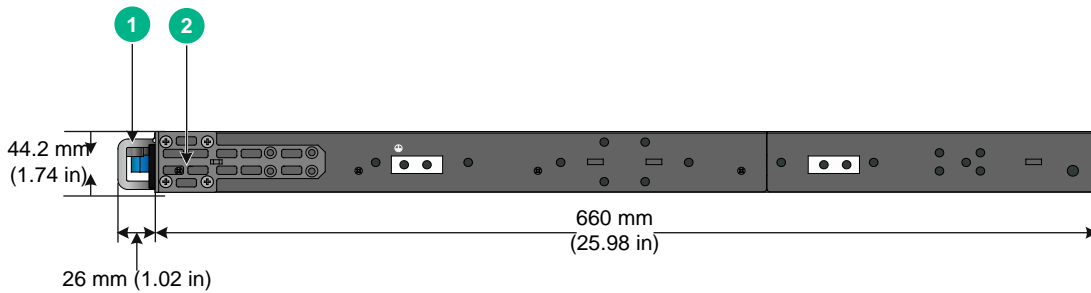

(1) Power module handle

(2) Mounting bracket

**Figure2-7 S9850-4C chassis dimensions (mounting brackets installed at the port side, left-side view)**

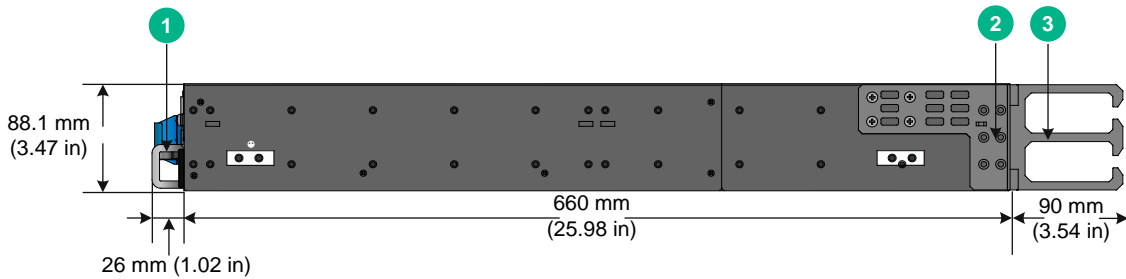

(1) Power module handle

(2) Mounting bracket

(3) Cable management bracket

**Figure2-8 S9850-4C chassis dimensions (mounting brackets installed at the power module side, left-side view)**

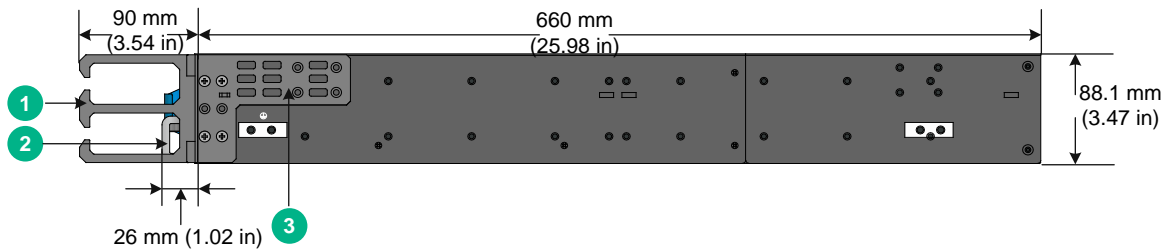

- 
- (1) Cable management bracket
  - (2) Power module handle
- 
- (3) Mounting bracket
- 

**Figure2-9 S9850-32H chassis dimensions (mounting brackets installed at the port side, left-side view)**

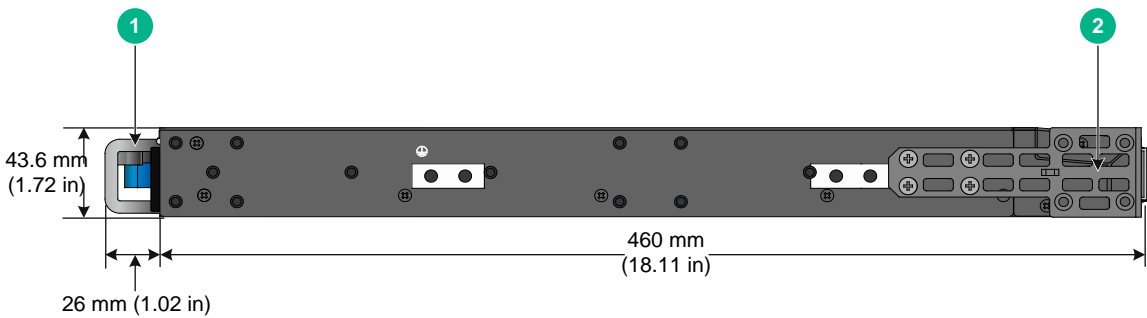

- 
- (1) Power module handle
  - (2) Mounting bracket
- 

**Figure2-10 S9850-32H chassis dimensions (mounting brackets installed at the power module side, left-side view)**

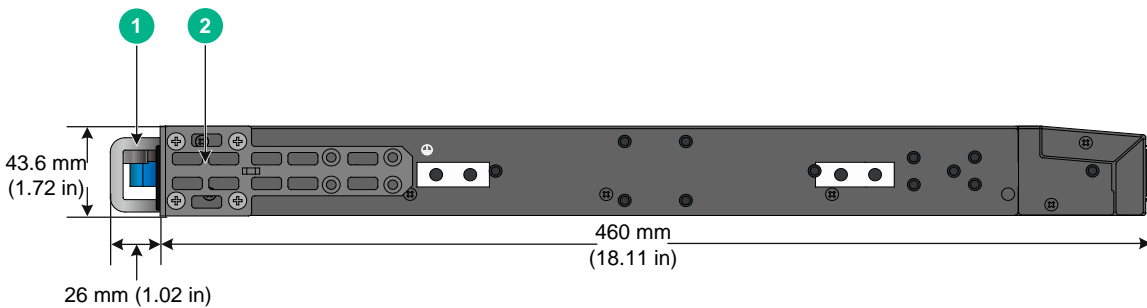

- 
- (1) Power module handle
  - (2) Mounting bracket
- 

**Table2-2 Distance requirements between the front and rear rack posts**

Switch model	Installation method	Chassis dimensions	Distance between the front and rear rack posts	Rack requirements
S6850-56 HF	Mounting brackets and long slide rails (provided)	<ul style="list-style-type: none"> <li>• <b>Height</b>—43.6 mm (1.72 in)/1 RU</li> <li>• <b>Width</b>—440 mm</li> </ul>	692 to 853 mm (27.24 to 33.58 in)	<ul style="list-style-type: none"> <li>• A minimum of 800 mm (31.50 in) in depth</li> </ul>

Switch model	Installation method	Chassis dimensions	Distance between the front and rear rack posts	Rack requirements
	Mounting brackets and super-short slide rails (optional, chassis rails not reaching out of the chassis)	(17.32 in) <ul style="list-style-type: none"> <li>• <b>Depth</b>—486 mm (19.13 in) <ul style="list-style-type: none"> <li>○ 460 mm (18.11 in) for the chassis</li> <li>○ 26 mm (1.02 in) for the power module/fan tray handles</li> </ul> </li> </ul>	401 to 565 mm (15.79 to 22.24 in)	(recommended) <ul style="list-style-type: none"> <li>• A minimum of 130 mm (5.12 in) between the front rack post and the front door.</li> <li>• A minimum of 550 mm (21.65 in) between the front rack post and the rear door.</li> </ul>
	Mounting brackets and super-short slide rails (optional, chassis rails reaching out of the chassis)		499 to 692 mm (19.65 to 27.24 in)	
S6850-2C	Mounting brackets at the port side	<ul style="list-style-type: none"> <li>• <b>Height</b>—44.2 mm (1.74 in)/1 RU</li> <li>• <b>Width</b>—440 mm (17.32 in)</li> <li>• <b>Depth</b>—686 mm (27.01 in) <ul style="list-style-type: none"> <li>○ 660 mm (25.98 in) for the chassis</li> <li>○ 26 mm (1.02 in) for the power module/fan tray handles</li> </ul> </li> </ul>	519 to 768 mm (20.43 to 30.24 in)	<ul style="list-style-type: none"> <li>• A minimum of 1000 mm (39.37 in) in depth (recommended)</li> <li>• A minimum of 130 mm (5.12 in) between the front rack post and the front door.</li> <li>• A minimum of 750 mm (29.53 in) between the front rack post and the rear door.</li> </ul>
	Mounting brackets at the power module side			
S9850-4C	Mounting brackets at the port side	<ul style="list-style-type: none"> <li>• <b>Height</b>—88.1 mm (3.47 in)/2 RU</li> <li>• <b>Width</b>—440 mm (17.32 in)</li> <li>• <b>Depth</b>—776 mm (33.55 in) <ul style="list-style-type: none"> <li>○ 660 mm (25.98 in) for the chassis</li> <li>○ 26 mm (1.02 in) for the power module/fan tray handles</li> <li>○ 90 mm (3.54) for the mounting brackets</li> </ul> </li> </ul>	518 to 923 mm (20.39 to 36.34 in)	<ul style="list-style-type: none"> <li>• A minimum of 1000 mm (39.37 in) in depth (recommended)</li> <li>• A minimum of 130 mm (5.12 in) between the front rack post and the front door.</li> <li>• A minimum of 750 mm (29.53 in) between the front rack post and the rear door.</li> </ul>
	Mounting brackets at the power module side			

Switch model	Installation method	Chassis dimensions	Distance between the front and rear rack posts	Rack requirements
		brackets		
S9850-32H	Mounting brackets and long slide rails (provided)	<ul style="list-style-type: none"> <li>• <b>Height</b>—43.6 mm (1.72 in)/1 RU</li> <li>• <b>Width</b>—440 mm (17.32 in)</li> <li>• <b>Depth</b>—486 mm (19.13 in) <ul style="list-style-type: none"> <li>○ 460 mm (18.11 in) for the chassis</li> <li>○ 26 mm (1.02 in) for the power module/fan tray handles</li> </ul> </li> </ul>	621 to 853 mm (24.45 to 33.58 in)	<ul style="list-style-type: none"> <li>• A minimum of 1000 mm (39.37 in) in depth (recommended)</li> <li>• A minimum of 130 mm (5.12 in) between the front rack post and the front door.</li> <li>• A minimum of 550 mm (21.65 in) between the front rack post and the rear door.</li> </ul>
	Mounting brackets and short slide rails (provided)		401 to 633 mm (15.79 to 24.92 in)	

## Installation accessories

**Table2-3 Installation accessories**

Switch model	Mounting brackets (provided)	Cable management brackets	Rack mounting rail kit
S6850-56H F	1U high, one pair. See <a href="#">Figure2-11</a> .	N/A	1U high, including one pair of long slide rails and one pair of chassis rails (provided). See <a href="#">Figure2-14</a> .
			1U high, including one pair of super-short slide rails and one pair of chassis rails (optional). See <a href="#">Figure2-16</a> .
S6850-2C	1U high, one pair. See <a href="#">Figure2-11</a> .	N/A	1U high, including one pair of short slide rails and one pair of chassis rails (provided). See <a href="#">Figure2-15</a> .
S9850-4C	2U high, one pair. See <a href="#">Figure2-12</a> .	One pair (provided). See <a href="#">Figure2-12</a> .	2U high, including one pair of slide rails and one pair of chassis rails (provided). See <a href="#">Figure2-17</a> .
S9850-32H	1U high, one pair. See <a href="#">Figure2-13</a> .	N/A	1U high, including one pair of long slide rails and one pair of chassis rails (provided). See <a href="#">Figure2-14</a> .
			1U high, including one pair of short slide rails and one pair of chassis rails (optional). See <a href="#">Figure2-15</a> .



**Figure2-14 1U long slide rail and chassis rail**

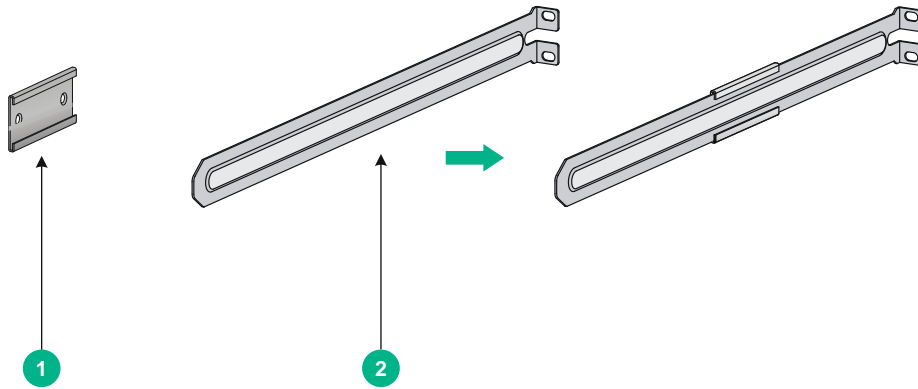

(1) Chassis rail

(2) Long slide rail

**Figure2-15 1U short slide rail and chassis rail**

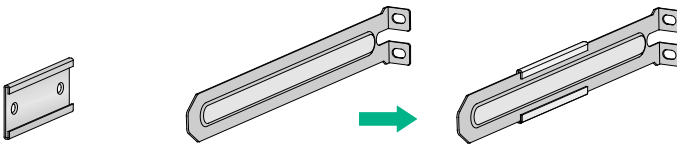

**Figure2-16 1U super-short slide rail and chassis rail**

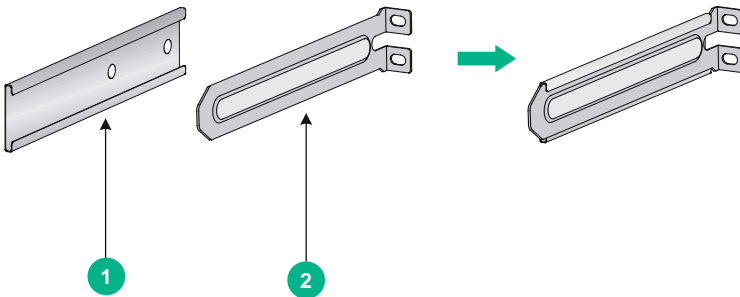

(1) Chassis rail

(2) Super-short slide rail

**Figure2-17 2U slide rail and chassis rail**

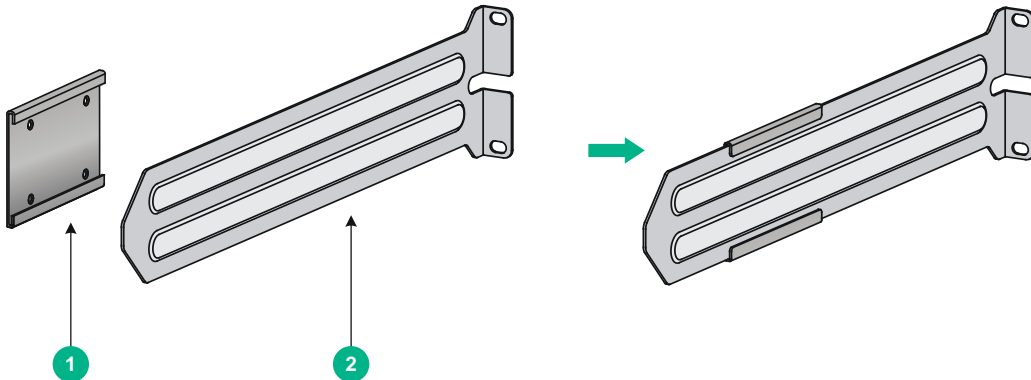

(1) Chassis rail

(2) Slide rail

# Mounting brackets, chassis rails, and grounding cable installation positions

The switch has one mounting position near the network ports and one mounting position near the power modules for mounting brackets.

The S6850-56HF switch provides two grounding points: primary grounding point (with a grounding sign) and auxiliary grounding point, as shown in [Figure2-18](#). The S6850-2C switch provides two grounding points: primary grounding point (with a grounding sign) and auxiliary grounding point, as shown in [Figure2-19](#). The S9850-4C switch provides three grounding points: primary grounding point (with a grounding sign), auxiliary grounding point 1, and auxiliary grounding point 2, as shown in [Figure2-20](#). The S9850-32H switch provides two grounding points: primary grounding point (with a grounding sign) and auxiliary grounding point, as shown in [Figure2-21](#).

Select installation positions for the mounting brackets, chassis rails, and grounding cable as required.

**Figure2-18 Mounting brackets and grounding cable installation positions on the S6850-56HF switch**

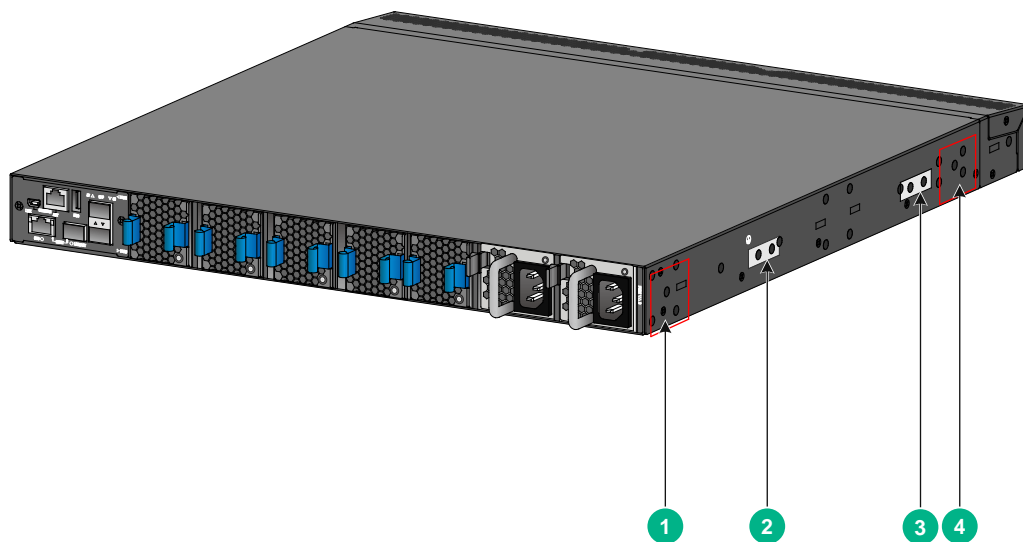

- 
- (1) Power module-side installation position for the mounting bracket
  - (2) Primary grounding point
  - (3) Auxiliary grounding point
  - (4) Port-side installation position for the mounting bracket
-

**Figure2-19 Mounting brackets and grounding cable installation positions on the S6850-2C switch**

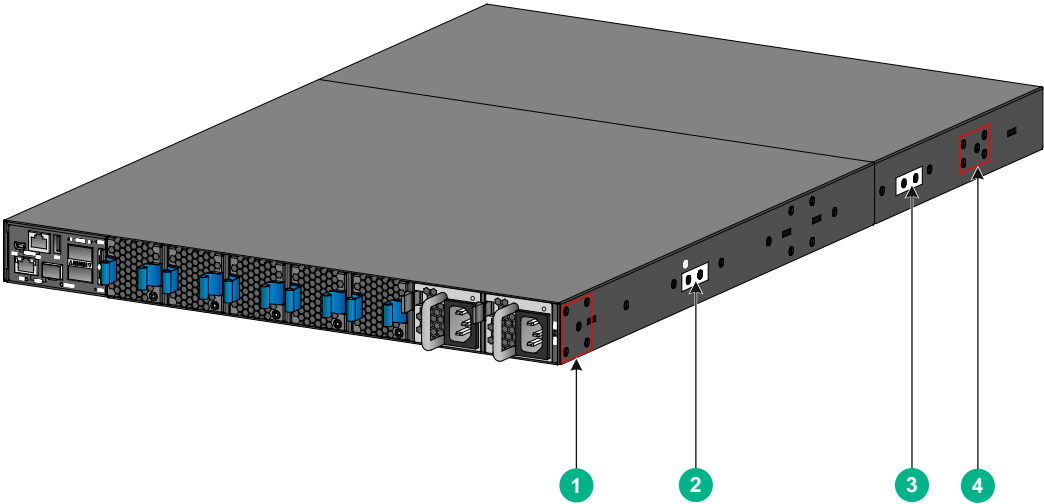

- 
- (1) Power module-side installation position for the mounting bracket
  - (2) Primary grounding point
  - (3) Auxiliary grounding point
  - (4) Port-side installation position for the mounting bracket
- 

**Figure2-20 Mounting brackets and grounding cable installation positions on the S9850-4C switch**

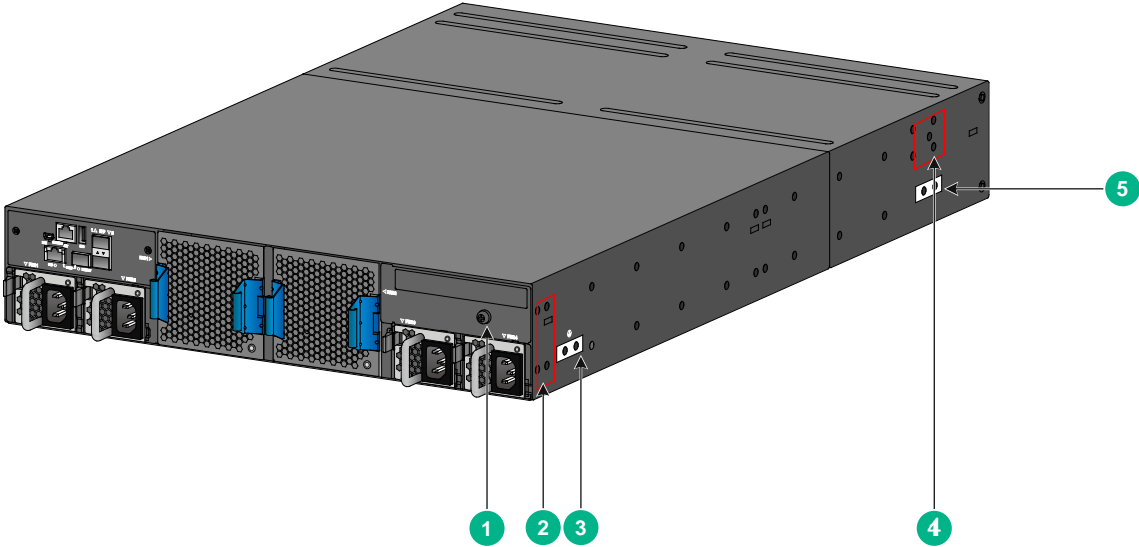

- 
- (1) Auxiliary grounding point 2
  - (2) Power module-side installation position for the mounting bracket
  - (3) Primary grounding point
  - (4) Port-side installation position for the mounting bracket
  - (5) Auxiliary grounding point 1
-



**Figure2-21 Mounting brackets and grounding cable installation positions on the S9850-32H switch**

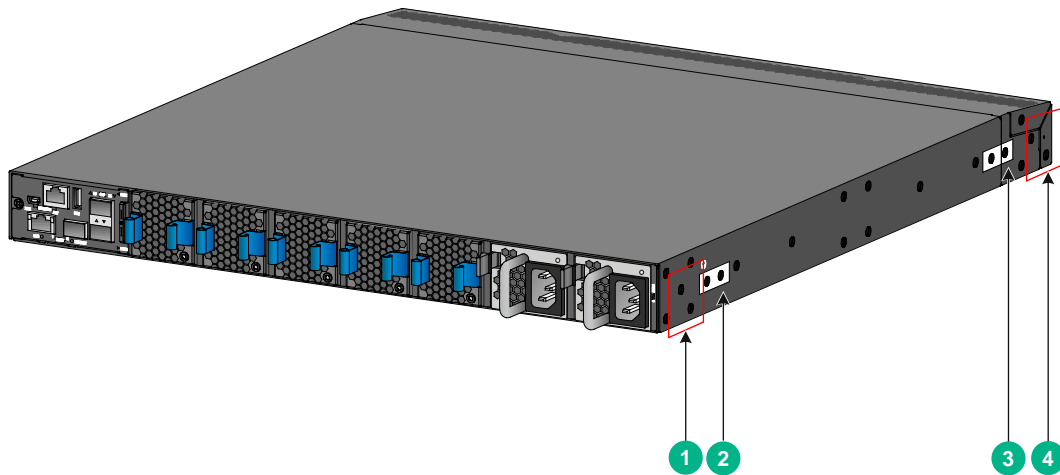

(1) Power module-side installation position for the mounting bracket	
(2) Primary grounding point	(3) Auxiliary grounding point
(4) Port-side installation position for the mounting bracket	

## Attaching the mounting brackets and chassis rails to the chassis

- Place the wide flange of the mounting bracket against the chassis side panel. Align the mounting bracket installation holes with the appropriate screw holes in the chassis. Use the provided M4 screws to attach the mounting bracket to the chassis (recommended torque: 12 kgf-cm).
  - To install the mounting brackets at the port-side mounting position, see [Figure2-22](#), [Figure2-23](#), [Figure2-24](#), [Figure2-28](#), [Figure2-30](#), and [Figure2-32](#).  
Use four installation holes to secure the mounting brackets to the S6850-56HF, S6850-2C, and S9850-4C switches. Use three installation holes to secure the mounting brackets to the S9850-32H switch.
  - To install the mounting brackets at the power module-side mounting position, see [Figure2-25](#), [Figure2-26](#), [Figure2-27](#), [Figure2-29](#), [Figure2-31](#), and [Figure2-33](#).  
Use four installation holes to secure the mounting brackets to the switch.
- Determine the installation position of the chassis rails based on the position of mounting brackets and the distance between the front and rear rack posts.

**Table2-4 Chassis rail installation position**

Switch model	Mounting bracket position	Distance between the front and rear rack posts	Chassis rail installation position
S6850-56HF (long slide rails)	Port-side mounting position, as shown in <a href="#">Figure2-22</a>	692 to 788 mm (27.24 to 31.02 in)	Position a
		692 to 853 mm (27.24 to 33.58 in)	Position b
	Power module-side mounting position, as shown in <a href="#">Figure2-25</a>	692 to 788 mm (27.24 to 31.02 in)	Position c
		692 to 853 mm (27.24 to 33.58 in)	Position d

Switch model	Mounting bracket position	Distance between the front and rear rack posts	Chassis rail installation position
S6850-56HF (super-short slide rails, chassis rails not reaching out of the chassis)	Port-side mounting position, as shown in <a href="#">Figure2-23</a>	401 to 500 mm (15.79 to 19.69 in)	Position a
		457 to 565 mm (17.99 to 22.24 in)	Position b
	Power module-side mounting position, as shown in <a href="#">Figure2-26</a>	401 to 500 mm (15.79 to 19.69 in)	Position c
		457 to 565 mm (17.99 to 22.24 in)	Position d
S6850-56HF (super-short slide rails, chassis rails reaching out of the chassis)	Port-side mounting position, as shown in <a href="#">Figure2-24</a>	499 to 627 mm (19.65 to 24.69 in)	Position a
		564 to 692 mm (22.20 to 27.24 in)	Position b
	Power module-side mounting position, as shown in <a href="#">Figure2-27</a>	499 to 627 mm (19.65 to 24.69 in)	Position c
		564 to 692 mm (22.20 to 27.24 in)	Position d
S6850-2C	Port-side mounting position, as shown in <a href="#">Figure2-28</a>	519 to 638 mm (20.43 to 25.12 in)	Position a
		524 to 703 mm (20.63 to 27.68 in)	Position b
		589 to 768 mm (23.19 to 30.24 in)	Position c
		654 to 833 mm (25.75 to 32.80 in)	Position d
	Power module-side mounting position, as shown in <a href="#">Figure2-29</a>	589 to 768 mm (23.19 to 30.24 in)	Position e
		524 to 703 mm (20.63 to 27.68 in)	Position f
520 to 638 mm (20.47 to 25.12 in)	Position g		
S9850-4C	Port-side mounting position, as shown in <a href="#">Figure2-30</a>	675 to 923 mm (26.57 to 36.34 in)	Position a
		611 to 858 mm (24.06 to 33.78 in)	Position b
		546 to 793 mm (21.50 to 31.22 in)	Position c
		518 to 728 mm (20.39 to 28.66 in)	Position d
	Power module-side mounting position, as shown in <a href="#">Figure2-31</a>	518 to 728 mm (20.39 to 28.66 in)	Position e
		546 to 793 mm (21.50 to 31.22 in)	Position f
		611 to 858 mm (24.06 to 33.78 in)	Position g
S9850-32H (long slide rails)	Port-side mounting position, as shown in <a href="#">Figure2-32</a>	621 to 788 mm (24.45 to 31.02 in)	Position a
		621 to 853 mm (24.45 to 33.58 in)	Position b
	Power module-side mounting position, as shown in <a href="#">Figure2-33</a>	621 to 853 mm (24.45 to 33.58 in)	Position c
		621 to 788 mm (24.45 to 31.02 in)	Position d
S9850-32H (short slide rails)	Port-side mounting position, as shown in <a href="#">Figure2-32</a>	401 to 588 mm (15.79 to 23.15 in)	Position a
		454 to 633 mm (17.87 to 24.92 in)	Position b
	Power module-side mounting position, as shown in <a href="#">Figure2-33</a>	454 to 633 mm (17.87 to 24.92 in)	Position c
		401 to 568 mm (15.79 to 22.36 in)	Position d

- Place the chassis rail against the chassis side panel. Align the chassis rail installation holes with the screw holes. Use the provided M4 screws to attach the chassis rail to the chassis (recommended torque: 12 kgf-cm). See [Figure2-22](#) to [Figure2-31](#).

You can use super-short slide rails and long chassis rails to rack-mount the S6850-56HF switch. Based on the rack depth, install the long chassis rails with the chassis rails not reaching out of

the chassis, as shown in [Figure2-23](#) and [Figure2-26](#) or with the chassis rails reaching out of the chassis, as shown in [Figure2-24](#) and [Figure2-27](#).

**Figure2-22 Attaching the mounting brackets and chassis rails to the S6850-56HF switch (port-side mounting position for the mounting brackets, long slide rails)**

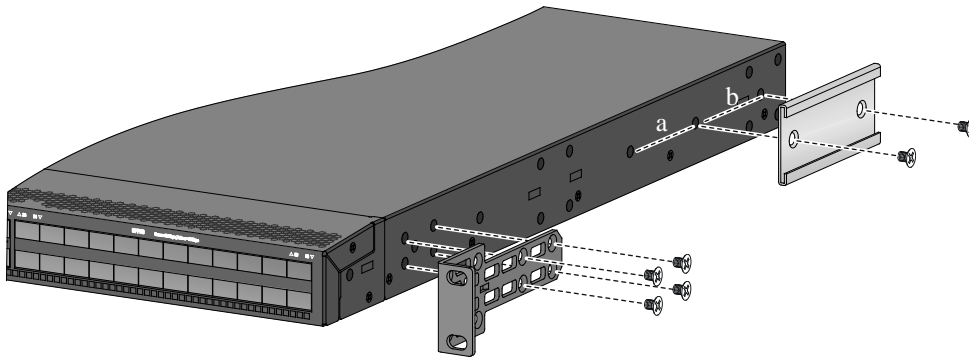

**Figure2-23 Attaching the mounting brackets and chassis rails to the S6850-56HF switch (port-side mounting position for the mounting brackets, super-short slide rails, chassis rails not reaching out of the chassis)**

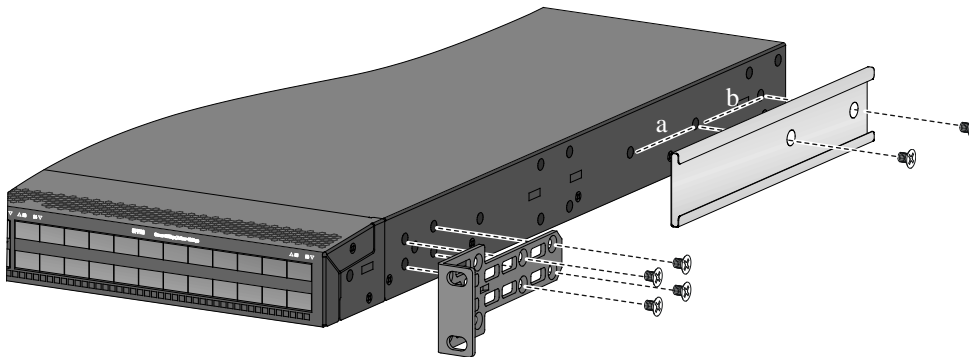

**Figure2-24 Attaching the mounting brackets and chassis rails to the S6850-56HF switch (port-side mounting position for the mounting brackets, super-short slide rails, chassis rails reaching out of the chassis)**

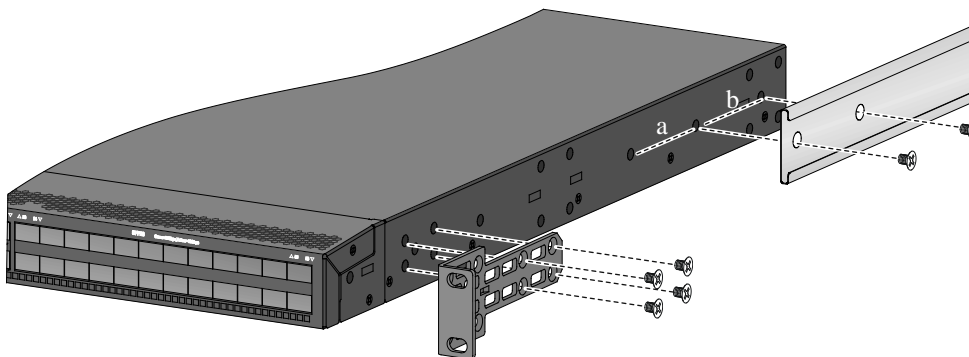

**Figure2-25 Attaching the mounting brackets and chassis rails to the S6850-56HF switch (power module-side mounting position for the mounting brackets, long slide rails)**

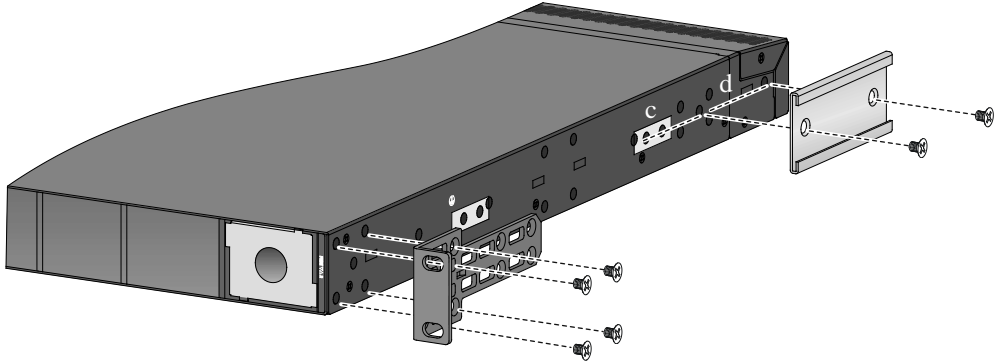

**Figure2-26 Attaching the mounting brackets and chassis rails to the S6850-56HF switch (power module-side mounting position for the mounting brackets, super-short slide rails, chassis rails not reaching out of the chassis)**

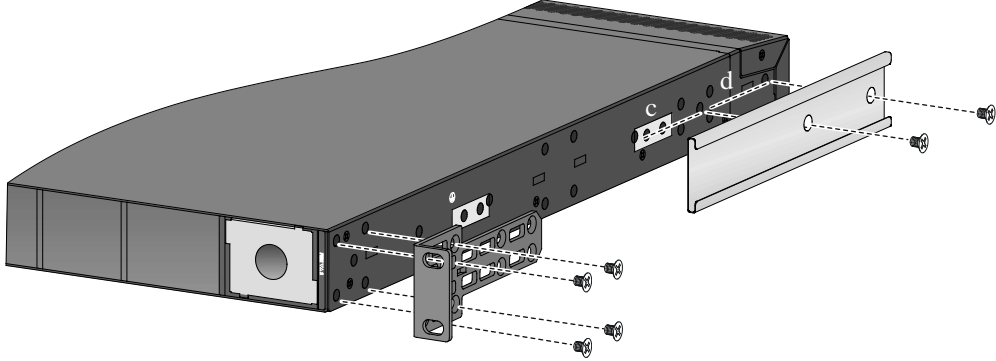

**Figure2-27 Attaching the mounting brackets and chassis rails to the S6850-56HF switch (power module-side mounting position for the mounting brackets, super-short slide rails, chassis rails reaching out of the chassis)**

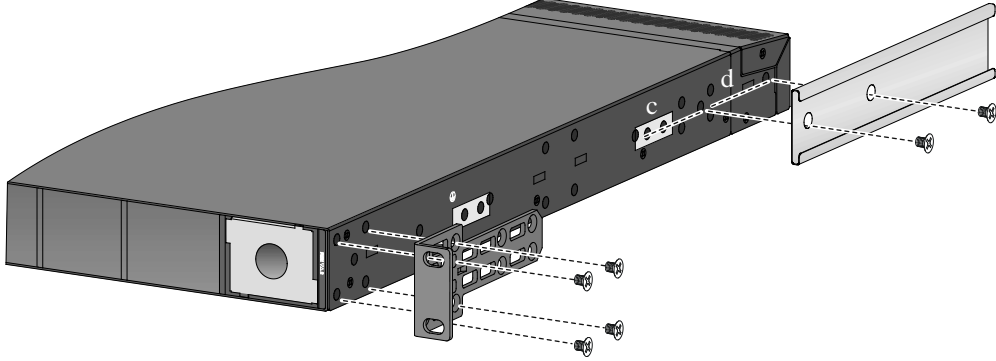

**Figure2-28 Attaching the mounting brackets and chassis rails to the S6850-2C switch (port-side mounting position for the mounting brackets)**

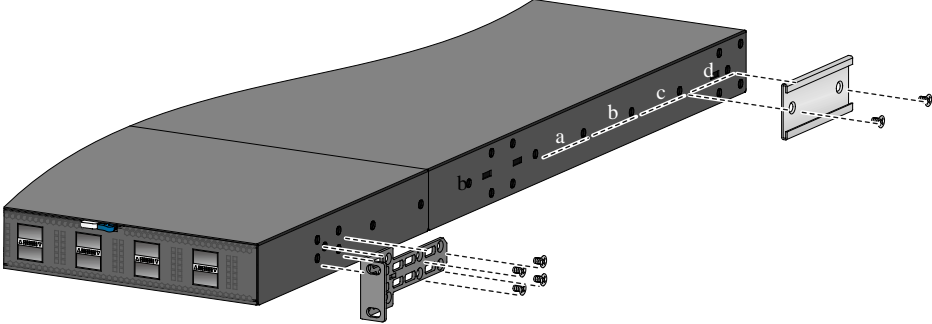

**Figure2-29 Attaching the mounting brackets and chassis rails to the S6850-2C switch (power module-side mounting position for the mounting brackets)**

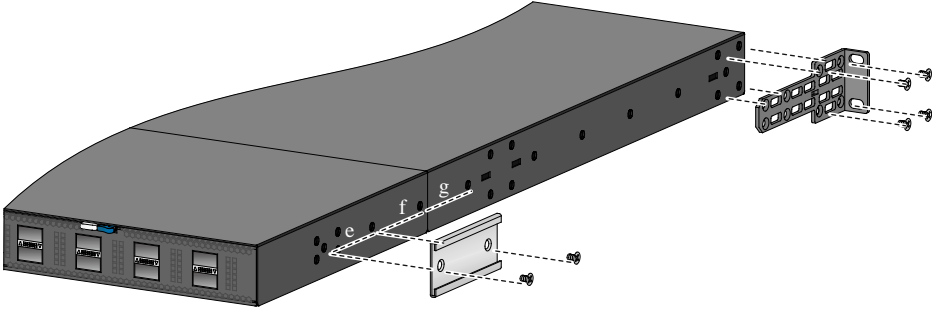

**Figure2-30 Attaching the mounting brackets and chassis rails to the S9850-4C switch (port-side mounting position for the mounting brackets)**

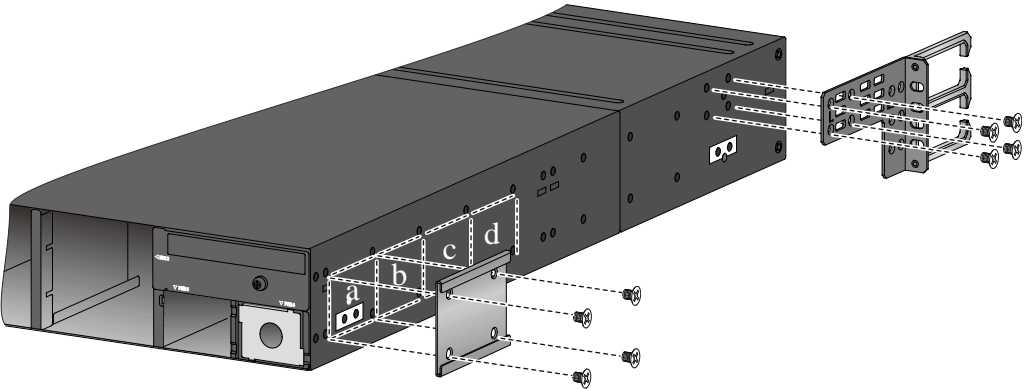

**Figure2-31 Attaching the mounting brackets and chassis rails to the S9850-4C switch (power module-side mounting position for the mounting brackets)**

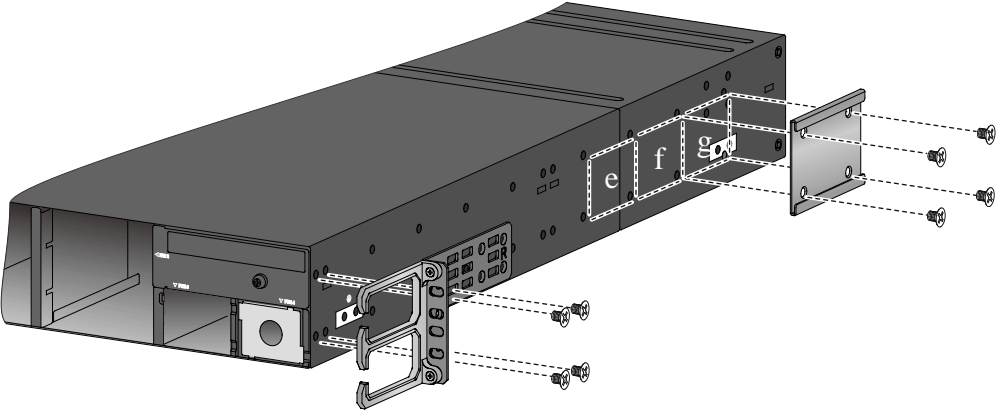

**Figure2-32 Attaching the mounting brackets and chassis rails to the S9850-32H switch (port-side mounting position for the mounting brackets)**

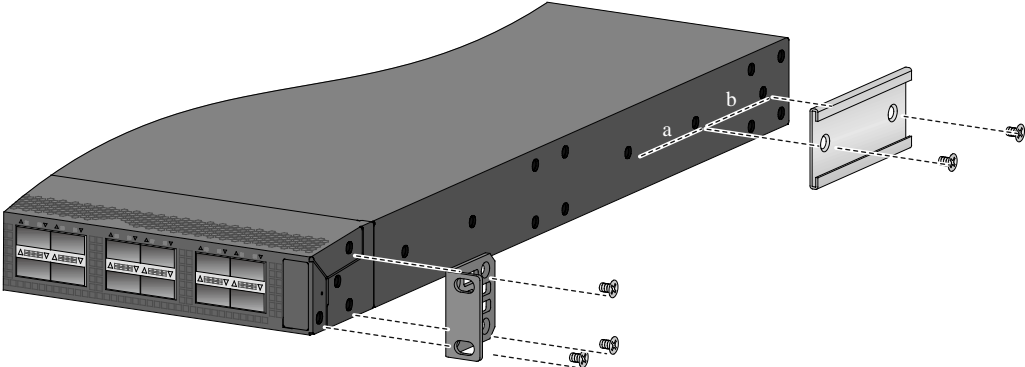

**Figure2-33 Attaching the mounting brackets and chassis rails to the S9850-32H switch (power module-side mounting position for the mounting brackets)**

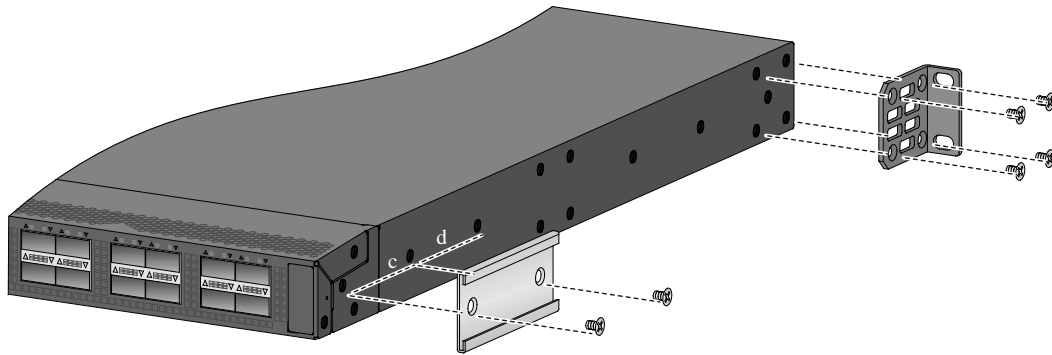

---

**NOTE:**

Secure the mounting brackets and chassis rails to both sides of the chassis in the same way.

---

## Connecting the grounding cable to the chassis

---

**!** **IMPORTANT:**

- If the grounding cable length or terminal type cannot meet your requirement, make an applicable grounding cable or contact H3C Support.
  - If you use a grounding point on the side panel to ground the switch, connect the grounding cable to the grounding point before installing the switch in the rack.
- 

For an S6850-56HF, S6850-2C, or S9850-32H switch, the primary grounding point and auxiliary grounding point are on the left side panel. Both grounding points support a grounding cable that has a single-hole lug or dual-hole lug. Use M5 grounding screws to attach the grounding cable to the switch. Choose the grounding point according to the mounting bracket installation positions.

- If you install the mounting bracket at the port side, connect the grounding cable to the grounding point at the port side.
- If you install the mounting bracket at the power module side, connect the grounding cable to the grounding point at the power module side.

For an S9850-4C switch, the primary grounding point and auxiliary grounding point 1 are on the left side panel, and auxiliary grounding point 2 is on the rear panel. If you use a grounding cable that has a dual-hole lug, connect it to the primary grounding point or auxiliary grounding point 1. If you use a grounding cable that has a single-hole lug, connect it to auxiliary grounding point 2. Use M5 grounding screws to attach the grounding cable to the switch. Choose the grounding point according to the mounting bracket installation positions.

To connect the grounding cable:

1. Choose a grounding point as required.
2. Unpack the grounding cable and grounding screws.

3. Use the grounding screws to attach the grounding lug of the grounding cable to the grounding holes at the grounding point (recommended torque: 20 kgf-cm). Use a screwdriver to tighten the screws. See [Figure2-34](#), [Figure2-35](#), and [Figure2-36](#).

**Figure2-34 Attaching a grounding cable that has a single-hole lug to the grounding point (S6850-56HF)**

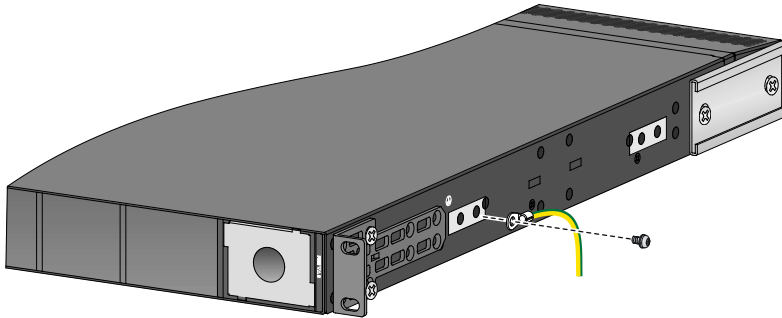

**Figure2-35 Attaching a grounding cable that has a dual-hole lug to the grounding point (S6850-56HF)**

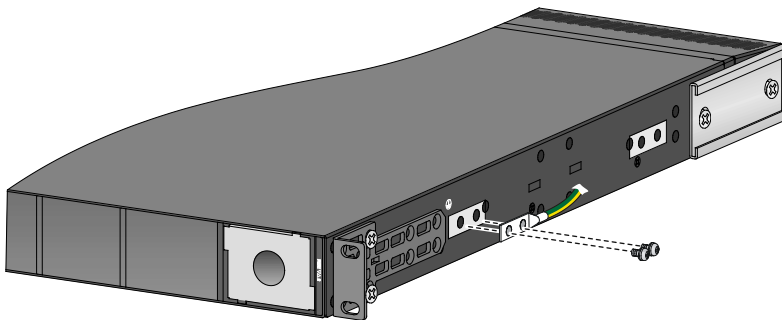

**Figure2-36 Attaching a grounding cable to auxiliary grounding point 2 on the S9850-4C switch**

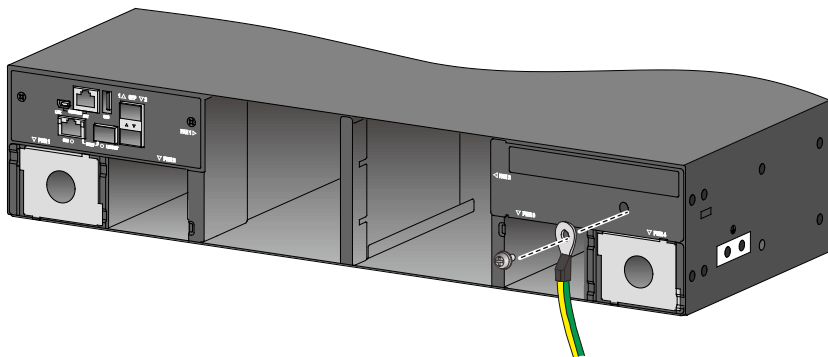

## Attaching the slide rails to the rack

The procedure is the same for attaching 1U and 2U slide rails to the rack. This section uses the 1U slide rails as an example.



To attach the slide rails to the rack:

1. Identify the slide rail installation position in the rack.
2. Install cage nuts (user-supplied) in the mounting holes in the rack posts.
3. Align the screw holes in one slide rail with the cage nuts in a rear rack post. Use user-supplied M6 screws to attach the slide rail to the post (recommended torque: 30 kgf-cm). See [Figure2-37](#).
4. Repeat the preceding steps to attach the other slide rail to the other rear rack post.  
Keep the two slide rails at the same height so the slide rails can attach into the chassis rails.

**Figure2-37 Installing the 1U slide rails**

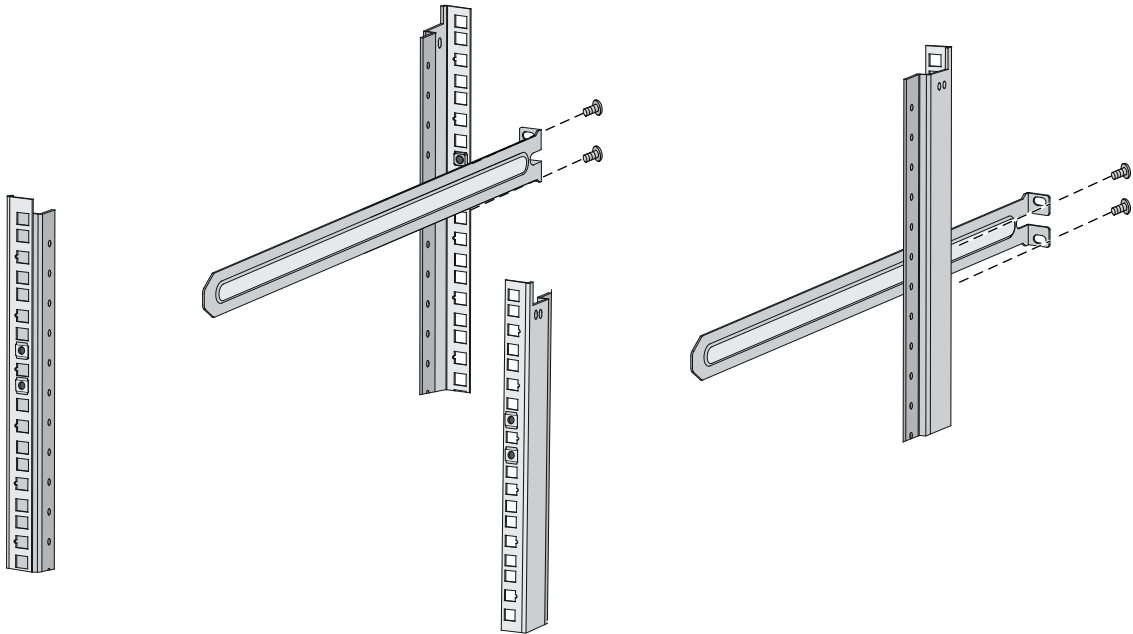

## Mounting the switch in the rack

This task requires two people.

To mount the switch in the rack:

1. Wear an ESD wrist strap and make sure it makes good skin contact and is reliably grounded.
2. Verify that the mounting brackets and chassis rails have been securely attached to the switch chassis.
3. Verify that the slide rails have been correctly attached to the rear rack posts.
4. Attach cage nuts (user-supplied) to the front rack posts and make sure they are at the same level as the slide rails.

---

**⚠ CAUTION:**

To rack-mount the S9850-4C switch by using 2U high mounting brackets and slide rails, use four M6 screws and four cage nuts to attach each mounting bracket to the rack, as shown in [Figure2-42](#) and [Figure2-43](#).

---

5. One person performs the following operations:
  - a. Supporting the bottom of the switch, aligns the chassis rails with the slide rails on the rack posts.

- b. Pushes the switch slowly to slide the chassis rails along the slide rails until the mounting brackets are flush with the rack posts.

---

**! IMPORTANT:**

- If you use long slide rails to rack-mount the S6850-56HF, make sure the front ends of the long slide rails reach out of the chassis rails for a maximum of 20 mm (0.79 in). If you use super-short slide rails to rack-mount the S6850-56HF, make sure the front ends of the super-short slide rails reach inside the chassis rails for a minimum of 90 mm (3.54 in) after installation.
  - To rack-mount the S6850-2C and S9850-32H, make sure the front ends of the slide rails reach out of the chassis rails for a minimum of 20 mm (0.79 in) after installation.
  - To rack-mount the S9850-4C, make sure the front ends of the slide rails reach out of the chassis rails for a minimum of 30 mm (1.18 in) after installation.
- 

6. Another person uses user-supplied M6 screws to attach the mounting brackets to the rack (recommended torque: 30 kgf-cm).

**Figure2-38 Mounting the S6850-56HF switch in the rack (port-side mounting position for the mounting brackets)**

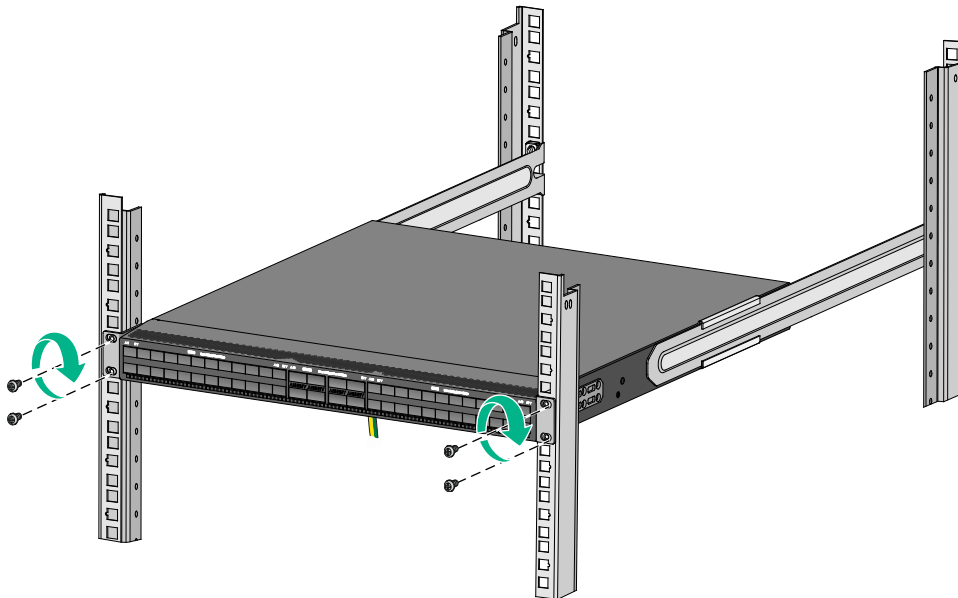

**Figure2-39 Mounting the S6850-56HF switch in the rack (power module-side mounting position for the mounting brackets)**

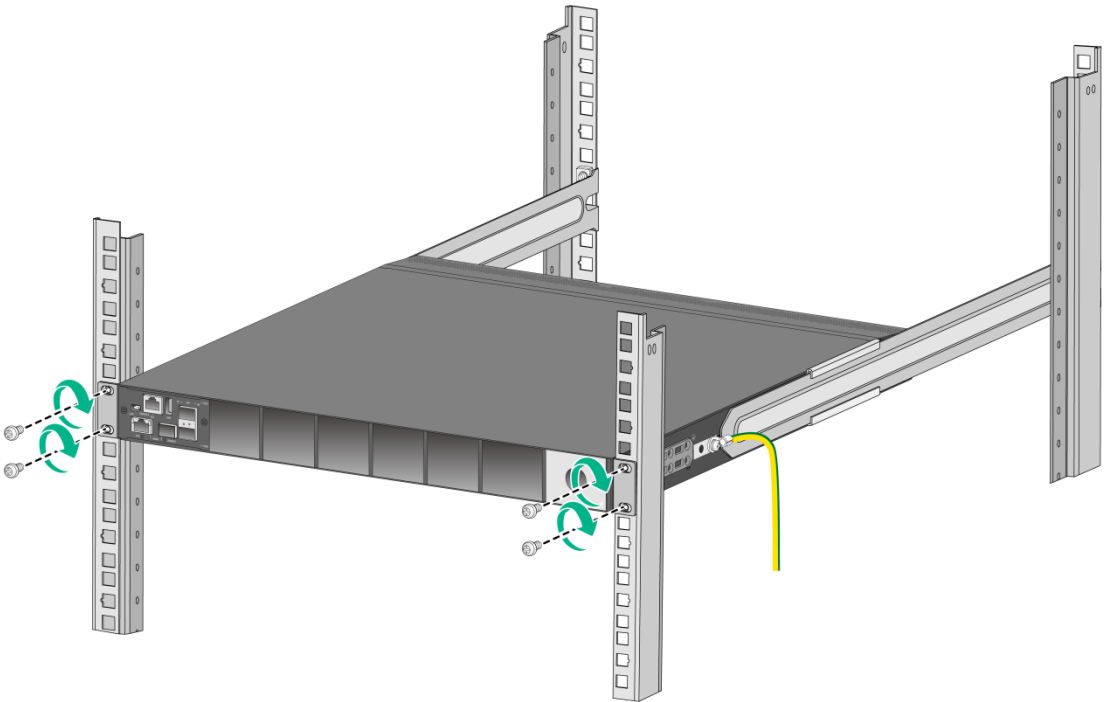

**Figure2-40 Mounting the S6850-2C switch in the rack (port-side mounting position for the mounting brackets)**

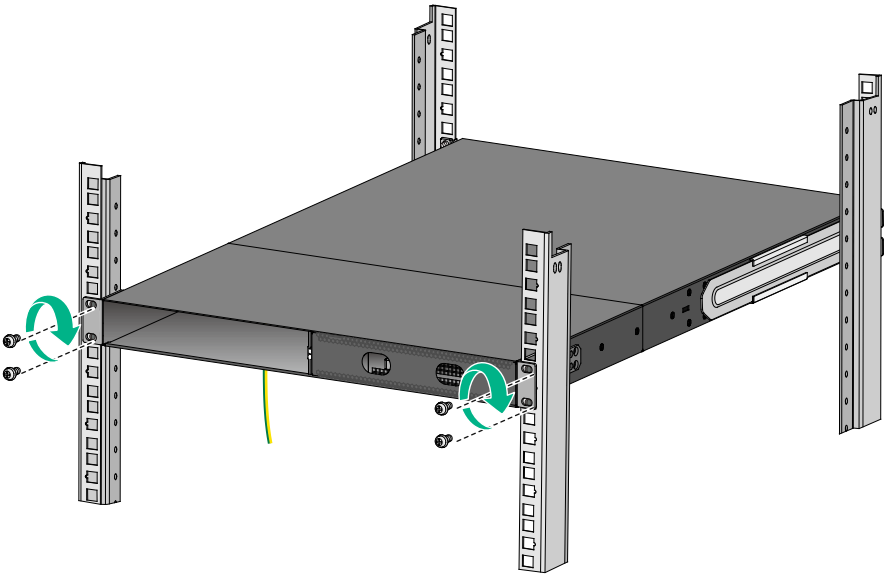

**Figure2-41 Mounting the S6850-2C switch in the rack (power module-side mounting position for the mounting brackets)**

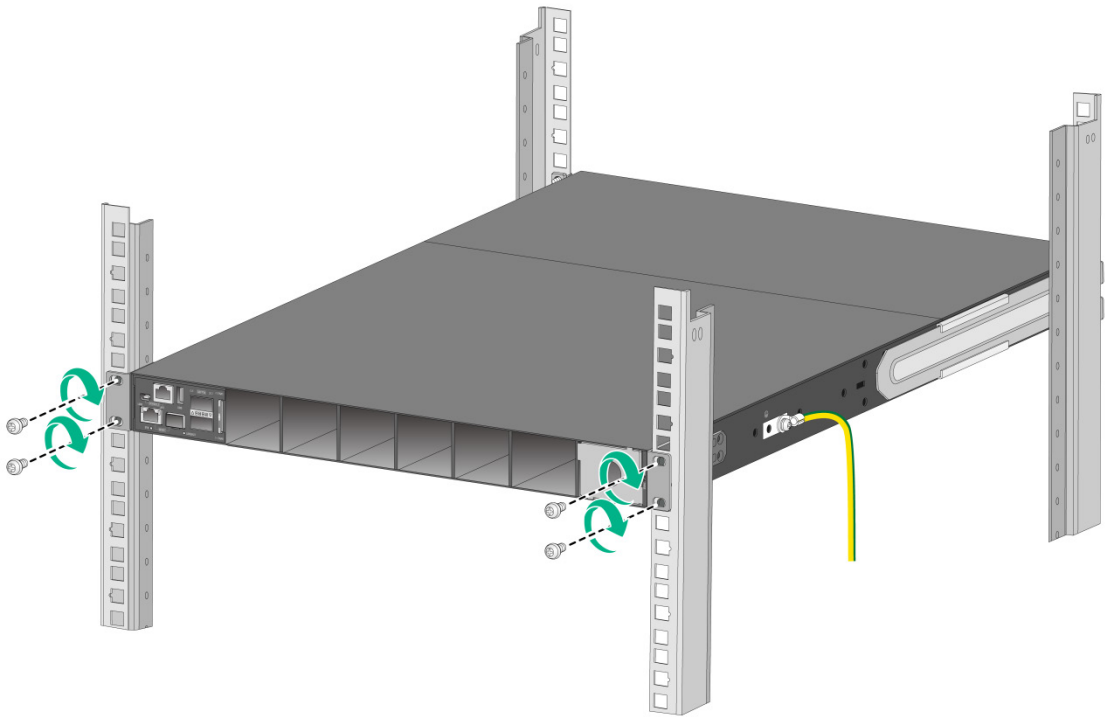

**Figure2-42 Mounting the S9850-4C switch in the rack (port-side mounting position for the mounting brackets)**

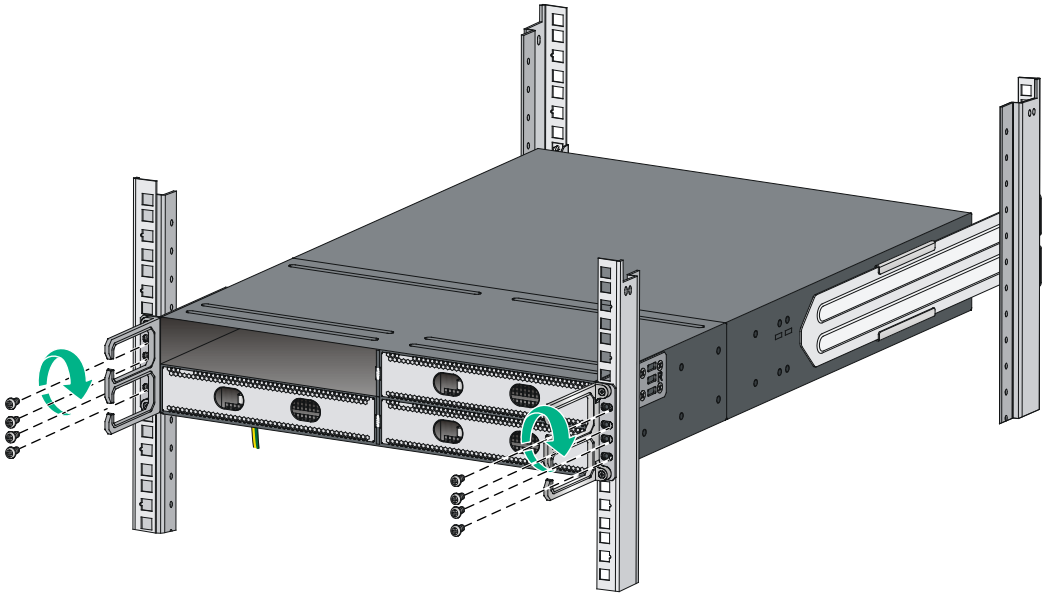

**Figure2-43 Mounting the S9850-4C switch in the rack (power module-side mounting position for the mounting brackets)**

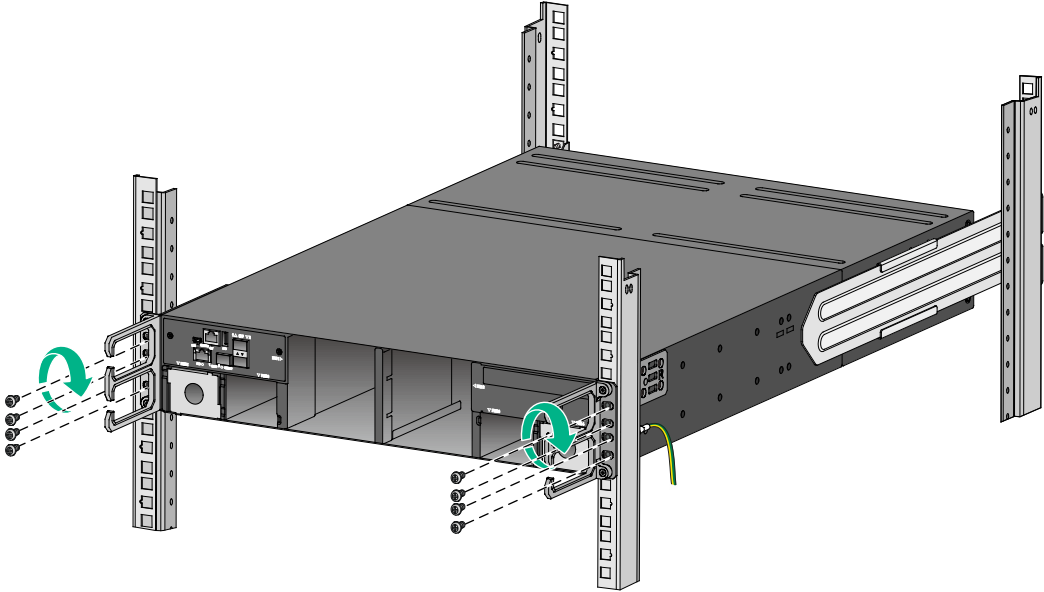

**Figure2-44 Mounting the S9850-32H switch in the rack (port-side mounting position for the mounting brackets)**

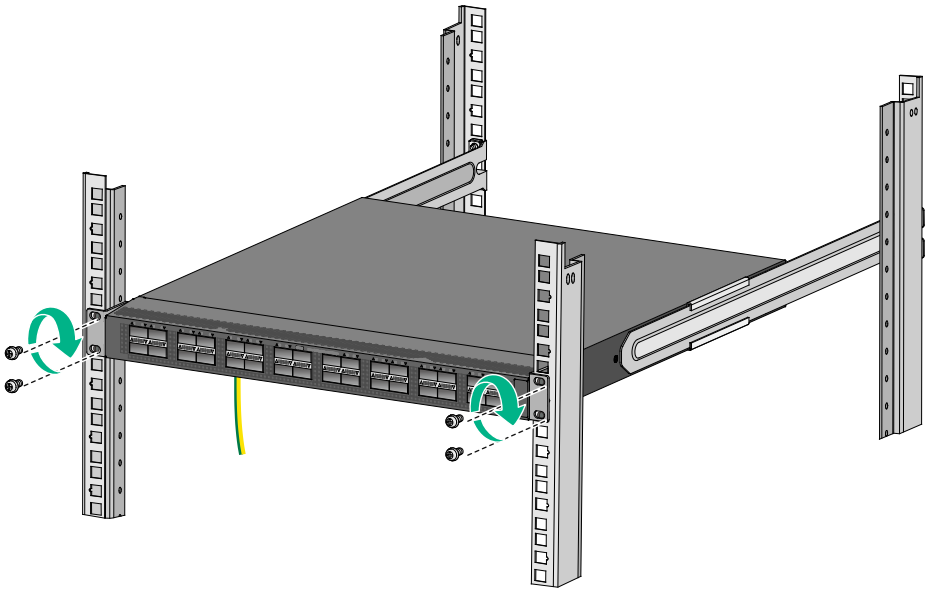

**Figure2-45 Mounting the S9850-32H switch in the rack (power module-side mounting position for the mounting brackets)**

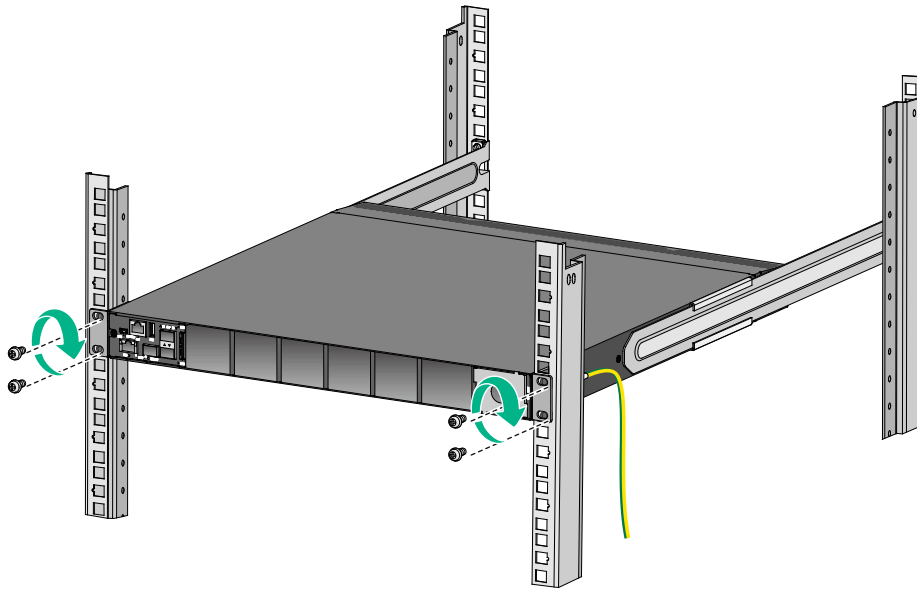

## Grounding the switch

### ⚠ CAUTION:

- Correctly connecting the grounding cable is crucial to lightning protection and EMI protection.
- Connect the grounding cable to the grounding system in the equipment room. Do not connect it to a fire main or lightning rod.

The power input end of the switch has a noise filter, whose central ground is directly connected to the chassis to form the chassis ground (commonly known as PGND). You must securely connect this chassis ground to the earth so the faradism and leakage electricity can be safely released to the earth to minimize EMI susceptibility of the switch.

You can ground a switch by using a grounding strip at the installation site.

### NOTE:

- The grounding terminals in this section are for illustration only.
- As a best practice to guarantee the grounding effect, use the grounding cable provided with the switch to connect to the grounding strip in the equipment room.

To connect the grounding cable:

1. Attach the two-hole grounding lug of the grounding cable to a grounding point on the chassis. For more information, see "[Connecting the grounding cable to the chassis.](#)"
2. Remove the hex nut of a grounding post on the grounding strip.
3. Attach the ring terminal of the grounding cable to the grounding post on the grounding strip, and secure the ring terminal to the grounding post with the hex nut.

Figure2-46 Connecting the grounding cable to a grounding strip

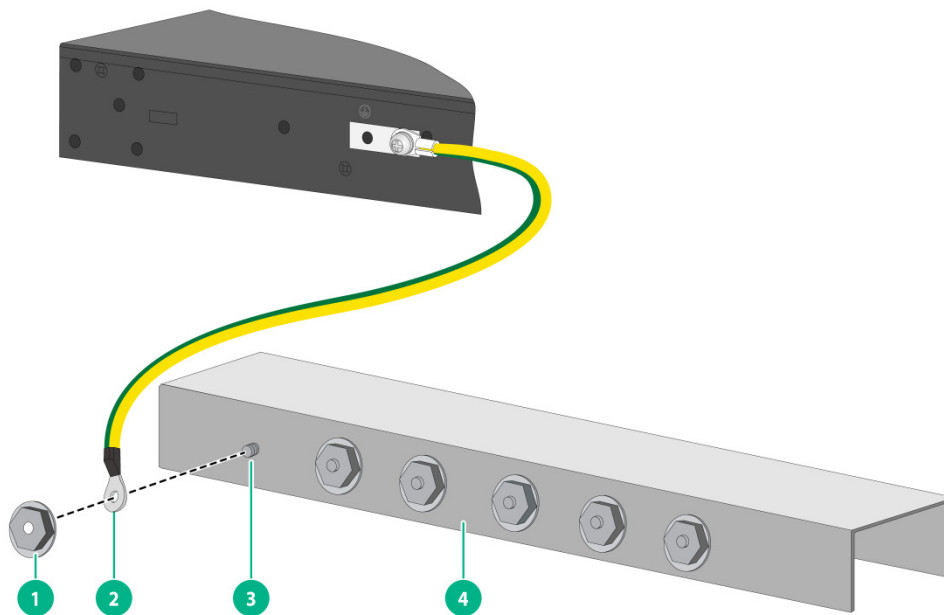

(1) Hex nut

(2) Ring terminal

(3) Grounding post

(4) Grounding strip

## Installing/removing fan trays

### ⚠ CAUTION:

The switch has multiple fan tray slots. To ensure good ventilation of the switch, follow these guidelines to install and remove fan trays:

- The switch is provided with the fan tray slots empty. Before powering on the switch, make sure all fan tray slots have fan trays installed and the fan trays are the same model.
- Make sure all slots have a module or filler panel installed when the switch is operating.
- If multiple fan trays fail on an operating S6850-56HF, S6850-2C, or S9850-32H switch, do not remove the fan trays at the same time. Replace the fan trays one after another and finish replacing a fan tray within 3 minutes.
- If a fan tray fails on an operating S9850-4C switch, replace the fan tray immediately and keep the failed fan tray in position before replacement. If two fan trays fail, finish replacing the fan trays within 1 minute.

The installation and removal procedures are the same for fan trays of different models. The following installation and removal procedures use the LSWM1FANSA fan tray as an example.

## Installing a fan tray

### ⚠ CAUTION:

To prevent damage to the fan tray or the connectors on the backplane, insert the fan tray gently. If you encounter a hard resistance while inserting the fan tray, pull out the fan tray and insert it again.

---

**!** **IMPORTANT:**

Before powering on the switch, make sure the fan tray airflow direction and the preferred airflow direction of the switch are the same. If they are not the same, the system generates traps and logs. You can use the **fan prefer-direction** command to configure the preferred airflow direction for the switch. By default, the preferred airflow direction of the switch is from the port side to the power module side. For more information about the **fan prefer-direction** command, see [H3C S6805 & S6825 & S6850 & S9850 Switch Series Fundamentals Command Reference](#).

---

Select fan trays for the switch as needed. For the available fan trays and their specifications, see [H3C S6850 & S9850 Switch Series Hardware Information and Specifications](#).

To install a fan tray:

1. Wear an ESD wrist strap and make sure it makes good skin contact and is reliably grounded.
2. Unpack the fan tray and verify that the fan tray model is correct.
3. Orient the fan tray with the "TOP" mark on top. Grasp the handle of the fan tray with one hand and support the fan tray bottom with the other, and slide the fan tray along the guide rails into the slot until the fan tray is fully seated in the slot and has a firm contact with the backplane. See [Figure2-47](#).

**Figure2-47 Installing an LSWM1FANSA fan tray in the S6850-56HF switch**

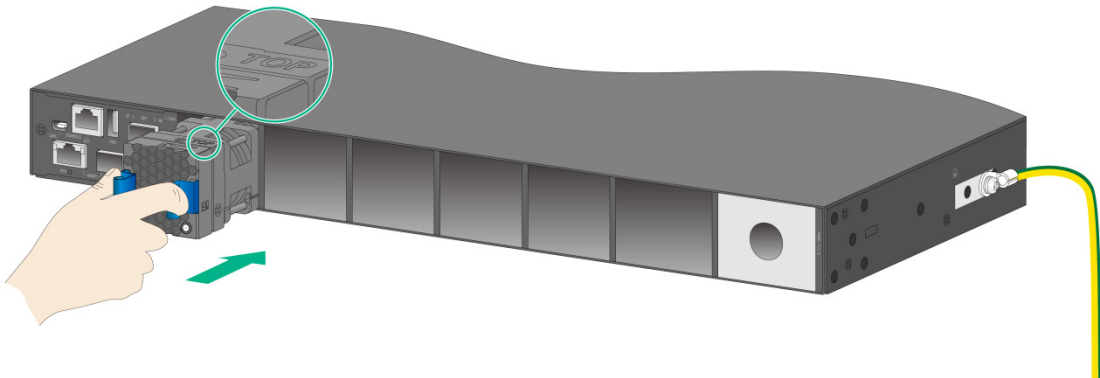

## Removing a fan tray

---

**!** **WARNING!**

- Ensure electricity safety and never touch the rotating fans when you hot-swap a fan tray.
  - To prevent a fan from causing loud noise, do not touch the fan blades and rotation axis, even if the fan is not rotating.
- 

To remove a fan tray:

1. Wear an ESD wrist strap and make sure it makes good skin contact and is reliably grounded.
2. Grasp the handle of the fan tray with one hand and pull the fan tray part way out of the slot. Support the fan tray bottom with the other and pull the fan tray completely out of the slot.
3. Put the removed fan tray in an antistatic bag.



Figure2-48 Removing an LSWM1FANSA fan tray

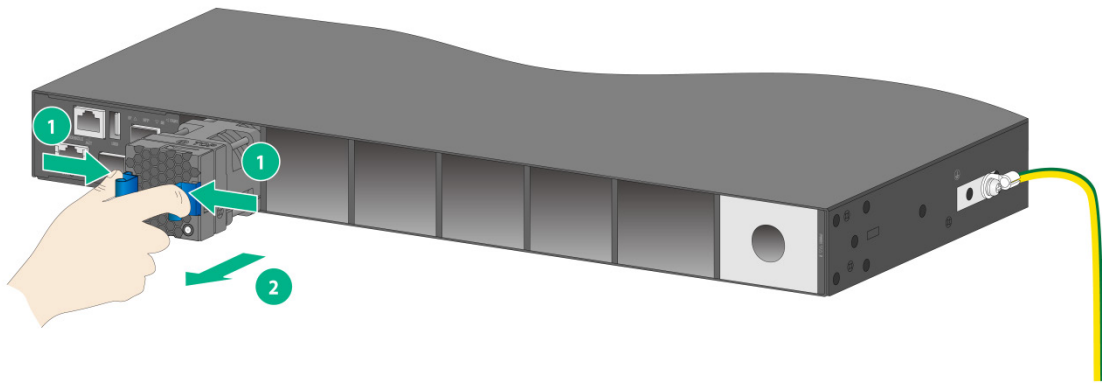

## Installing/removing power modules

### ⚠ WARNING!

- To avoid bodily injury and device damage, strictly follow the procedures in [Figure2-49](#) and [Figure2-50](#) to install and remove a power module.
- Provide a separate circuit breaker for each power module.

The S6850-56HF, S6850-2C, and S9850-32H switches each have two power module slots. The S9850-4C switch has four power module slots. The S6850-56HF, S6850-2C, and S9850-32H switches each come with one power module slot empty and one installed with a filler panel. The S9850-4C switch comes with two power module slots empty and two installed with filler panels. You can install power modules for the switch as required.

For information about the available power modules, see *H3C S6850 & S9850 Switch Series Hardware Information and Specifications*.

### Figure2-49 Installation procedure

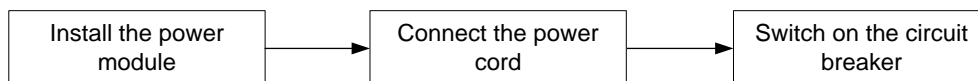

### Figure2-50 Removal procedure

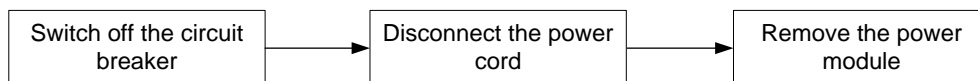

## Installing a power module

### ⚠ CAUTION:

- Follow the forward inertia of the power module when inserting it into the chassis, and make sure the power module has firm contact with the connectors on the backplane.
- To prevent damage to the connectors inside the switch chassis, insert the power module gently. If you encounter a hard resistance while inserting the power module, pull out the power module and insert it again.

The LSVM1AC650 and LSVM1DC650 installation procedure is the same on the S6850 and S9850 series switches. The figures in this section use the S6850-56HF switch as an example.

To install a power module:

1. Wear an ESD wrist strap and make sure it makes good skin contact and is reliably grounded.
2. Remove the filler panel, if any, from the target power module slot, as shown in [Figure2-51](#).

**Figure2-51 Removing a filler panel**

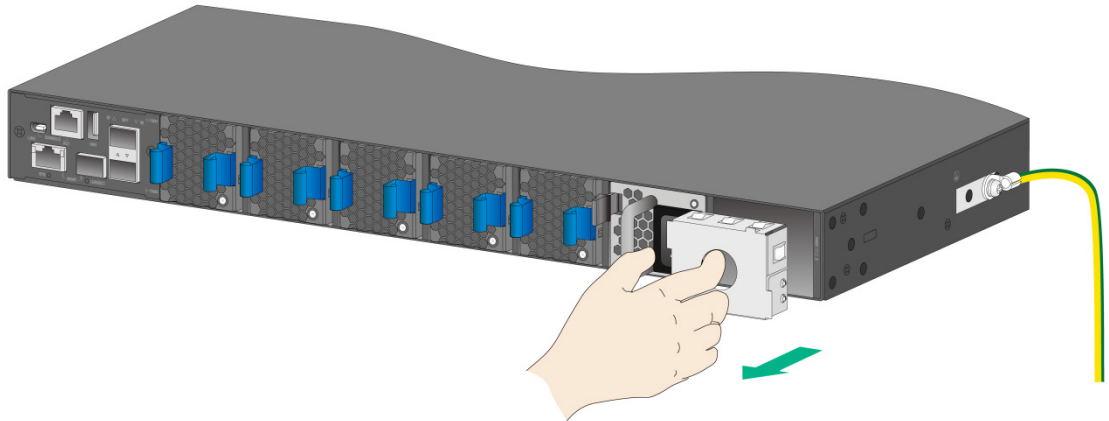

3. Unpack the power module and verify that the power module model is correct.
4. Correctly orient the power module with the words on the power module upward. Grasp the handle of the power module with one hand and support its bottom with the other, and slide the power module slowly along the guide rails into the slot.

The slot is foolproof. If you cannot insert the power module into the slot, re-orient the power module rather than use excessive force to push it in.

**Figure2-52 Installing a power module (LSVM1AC650)**

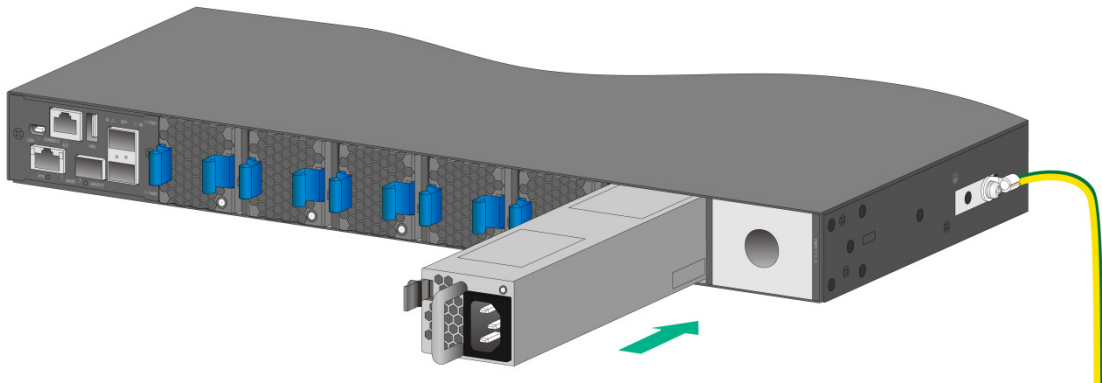

# Removing a power module

## ⚠ CAUTION:

- When an S6850-56HF, S6850-2C, or S9850-32H switch has two power modules in 1+1 redundancy mode, removing one power module does not affect the operation of the switch. When the switch has only one power module installed, removing the power module powers off the switch.
- When an S9850-4C switch has power modules in 2+1 or 2+2 redundancy mode, removing one or two power modules does not affect the operation of the switch. When the switch has only two power modules installed, removing power modules powers off the switch or causes power insufficiency.

The LSVM1AC650 and LSVM1DC650 removal procedure is the same on the S6850 and S9850 series switches. The figures in this section use the S6850-56HF switch as an example.

To remove a power module:

1. Wear an ESD wrist strap and make sure it makes good skin contact and is reliably grounded.
2. Remove the power cord from the power module. To remove a DC power cord, squeeze the tabs on the power cord connector with your thumb and forefinger, and then pull the connector out, as shown in [Figure2-53](#).
3. Hold the handle on the power module with one hand, pivot the latch on the power module to the right with your thumb, and pull the power module part way out of the slot, as shown in [Figure2-54](#).
4. Supporting the power module bottom with one hand, slowly pull the power module out with the other hand.
5. Put the removed power module in an antistatic bag for future use.
6. If you are not to install a new power module, install a filler panel in the slot to ensure good ventilation in the switch, as shown in [Figure2-55](#).

**Figure2-53 Removing the DC power cord**

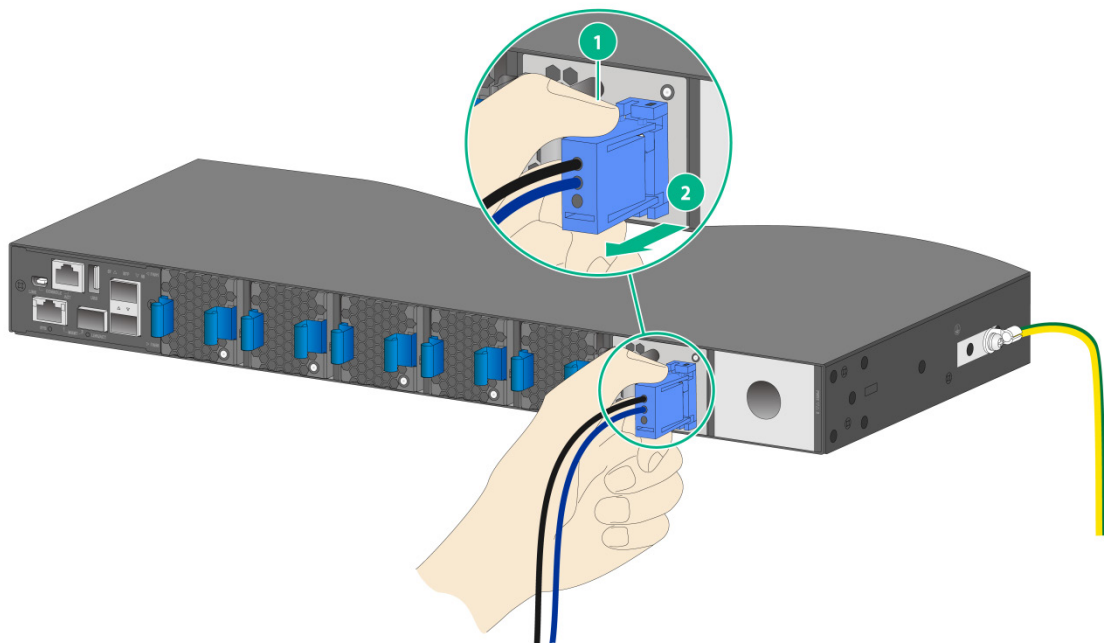

- 
- (1) Press the tabs on the power cord connector with your thumb and forefinger
  - (2) Pull the power cord connector out
-

Figure2-54 Removing the power module

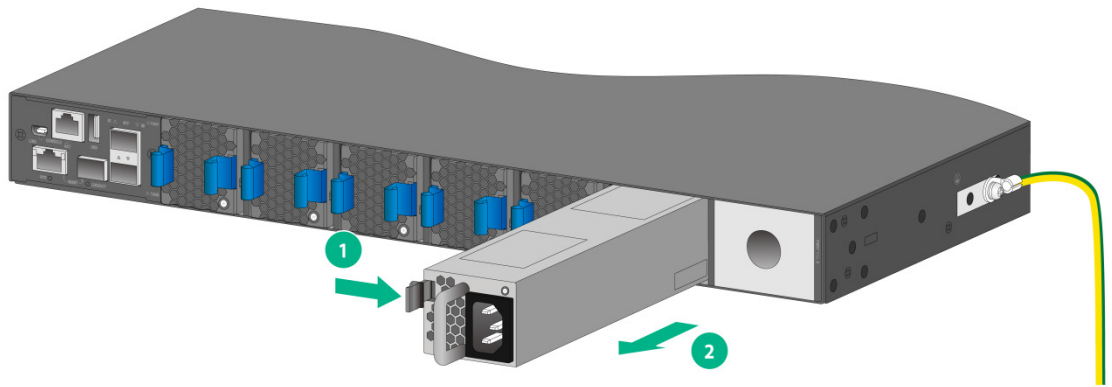

(1) Pivot the latch to the right with your thumb

(2) Pull the power module out

Figure2-55 Installing a filler panel

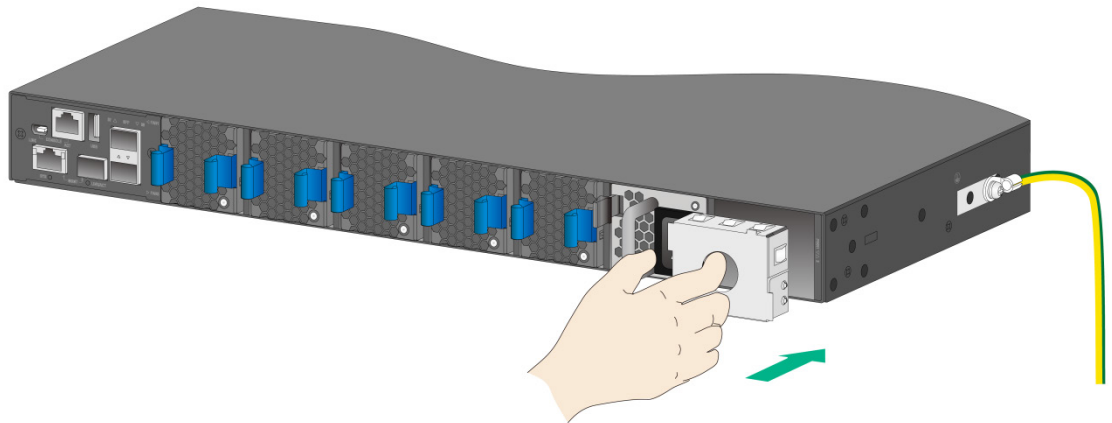

## Connecting the power cords

### **⚠ WARNING!**

Provide a circuit breaker for each power input. When you connect a power cord, make sure the circuit breaker is switched off.

## Connecting an AC power cord

1. Insert the female connector of the AC power cord supplied with the power module into the power receptacle on the power module.
2. Use a cable tie to secure the power cord to the handle of the power module, as shown in [Figure2-56](#).
3. Connect the other end of the power cord to an AC power outlet.

**Figure2-56 Connecting an AC power cord to the LSVM1AC650 power module**

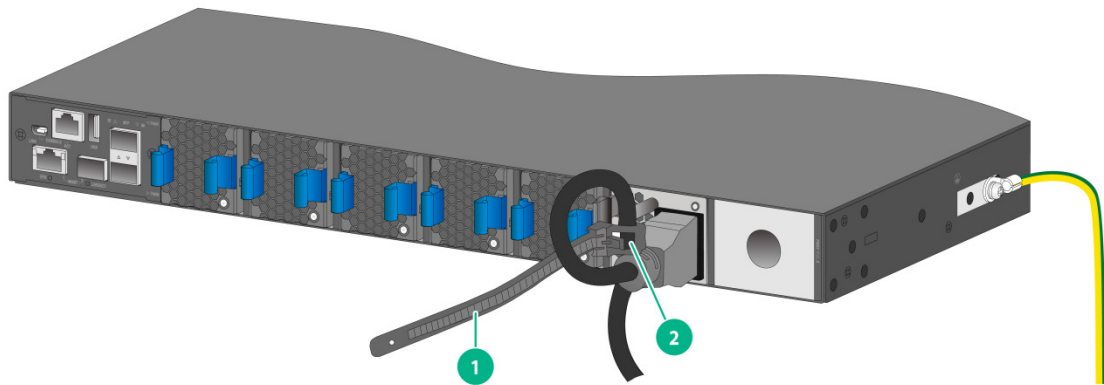

---

(1) Cable tie

(2) Tighten the cable tie to secure the power cord to the handle of the power module

---

## Connecting a DC power cord

1. Align the power cord plug with the power receptacle on the power module, and insert the plug into the receptacle (see [Figure2-57](#)).  
The plug and receptacle are foolproof. If you cannot insert the plug into the receptacle, re-orient the plug rather than use excessive force to push it in.
2. Use a cable tie to secure the power cord to the handle of the power module, as shown in [Figure2-56](#).
3. Connect the other end of the power cord to the DC power source.

**Figure2-57 Connecting a DC power cord to the LSVM1DC650 power module**

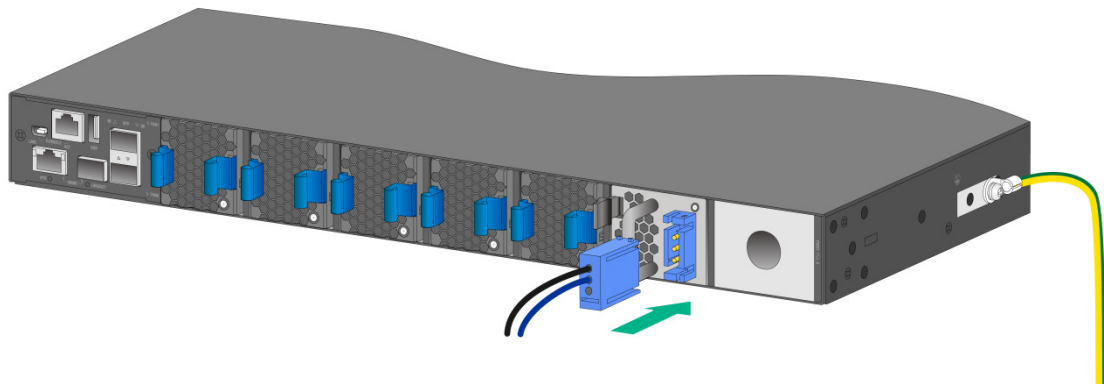

If the provided DC power cord cannot meet your connection requirements, use the following table to prepare a suitable copper cable as the DC power cord.

**Table2-5 Requirements for a suitable DC power cord**

Power module model	Power cord connector	Minimum cross sectional area of the conductor	Cross sectional area of the provided power cord	Maximum cross sectional area of the conductor
LSVM1DC650	Use the connector of the provided power cord	3.3 mm <sup>2</sup> or 12 AWG	3.3 mm <sup>2</sup> or 12 AWG	5.3 mm <sup>2</sup> or 10 AWG

## Installing/removing expansion modules

### ⚠ CAUTION:

When you install or remove an expansion module, follow these guidelines:

- Never touch the components on the expansion module surface with bare hands.
- Do not use excessive force.
- Do not install or remove an expansion module during the startup of the switch. Hot swapping an expansion module when the switch is operating correctly.

The S6850-2C switch provides two expansion slots. The S9850-4C switch provides four expansion slots. For the available expansion modules, see *H3C S6850 & S9850 Switch Series Hardware Information and Specifications*.

The installation and removal procedures are the same for expansion modules. This section installs and removes an LSWM18CQ interface module on the S9850-4C switch.

## Installing an expansion module

1. Wear an ESD wrist strap and make sure the wrist strap makes good skin contact and is reliably grounded.
2. (Optional.) If the target expansion slot has a filler panel installed, remove the filler panel, as shown in [Figure2-58](#).
  - a. Use your thumb and forefinger to hold the filler panel through the two holes.
  - b. Push right the metal tab in the left hole and pull out the filler panel along the guide rails.

**Figure2-58 Removing the filler panel from the expansion slot**

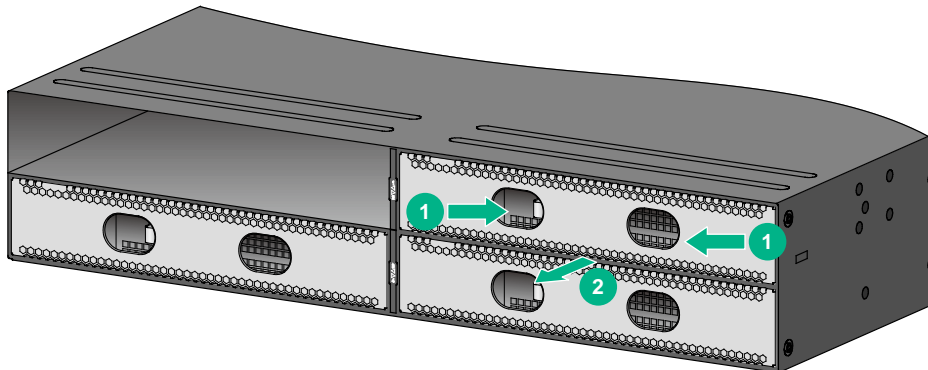

Keep the removed filler panel secure for future use.

3. Unpack the expansion module.
4. Press the latch on the expansion module to release the ejector lever.

**Figure2-59 LSWM18CQ interface module**

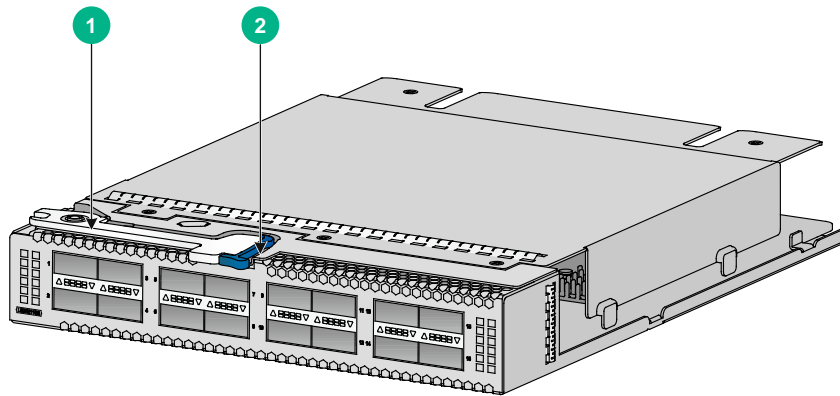

---

(1) Ejector lever

(2) Latch

---

5. Insert the expansion module slowly into the slot along the guide rails, as shown by callout 1 in [Figure2-60](#).
6. Rotate inward the ejector lever as shown by callout 2 in [Figure2-60](#) until the latch locks the ejector lever in place.

**Figure2-60 Installing the LSWM18CQ interface module**

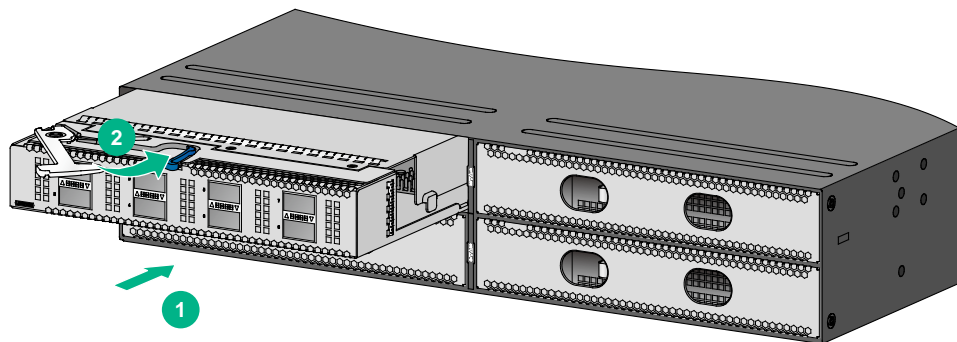

## Removing an expansion module

---

**△ CAUTION:**

- Before you remove an expansion module, remove the cable from it to avoid cable damage.
  - If you are not to install a new expansion module after removing the original one, install a filler panel in the slot to prevent dust and ensure good ventilation.
- 

To remove an expansion module:

1. Prepare an anti-static bag.
2. Wear an ESD wrist strap and make sure the wrist strap makes good skin contact and is reliably grounded.
3. Press the latch to release the ejector lever as shown by callout 1 in [Figure2-61](#).

4. Rotate outward the ejector lever as shown by callout 2 in [Figure2-61](#).
5. Pull out the expansion module slowly out of the expansion slot, as shown by callout 3 in [Figure2-61](#).
6. Place the removed expansion module in the anti-static bag.

**Figure2-61 Removing an LSWM18CQ interface module**

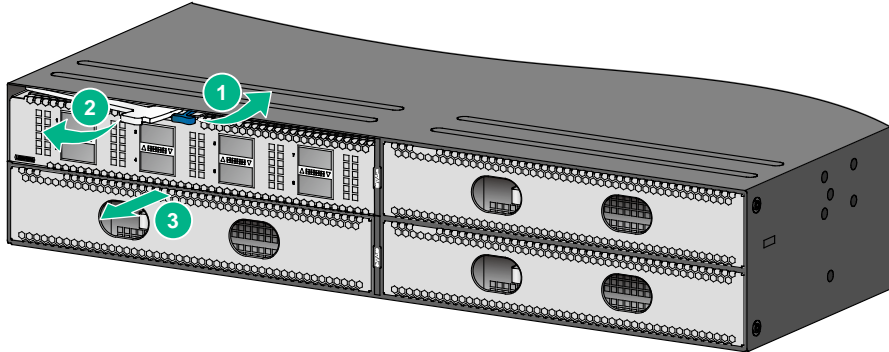

## Verifying the installation

After you complete the installation, verify that:

- There is enough space for heat dissipation around the switch, and the rack is stable.
- The grounding cable is securely connected.
- The correct power source is used.
- The power cords are correctly connected.
- All the interface cables are cabled indoors. The switch does not support outdoor cable routing.



# 3 Accessing the switch for the first time

## Setting up the configuration environment

You can access the switch through the serial console port or the mini USB console port. As a best practice, use the serial console port to access the switch. To access the switch through the mini USB console port, you need to prepare a mini USB console cable yourself.

The example uses a console cable to connect a console terminal (PC) to the serial console port on the switch.

**Figure3-1 Connecting the serial console port to a terminal**

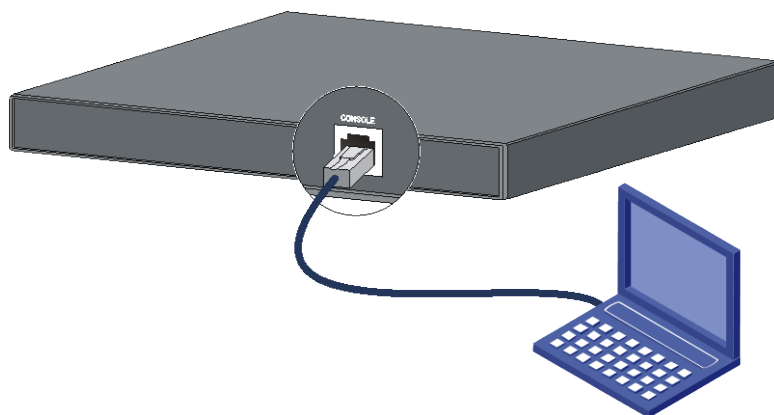

## Connecting the console cable

A serial console cable is an 8-core cable, with a crimped RJ-45 connector at one end for connecting to the serial console port of the switch, and a DB-9 female connector at the other end for connecting to the serial port on the console terminal.

**Figure3-2 Serial console cable**

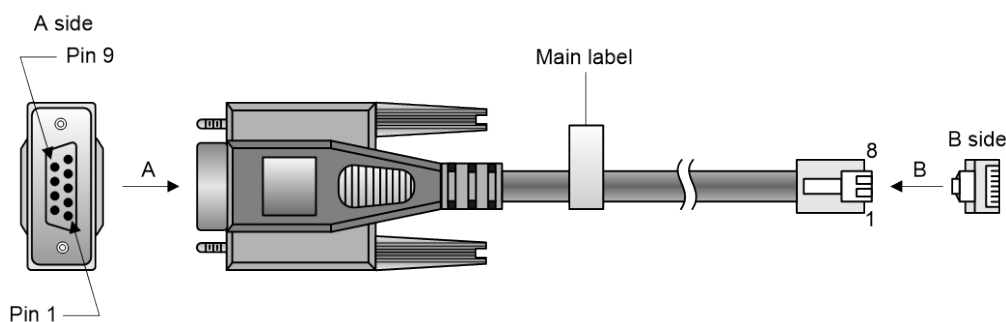

**Table3-1 Console port signaling and pinout**

RJ-45	Signal	DB-9	Signal
1	RTS	8	CTS
2	DTR	6	DSR

RJ-45	Signal	DB-9	Signal
3	TXD	2	RXD
4	SG	5	SG
5	SG	5	SG
6	RXD	3	TXD
7	DSR	4	DTR
8	CTS	7	RTS

To connect a terminal (for example, a PC) to the switch by using the serial console cable:

1. Plug the DB-9 female connector of the serial console cable to the serial port of the PC.
2. Connect the RJ-45 connector to the serial console port of the switch.

---

**NOTE:**

- Identify the mark on the console port and make sure you are connecting to the correct port.
  - The serial ports on PCs do not support hot swapping. To connect a PC to an operating switch, first connect the PC end. To disconnect a PC from an operating switch, first disconnect the switch end.
- 

## Connecting the mini USB console cable

A mini USB console cable has a USB mini-Type B connector at one end to connect to the mini USB console port of the switch, and a standard USB Type A connector at the other end to connect to the USB port on the configuration terminal.

To connect to the configuration terminal through the USB mini console cable:

1. Connect the standard USB Type A connector to the USB port of the configuration terminal.
2. Connect the USB mini Type B connector to the Mini USB console port of the switch.
3. Click the following link, or copy it to the address bar on the browser to log in to download page of the USB console driver, and download the driver.

[http://www.h3c.com/en/home/USB\\_Console/](http://www.h3c.com/en/home/USB_Console/)

4. Select a driver program according to the operating system you use:
  - **XR21V1410\_XR21B1411\_Windows\_Ver1840\_x86\_Installer.EXE**—32-bit operating system.
  - **XR21V1410\_XR21B1411\_Windows\_Ver1840\_x64\_Installer.EXE**—64-bit operating system.
5. Click **Next** on the installation wizard.

Figure3-3 Device Driver Installation Wizard

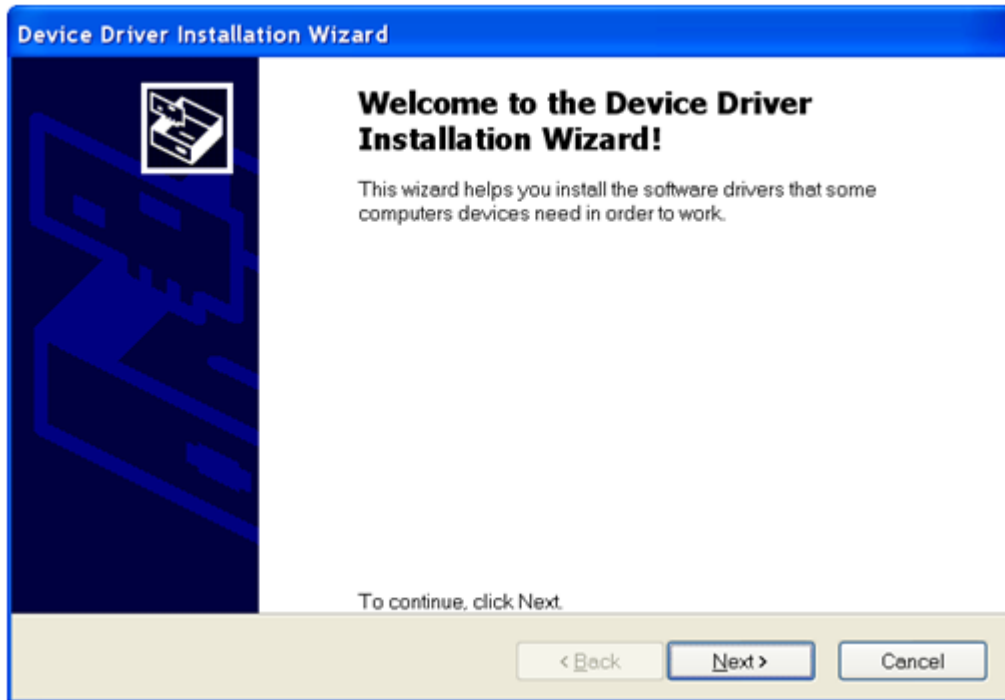

6. Click **Continue Anyway** if the following dialog box appears.

Figure3-4 Software Installation

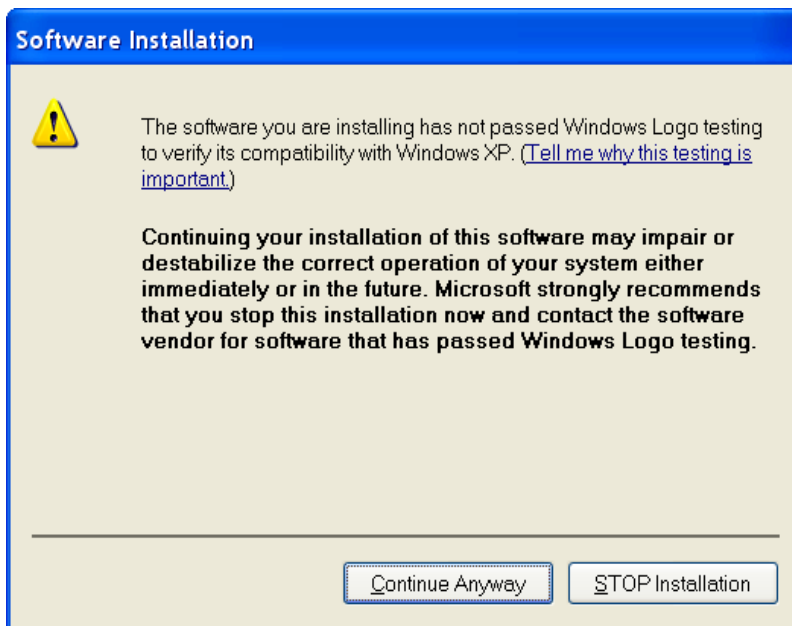

7. Click **Finish**.

Figure3-5 Completing the device driver installation wizard

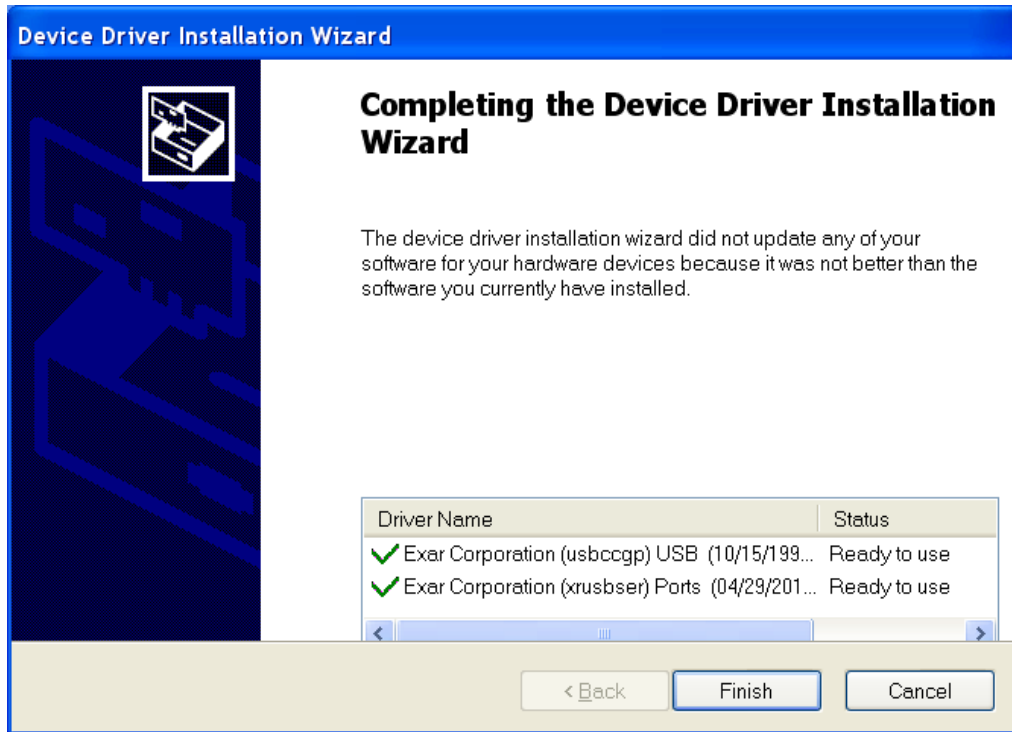

## Setting terminal parameters

To configure and manage the switch through the console port, you must run a terminal emulator program, TeraTermPro or PuTTY, on your configuration terminal. You can use the emulator program to connect a network device, a Telnet site, or an SSH site. For more information about the terminal emulator programs, see the user guides for these programs

The following are the required terminal settings:

- **Bits per second**—9600.
- **Data bits**—8.
- **Stop bits**—1.
- **Parity**—None.
- **Flow control**—None.

## Powering on the switch

1. Before powering on the switch, verify that the following conditions are met:
  - All the fan tray slots have a fan tray installed.
  - The power cords are connected correctly.
  - The input power voltage is as required by the switch.
  - The console cable is connected correctly.
  - The configuration terminal (a PC, for example) has started, and its serial port settings are consistent with the console port settings on the switch.

**2.** Power on the switch.

During the startup process, you can access BootWare menus to perform tasks such as software upgrade and file management. The BootWare interface and menu options vary by software version. For more information about BootWare menu options, see the software-matching release notes for the device.

**3.** After the startup completes, you can access the CLI to configure the switch.

For more information about the configuration commands and CLI, see *H3C S6805 & S6825 & S6850 & S9850 Switch Series Configuration Guides* and *H3C S6805 & S6825 & S6850 & S9850 Switch Series Command References*.

# 4 Setting up an IRF fabric

You can use H3C IRF technology to connect and virtualize multiple S6850/S9850 switches into a large virtual switch called an "IRF fabric" for flattened network topology, and high availability, scalability, and manageability.

## IRF fabric setup flowchart

Figure4-1 IRF fabric setup flowchart

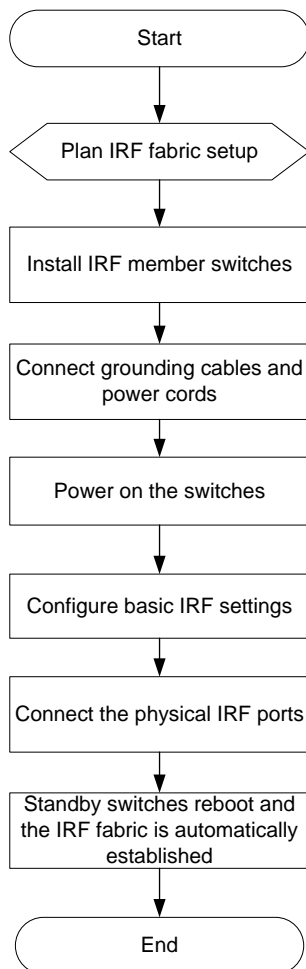

To set up an IRF fabric:

Step	Description
1. Plan IRF fabric setup.	<p>Plan the installation site and IRF fabric setup parameters:</p> <ul style="list-style-type: none"><li>• <a href="#">Planning IRF fabric size and the installation site</a></li><li>• <a href="#">Identifying the master switch and planning IRF member IDs</a></li><li>• <a href="#">Planning IRF topology and connections</a></li><li>• <a href="#">Identifying physical IRF ports on the member switches</a></li><li>• <a href="#">Planning the cabling scheme</a></li></ul>

Step	Description
2. Install IRF member switches.	See " <a href="#">Installing the switch in a 19-inch rack</a> ".
3. Connect ground wires and power cords.	See " <a href="#">Grounding the switch</a> " and " <a href="#">Connecting the power cords</a> ."
4. Power on the switches.	N/A
5. Configure basic IRF settings.	See <i>H3C S6805 &amp; S6825 &amp; S6850 &amp; S9850 Switch Series Virtual Technologies Configuration Guide</i> .
6. Connect the physical IRF ports.	Connect the physical IRF ports on switches. Use QSFP28/QSFP+ transceiver modules and fibers for connections over long distances. Use QSFP28/QSFP+ cables for connections over short distances. All switches except the master switch automatically reboot, and the IRF fabric is established.

## Planning IRF fabric setup

This section describes issues that an IRF fabric setup plan must cover.

### Planning IRF fabric size and the installation site

Determine the number of required IRF member switches, depending on the user density and upstream bandwidth requirements. The switching capacity of an IRF fabric equals the total switching capacities of all member switches.

You can use switches of the same series or use switches of both the S6850 and S9850 series to form an IRF fabric.

Plan the installation site depending on your network solution as follows:

- Place all IRF member switches in one rack for centralized high-density access.
- Distribute the IRF member switches in different racks to implement the top-of-rack (ToR) access solution for a data center.

As your business grows, you can add member switches into the IRF fabric to increase the switching capacity without any topology change or replacement.

### Identifying the master switch and planning IRF member IDs

Determine which switch you want to use as the master for managing all member switches in the IRF fabric. An IRF fabric has only one master switch. You configure and manage all member switches in the IRF fabric at the command line interface of the master switch.

---

#### NOTE:

IRF member switches will automatically elect a master. You can affect the election result by assigning a high member priority to the intended master switch. For more information about master election, see *H3C S6805 & S6825 & S6850 & S9850 Switch Series Virtual Technologies Configuration Guide*.

---

Prepare an IRF member ID assignment scheme. An IRF fabric uses member IDs to uniquely identify and manage its members, and you must assign each IRF member switch a unique member ID.

# Planning IRF topology and connections

You can create an IRF fabric in daisy chain topology, or more reliably, ring topology. In ring topology, the failure of one IRF link does not cause the IRF fabric to split as in daisy chain topology. Rather, the IRF fabric changes to a daisy chain topology without interrupting network services.

You connect the IRF member switches through IRF ports, the logical interfaces for the connections between IRF member switches. Each IRF member switch has two IRF ports: IRF-port 1 and IRF-port 2. To use an IRF port, you must bind a minimum of one physical port to it.

When connecting two neighboring IRF member switches, you must connect the physical ports of IRF-port 1 on one switch to the physical ports of IRF-port 2 on the other switch.

The IRF port connections in the two figures are for illustration only, and more connection methods are available.

**Figure4-2 IRF fabric in daisy chain topology**

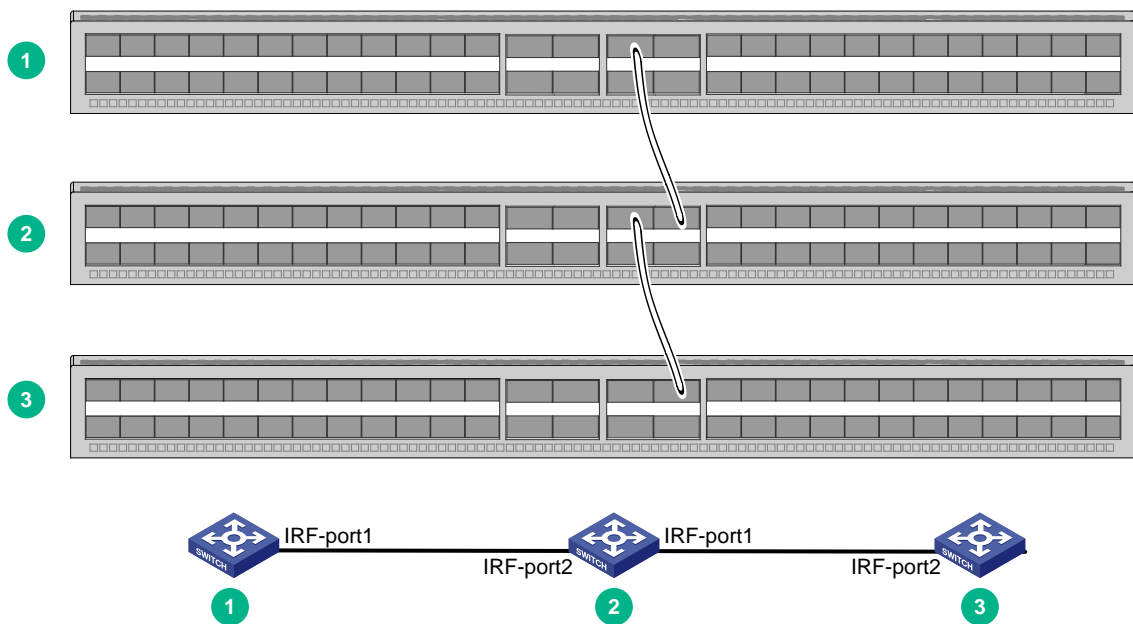
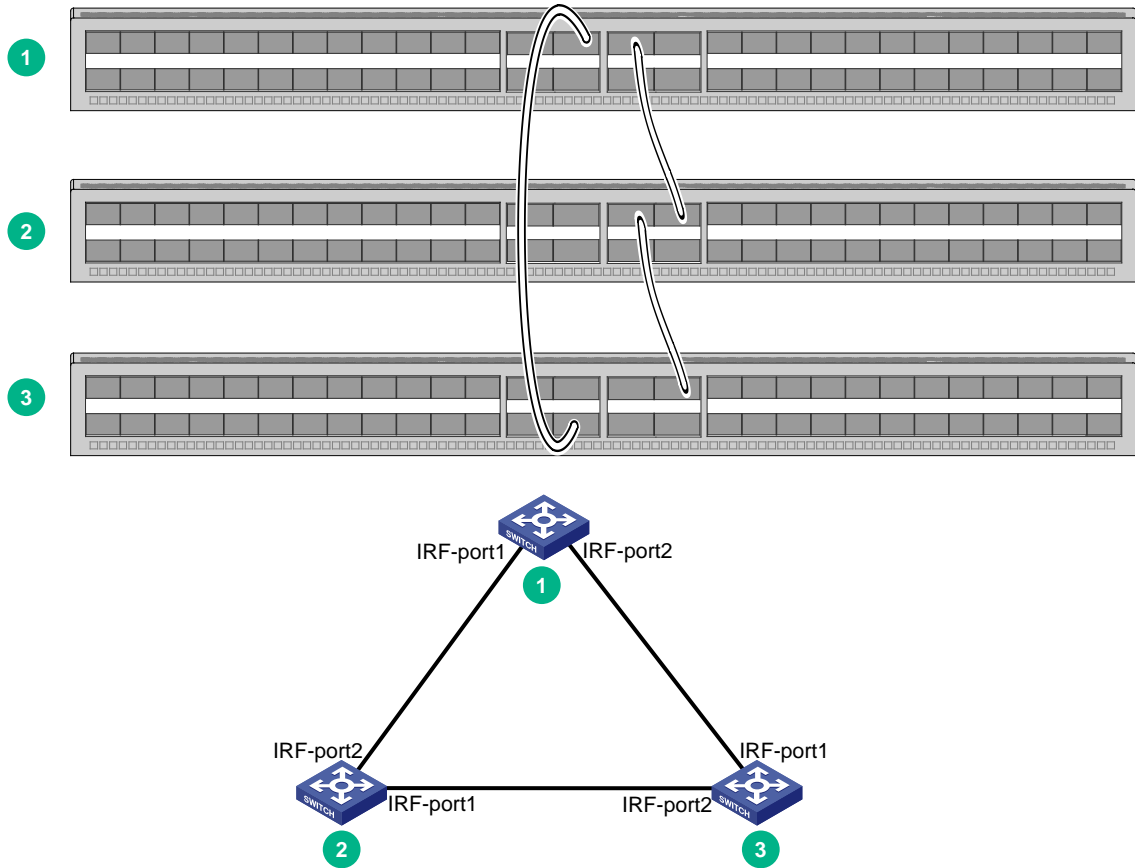



Figure4-3 IRF fabric in ring topology



You can set up IRF links between S6850/S9850 switches as follows:

- Use a QSFP28 module and fiber or a QSFP28 cable to connect QSFP28 ports for a 100-GE IRF physical connection.
- Use a QSFP+ module and fiber or a QSFP+ cable to connect QSFP28 ports for a 40-GE IRF physical connection.
- Use a QSFP+ module and fiber or a QSFP+ cable to connect QSFP+ ports for a 40-GE IRF physical connection.

You can bind several ports to an IRF port for increased bandwidth and availability.

When you use a QSFP+ DAC cable to connect a pair of peer IRF physical interfaces on S6850 or S9850 switch series, follow these restrictions and guidelines:

- The peer interfaces must both be fixed ports or both be ports on expansion interface modules that are the same model.
- If one interface is a fixed QSFP28 port on the rear panel of an S6850-2C switch, the other interface must also be a fixed QSFP28 port on the rear panel of an S6850-2C switch.

## Identifying physical IRF ports on the member switches

Identify the physical ports for IRF connections on the member switches according to your topology and connection scheme.

All the QSFP28 ports and QSFP+ ports on the switches (including those on the interface modules), can be used for IRF connections, except for QSFP28 ports on LSWM18CQMSEC interface modules.

When you select ports in a port group for IRF links, you must use all or none of the ports in the group for IRF links. The ports can be bound to different IRF ports.

On an LSWM116Q interface module of the switches, odd and even numbered ports are separated for grouping. The ports are grouped by port number in order, starting from the lowest odd or even number. Each group contains two ports with consecutive odd or even port numbers.

## Planning the cabling scheme

You can use QSFP28/QSFP+ cables, or QSFP28/QSFP+ transceiver modules and fibers to connect the S6850/S9850 switches for IRF connections.

If the switches are all in one equipment room, choose QSFP28/QSFP+ cables for IRF connections. If the switches are far away from one another, choose QSFP28/QSFP+ transceiver modules and fibers for IRF connections.

For more information about available cables, see *H3C S6850 & S9850 Switch Series Hardware Information and Specifications*.

The following subsections describe several IRF connection schemes by using the QSFP28 cables and QSFP28 transceiver modules and fibers. As a best practice, use the ring topology for IRF connections.

### Connecting the IRF member switches in one rack

Figure4-4 shows an example for connecting four IRF member switches in a rack. The switches in the ring topology (see Figure4-5) are in the same order as connected in the rack.

**Figure4-4 Connecting the switches in one rack**

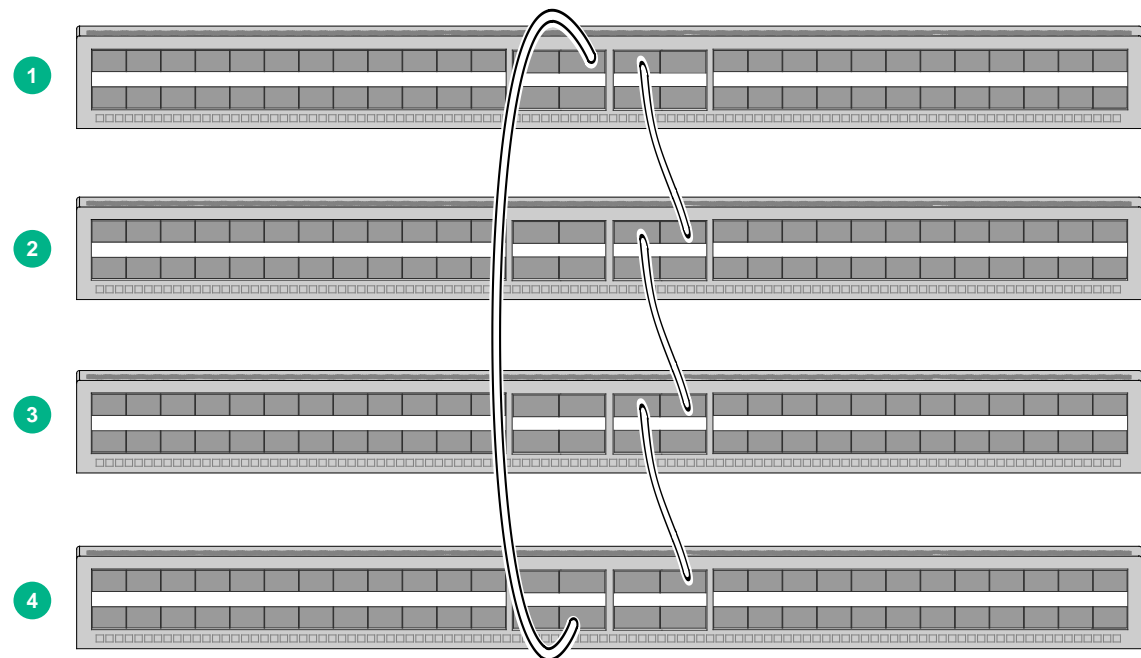
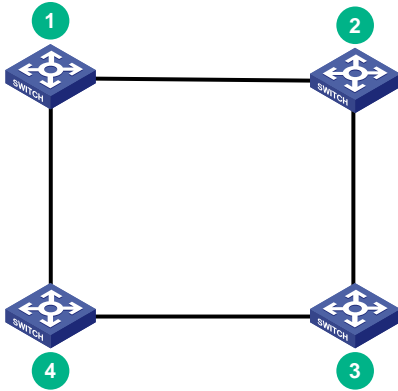

Figure4-5 IRF fabric topology



### Connecting the IRF member switches in a ToR solution

You can install IRF member switches in different racks side by side to deploy a top of rack (ToR) solution.

Figure4-6 shows an example for connecting four top of rack IRF member switches. The topology is the same as Figure4-5.

Figure4-6 ToR cabling

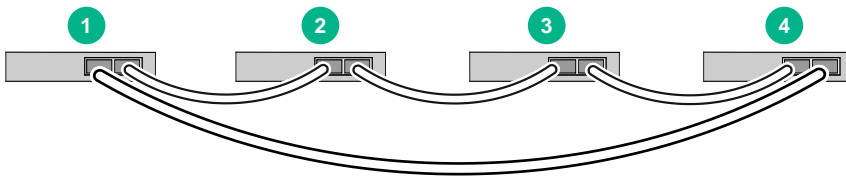

## Configuring basic IRF settings

After you install the IRF member switches, power on the switches, and log in to each IRF member switch (see *H3C S6805 & S6825 & S6850 & S9850 Switch Series Fundamentals Configuration Guide*) to configure their member IDs, member priorities, and IRF port bindings.

Follow these guidelines when you configure the switches:

- Assign the master switch higher member priority than any other switch.
- Bind physical ports to IRF port 1 on one switch and to IRF port 2 on the other switch. You perform IRF port binding before or after connecting IRF physical ports depending on the software release.
- Execute the `display irf configuration` command to verify the basic IRF settings.

For more information about configuring basic IRF settings, see *H3C S6805 & S6825 & S6850 & S9850 Switch Series Virtual Technologies Configuration Guide*.

## Connecting the physical IRF ports

### ⚠ CAUTION:

Wear an ESD wrist strap when you install transceiver modules, fibers, and cables. For more information, see the installation guide.

Use transceiver modules and fibers or cables to connect the IRF member switches as planned.

# Accessing the IRF fabric to verify the configuration

To verify the basic functionality of the IRF fabric after you finish configuring basic IRF settings and connecting IRF ports:

1. Log in to the IRF fabric through the console port of any member switch.
2. Create a Layer 3 interface, assign it an IP address, and make sure the IRF fabric and the remote network management station can reach each other.
3. Use Telnet or SNMP to access the IRF fabric from the network management station. (See *H3C S6805 & S6825 & S6850 & S9850 Switch Series Fundamentals Configuration Guide*.)
4. Verify that you can manage all member switches as if they were one node.
5. Display the running status of the IRF fabric by using the commands in [Table4-1](#).

**Table4-1 Displaying and maintaining IRF configuration and running status**

Task	Command
Display information about the IRF fabric.	<code>display irf</code>
Display all members' IRF configurations.	<code>display irf configuration</code>
Display IRF fabric topology information.	<code>display irf topology</code>

**NOTE:**

To avoid IP address collision and network problems, configure at least one multi-active detection (MAD) mechanism to detect the presence of multiple identical IRF fabrics and handle collisions. For more information about MAD detection, see *H3C S6805 & S6825 & S6850 & S9850 Switch Series Virtual Technologies Configuration Guide*.

# 5 Maintenance and troubleshooting

## Power module failure

### Symptom

The power module status LED on a power module is not steady green.

For more information about the LEDs on a power module, see *H3C LSVM1AC650 & LSVM1DC650 Power Modules User Manual*.

### Solution

To resolve the issue:

1. Verify that the power cord is connected correctly.
2. Verify that the power source is as required by the switch.
3. Verify that the operating temperature of the switch is in the acceptable range and the power module has good ventilation.
4. If the issue persists, contact H3C Support.

To replace a power module, see "[Installing/removing power modules](#)."

## Fan tray failure

---

### △ CAUTION:

The S6850-56HF, S6850-2C, and S9850-32H switches each have five fan tray slots. The S9850-4C switch has two fan tray slots. To replace failed fan trays on an operating switch, follow these guidelines:

- If multiple fan trays fail on an operating S6850-56HF, S6850-2C, or S9850-32H switch, do not remove the fan trays at the same time. Replace the fan trays one after another and finish replacing a fan tray within 3 minutes.
  - If a fan tray fails on an operating S9850-4C switch, replace the fan tray immediately and keep the failed fan tray in position before replacement. If two fan trays fail, finish replacing the fan trays within 1 minute.
- 

### Symptom

- The status LED on an LSWM1FANSA, LSWM1FANSA-SN, LSWM1FANSAB, or LSWM1FANSAB-SN fan tray is steady orange and the system outputs alarm messages.
- The status LED on an LSWM1BFANSC, LSWM1BFANSC-SN, LSWM1BFANSCB, or LSWM1BFANSCB-SN fan tray is steady yellow and the system outputs alarm messages.

### Solution

See "[Installing/removing fan trays](#)" to replace the fan tray. If the problem persists, contact H3C Support.

# Configuration terminal display problems

## No display

### Symptom

The configuration terminal displays nothing when the switch is powered on.

### Solution

To resolve the issue:

1. Verify that the power system is operating correctly.
2. Verify that the console cable is connected correctly.
3. Verify that the console cable does not have any problems and the terminal settings are correct.
4. If the issue persists, contact H3C Support.

## Garbled display

### Symptom

The configuration terminal has a garbled display.

### Solution

To resolve the issue:

1. Verify that the following settings are configured for the terminal:
  - **Baud rate**—9,600.
  - **Data bits**—8.
  - **Parity**—None.
  - **Stop bits**—1.
  - **Flow control**—None.
2. If the issue persists, contact H3C Support.