

# DHI-ITC952-AU3F-LZF1640

9MP All-in-one AI Enforcement Camera



- GS-CMOS image sensor.
- 4096 × 2824@50 fps.
- Video compression standards: H.265, H.264M, H.264H and MJPEG.
- Integrated design, IP66 and IK10 rated.
- Under recommended installation and lighting conditions:
  - Capture rate > 99%
  - LPR accuracy > 98%

## System Overview

With its high-performance AI processor, 9MP All-in-one AI Enforcement Camera delivers high quality images even in the toughest weather conditions. For monitoring, it uses deep learning algorithms and GS-CMOS image sensors with a wide dynamic range and a high frame rate, making it ideal for traffic scenarios. With its advanced image technology, the white light supplements light at night to allow the camera to take vivid, full color images without using the external flashing light or strobe.

## Functions

### Reduced light pollution

The illuminators supplement light when the camera captures license plates without using the external flashing light or strobe, significantly reducing light pollution.

### Ultra-high frame rate

Uses traffic-specific, high-performance GS-CMOS image sensors with a wide dynamic range, high frame rate, and high signal-to-noise ratio, displaying realistic video images in the day and night.

### Video metadata

Deep learning algorithms and a high-performance AI processor allow the camera to detect and extract detailed information on motor vehicles, providing a reliable data source that can be used in making effective decisions.

### Applicable to various road scenes

Ideal for scenarios where license plate recognition is needed, the camera is capable of capturing more than ten different types of traffic violations, and supports traffic information collection and event detection.

### Multi-dimensional data sensing

Using GPS positioning, the camera realizes multi-dimensional data sensing.

## Safe and reliable performance

Built to withstand the toughest conditions, this camera functions in a wide temperature and voltage range. It has a built-in lightning protection module, is IP66 and IK10 rated. Feel safe using it in all-weather types.

## Scene

The camera is ideal for use in intelligent traffic management and for smart city businesses. It is capable of detecting traffic violations, capturing license plates, generating passing vehicle records, collecting traffic data, and detecting events.

## Technical Specification

### Camera

Image Sensor	1.1" GS-CMOS
Shutter Mode	Single shutter; Double shutter; Three shutters
Electronic Shutter Speed	Auto/Manual 1/50 s–1/100,000 s
Noise Reduction	3D NR
S/N	48 dB
WDR	120 dB
Minimum intensity	0.001 lux
Day/Night	Supports ICR auto switch: IR cut-off filter (IRCF) with the polarizing filter is used during the daytime, and switches to the common IR cut-off filter at night

### Illuminator

Illuminator Number	6
Illumination Distance	23 m–30 m (75.46 ft–98.43 ft) (adjustable brightness)
Covered lane	3 lanes

Lens	
Lens Type	Motorized vari-focal
Focal Length	16 mm–40 mm
Max. Aperture	F1.5
Aperture Type	P iris
Field of View	Horizontal: 21.2°–50.1° Vertical: 14.7°–34.4° Diagonal: 25.3°–60.3°

Function	
Trigger Mode	Video detection; radar
Speed Detection Range	0 km/h–300 km/h
OSD Overlay	Time, address, lane No., plate, plate color, and more
Alarm Event	Storage full, storage error, external alarm, no storage card, license plate blocklist, illegal access, network disconnection, and IP conflict
Automatic Network Replenishment (ANR)	Platform and FTP (TF card is required)
Auto Registration	Yes

Intelligence	
Target Detection	Motor vehicle; motorcycle
Face Detection	Detects the driver and front-seat passenger of motor vehicles, and motorcycle drivers; extracts face images
ANPR	Adopts developed algorithms to recognize license plate numbers and letters
Vehicle Type Recognition	Vehicle head: SUV, large bus, sedan, light truck, pickup, heavy truck, medium truck, van, medium bus, MPV Vehicle tail: SUV, large bus, sedan, light truck, pickup, heavy truck, medium truck, van
Vehicle Color Recognition	White, pink, black, red, yellow, gray, blue, green, orange, purple, brown, and silver gray
Accuracy (Under recommended installation and lighting conditions)	Capture rate > 99%; LPR accuracy > 98%
Vehicle logo	Vehicle head mode: Acura, Alfaromeo, Ashokleyland, Astonmartin, Audi, Baic, Bently, Benz, BMW, Buick, BYD, Cadillac, Chery, Chevrolet, Chrysler, Citroen, Dacia, Daihatsu, Datsun, Dodge, DS, Ferrari, Fiat, Force, Ford, Foton, Geely, GMC, Greatwall, Hino, Honda, Hyundai, Infiniti, Isuzu, Iveco, Jac, Jaguar, Jeep, Kia, Kinglong, Land, Lexus, Lifan, Lincoln, Mahindra, MAN, Maserati, Mazda, Mercury, MG, Mini, Mitsubishi, Nissan, Opel, Peugeot, Porsche, Renault, Rollsroyce, Saab, Scania, Seat, Skoda, Smart, Subaru, Suzuki, Tata, Tesla, Toyota, UD, Volkswagen, Volvo
Motor Vehicle Violation Snapshot	ANPR mode: Wrong-way driving, speeding, driving slow, crossing the solid white line, crossing the solid yellow line, illegal lane change, unfasten seat belt, calling while driving, smoking while driving E-Police mode: Running a red light, wrong-way driving, crossing the solid white line, crossing the solid yellow line, disobeying the lane direction sign, disobeying the direction arrow, illegal left turn, illegal right turn, illegal U-turn (not supported by side-mounted cameras), and crossing the stop line
Motorcycle vehicle Violation Capture	Captures traffic violations including carrying passenger, not wearing helmet, and wrong-way driving

Traffic Flow Detection	Generates statistics on vehicle flow, queue length, average speed, lane occupancy, and more
Traffic Event	Motor vehicle illegal stopping on the roadway, traffic congestion

## Video

Video Compression	H.265; H.264M; H.264H; MJPEG
Video Resolution	4096 × 2824; QFHD (3840 × 2160); 1080p (1920 × 1080); UXGA (1600 × 1200); 720p (1280 × 720)
Video Frame Rate	50 Hz: Maximum 50 fps; default main stream (4096 × 2824@25 fps), sub stream (1600 × 1200@25 fps) 60 Hz: Maximum 30 fps; default main stream (4096 × 2824@15 fps), sub stream (1600 × 1200@15 fps)
Video Bit Rate	H.264: 32 kbps–32767 kbps H.265: 32 kbps–32767 kbps MJPEG: 512 kbps–32767 kbps
Bit Rate Control	CBR; VBR
White Balance	Auto; night; custom color temperature
Edge Enhancement	Yes
HLC	Yes
BLC	Yes
Bad Pixel Correction	Yes
Gain Scope	0–100

## image

Composite Image	Supports combining up to 4 images into a composite image
Image Resolution	4096 (H) × 2824 (V) (OSD black background is not calculated in the pixels)
Image Encoding Format	JPEG
Image Tampering Prevention	Watermark and verification are available for videos and images

## Network

Network Port	2 RJ-45 Ethernet ports, 10/100/1000 M network transmission
SDK and API	Yes
Security	Authorized username and password, MAC address binding, HTTPS encryption, and network access control
Protocol	IPv4; IPv6; HTTP; TCP; IP; UDP; NTP; DHCP
Interoperability	ONVIF (Profile S/Profile G/Profile T)
Browser	Microsoft Edge IE: IE9–IE11 Chrome: Chrome 41 and earlier Firefox: Firefox 49 and earlier For Win 10 users, run the browser as administrator
Positioning	GPS
Time Synchronization	NTP; GPS

## Port

Storage	1, supports maximum 256 GB TF card local storage
Iris Control	1, connects to DC iris or P iris
Focus Control	1, connects to motorized vari-focal lens
Frequency Source Sync	1, supports synchronizing the camera with the mains electricity

Peripheral Light	7, optocoupler signal output (can be configured as flashing light or LED strobe sync output port, frequency adjustable)
USB	2 USB 2.0 ports
RS-485	2, connects to devices such as signal detector, radar, and more
RS-232	4 (1 is used for serial debugging and 3 for connecting to radars)
I/O	4, same functions as ALARM IN port
Audio Input	1, 3.5 mm (0.14") jack
Audio output	1, 3.5 mm (0.14") jack
Alarm Input	4, same functions as I/O port
Alarm Output	2 (AO1 is for relay output and AO2 for optocoupler output)
Power Output	12 VDC ±10% voltage output, ≤ 1.5 A current output

**General**

Power Supply	100–240 VAC, 50 Hz/60 Hz
Power Consumption	≤ 20 W
Operating Temperature	–40 °C to +65 °C (–40 °F to +149 °F)
Storage Temperature	–40 °C to +70 °C (–40 °F to +154 °F)
Operating Humidity	10%-90% (RH)
Storage Humidity	0%-90% (RH)
Protection	IP66, IK10
Certifications	CE: 4789630630-1, FCC: 4789630630-2
Product Dimensions	554.0 mm × 204.2 mm × 209.6 mm (21.81" × 8.04" × 8.25") (L × W × H)
Net Weight	4.6 kg (10.14 lb)
Gross Weight	6.6 kg (14.55 lb)
Installation	Center mount; Side mount

**Ordering Information**

Type	Model	Description
AI Enforcement Camera	DHI-ITC952-AU3F-LZF1640	9MP all-in-one AI enforcement camera
Accessories (Optional)	8019	3-dimensional universal mounting bracket (purchase separately)
	3012	Side Mounting Bracket (purchase separately)
	PFA150	Mounting Bracket (purchase separately)

**Accessories**

Optional:

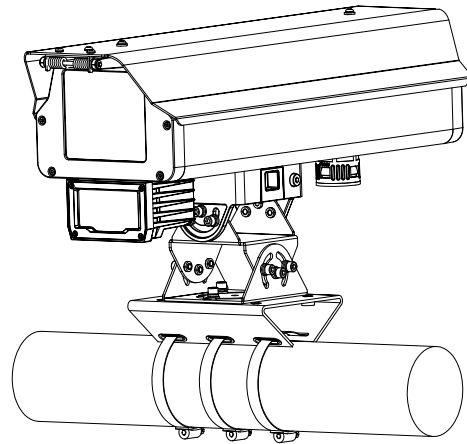
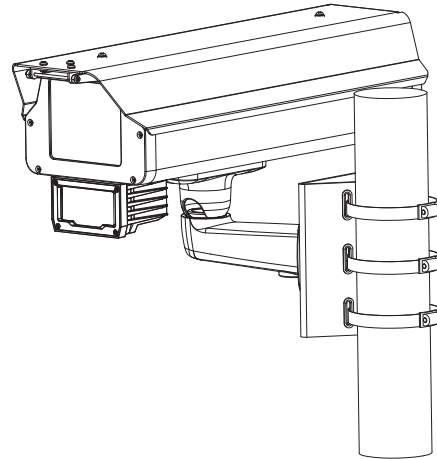

**Dimensions (mm [inch])**

