

# DH-HAC-HDW1200TMQ-A-POC

## 2MP HDCVI POC Fixed IR Quick-to-install Eyeball Camera



\* The parameters and datasheets below can only be applied to 1200-55-POC series.

- Max 30 fps@1080P.
- Quick-to-install eyeball saves installation time.
- 3.6mm fixed lens (2.8mm,6mm optional).
- CVI/CVBS/AHD/TVI switchable.
- Built-in mic.
- Max. IR length 60m, Smart IR.
- IP67, PoC (only CVI)/12V±30% DC.



### Series Overview

Built for convenience, the PoC Series features highly reliable cameras that are powered directly by recorders on the same coaxial cable\* that its videos are transmitted over. HDCVI PoC technology greatly reduces material and installation cost, making it an ideal choice for customers who are on a tight budget and are working with scenes that require complex deployment.

\*We recommend choosing RG59 or RG6 cable for PoC transmission.

### Functions

#### 4 Signals over 1 Coaxial Cable

HDCVI technology supports 4 signals to be transmitted over 1 coaxial cable simultaneously, i.e. video, audio\*, data and power. Dual-way data transmission allows the HDCVI camera to interact with the XVR, such as sending control signal or triggering alarm. Moreover, HDCVI technology supports PoC for construction flexibility.

\* Audio input is available for some models of HDCVI cameras.

#### Long Distance Transmission

HDCVI technology guarantees real-time transmission at long distance without any loss. It supports up to 700m transmission for 2MP/5MP/8MP HD video via coaxial cable, and up to 300m via UTP cable.

\*Actual results verified by real-scene testing in Dahua's test laboratory.

#### Simplicity

HDCVI technology inherits the born feature of simplicity from traditional analog surveillance system, making itself a best choice for investment protection. HDCVI system can seamlessly upgrade the traditional analog system without replacing existing coaxial cabling. The plug and play approach enables high definition video surveillance without the hassle of configuring a network.

### Smart Illumination

The camera is designed with IR illumination for best lowlight performance. Smart IR is a technology to ensure brightness uniformity in B/W image under low illumination. Dahua's unique Smart IR adjusts to the intensity of camera's infrared LEDs to compensate for the distance of an object, and prevents IR LEDs from overexposing images as the object come closer to the camera.

### Easy Installation

HDCVI quick-to-install eyeball adopts quick-to-install pedestal, which can achieve easier installation than conventional eyeball. Quick-to-install camera reduces time and labor costs.

### Broadcast-quality Audio

Audio information is used as supplementary evidence in video surveillance applications. The HDCVI camera supports audio signal transmission over coaxial cable. In addition, it adopts unique audio processing and transmission technology that best restores source audio and eliminates noise, guaranteeing the quality and effectiveness of collected audio information.

### Protection (IP67, wide voltage)

IP67: The camera passes a series of strict test on dust and soak. It has dust-proof function, and the enclosure can works normal after soaking in 1 m deep water for 30 minutes.

Wide voltage: The camera allows ±30% (for some power supplies) input voltage tolerance (wide voltage range), and it is widely applied to outdoor environment with instable voltage.

**Technical Specification**

<b>Camera</b>	
Image Sensor	2MP CMOS
Max. Resolution	1920 (H) × 1080 (V)
Pixel	2MP
Scanning System	Progressive
Electronic Shutter Speed	PAL: 1/25 s–1/100,000 s NTSC: 1/30 s–1/100,000 s
S/N Ratio	> 65 dB
Min. Illumination	0.02 Lux/F1.9, 30 IRE, 0 Lux IR on
Illumination Distance	60 m (196.9 ft)
Illuminator On/Off Control	Auto; manual
Illuminator Number	2 (IR light)
Pan/Tilt/Rotation Range	Pan: 0°–360° Tilt: 0°–78° Rotation: 0°–360°

<b>Lens</b>	
Lens Type	Fixed lens
Mount Type	M12
Focal Length	2.8 mm; 3.6 mm; 6 mm
Max. Aperture	F1.9
Field of View	2.8 mm: D: 119°, H: 101°, V: 54° 3.6 mm: D: 100°, H: 84°, V: 45° 6 mm: D: 60°, H: 56°, V: 30°
Iris Type	Fixed iris
Close Focus Distance	2.8 mm: 0.5 m (1.6 ft) 3.6 mm: 0.8 m (2.6 ft) 6 mm: 2 m (6.6 ft)
DORI Distance	2.8 mm: D: 38.6 m (126.6 ft); O: 15.4 m (50.5 ft); R: 7.7 m (25.3 ft); I: 3.9 m (12.8 ft) 3.6 mm: D: 49.7 m (163.1 ft); O: 19.9 m (65.3 ft); R: 9.9 m (32.5 ft); I: 5 m (16.4 ft) 6 mm: D: 82.8 m (271.7 ft); O: 33.1 m (108.6 ft); R: 16.6 m (54.5 ft); I: 8.3 m (27.2 ft)

<b>Video</b>	
Frame Rate	CVI: 1080p@25/30 fps; 720p@25/30 fps; AHD: 1080p@25/30 fps; 720p@25/30 fps; TVI: 1080p@25/30 fps; 720p@25/30 fps; CVBS: 960H
Resolution	1080p (1920 × 1080); 720p (1280 × 720); 960H (960 × 576/960 × 480)
Day/Night	Auto switch by ICR
BLC	BLC/DWDR/HLC
White Balance	Auto/Area WB
Gain Control	Auto; manual

Noise Reduction	2D NR
Smart IR	Yes
Mirror	Off/On
Privacy Masking	Off/On (8 area, rectangle)

<b>Certifications</b>	
Certifications	CE (EN55032, EN55024, EN50130-4) FCC (CFR 47 FCC Part 15 subpartB, ANSI C63.4-2014) UL (UL60950-1+CAN/CSA C22.2 No.60950-1)

<b>Port</b>	
Video Output	Video output choices of CVI/TVI/AHD/CVBS by one BNC port
Audio Input	One channel built-in mic

<b>Power</b>	
Power Supply	POC (only CVI)/12V±30% DC
Power Consumption	Max 4.9W (12 VDC, IR on); POC (AF)

<b>Environment</b>	
Operating Temperature	–40 °C to +60 °C (–40 °F to 140 °F); < 95% (non-condensation)
Storage Temperature	–40 °C to +60 °C (–40 °F to 140 °F); < 95% (non-condensation)
Protection Grade	IP67

<b>Structure</b>	
Casing	Metal dome+metal cover+plastic decorative ring
Camera Dimensions	φ121.9 mm × 99.1 mm (φ4.8" × 3.9")
Net Weight	0.42 Kg (0.9 lb)
Gross Weight	0.62 Kg (1.4 lb)

Ordering Information		
Type	Model	Description
2MP Camera	DH-HAC-HDW1200TMQP-A-POC	2MP HDCVI POC Fixed IR Quick-to-install Eyeball Camera, PAL
	DH-HAC-HDW1200TMQN-A-POC	2MP HDCVI POC Fixed IR Quick-to-install Eyeball Camera, NTSC
Accessories (Optional)	PFA130-E	Water-proof Junction Box
	PFB205W	Wall Mount Bracket
	PFA152-E	Pole Mount Bracket
	PFB220C	Ceiling Mount Bracket of Mini Dome & Eyeball Camera
	PFA109	Mount Adapter
	PFM321D	12V 1A Power Adapter
	PFM904	Integrated Mount Tester

Dimensions (mm[inch])

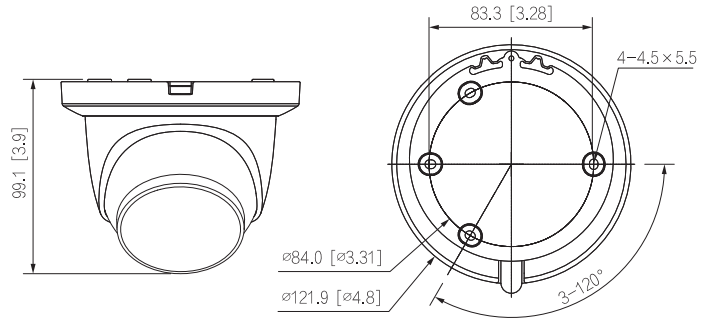

Accessories

Optional:



PFA130-E  
Water-proof Junction Box



PFB205W  
Wall Mount Bracket



PFA152-E  
Pole Mount Bracket



PFB220C  
Ceiling Mount Bracket  
of Mini Dome & Eyeball  
Camera



PFA109  
Mount Adapter



PFM321D  
12V 1A Power Adapter



PFM904  
Integrated Mount Tester

Junction Mount	Wall Mount	Pole Mount (Vertical)